

H5U Application Guidance

V1.0_Nov 5, 2021_PMTS



Contents

H5U Products

- [Features Overview](#)
- [Hardware Configuration](#)
- [Hardware Interface](#)
- [Typical Topology](#)

Autoshop Software

- [Download and Installation](#)
- [Create Project](#)
- [UI introduction](#)
- [Project Basic Setting](#)
- [Module Configuration](#)
- [Motion Control Axis Configuration](#)
- [EtherCAT Configuration](#)
- [Trace Function](#)
- [Connection with PLC](#)
- [Programming](#)
- [Download/Upload](#)
- [Download File](#)
- [Pack Project Archives](#)
- [Firmware Upgrade](#)

Data and Memory

- [Memory Assignment](#)
- [Soft Element](#)
- [Special Soft Element](#)
- [System Variable](#)
- [User Defined Variable](#)

Instructions

- [Instructions](#)
- [Program Logic](#)
- [Flow Control](#)
- [Contact Load](#)
- [Data Computation](#)
- [Data Processing](#)
- [Matrix](#)
- [String Processing](#)
- [Clock](#)
- [Timer](#)
- [Pointer](#)
- [Communication-Serial](#)
- [Communication-Socket](#)
- [PID](#)
- [Basic Motion Control](#)
- [CAM](#)
- [Interpolation](#)
- [Motion Control\(CANopen\)](#)
- [High Speed Input](#)

Features

- [IT7000&H5U Simulation](#)
- [Online Modification](#)
- [FB/FC](#)
- [Sub Program](#)

H5U Error Code

- [H5U Error Code](#)

Application Example

- [Application Example](#)

H5U Products

- Function Block + Library Encapsulation(FB/FC)
- User Defined Variable
- High Speed IO
- Socket Communication
- FBD + LD Programming
- CAM + Interpolation Motion

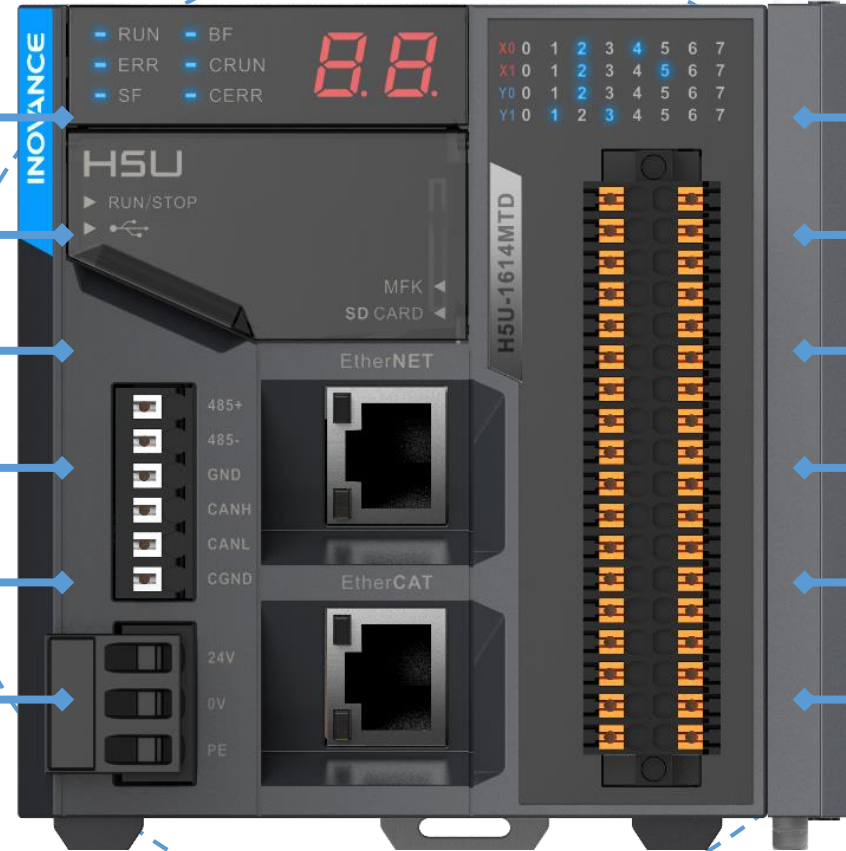

EtherCAT[®]
Technology Group

CANlink

CANopen

RS485

Modbus TCP



H5U Series **EtherCAT High Performance Small Size PLC**

Hardware Configuration

H5U	Specifications
Storage	200K program storage, 2MByte custom variable storage
Axes	EtherCAT: 32 axes Local Pulse: 4 axes
Serial port	1 x RS485
CAN port	CANlink, CANopen
Fast input	4 channel 200K
Fast output	4 channel 200K
Extension modules	16 Up to 72 EtherCAT stations (including Servos)
Program Language	LD, SFC, supports FB/FC (LD)
Ethernet	Modbus TCP, Socket, program upload/download Supports EtherCAT
USB、SD card	Program upload/download and firmware upgrade (only SD card)
Structure	Compact and small size: 83 x 90 x 95 (mm)

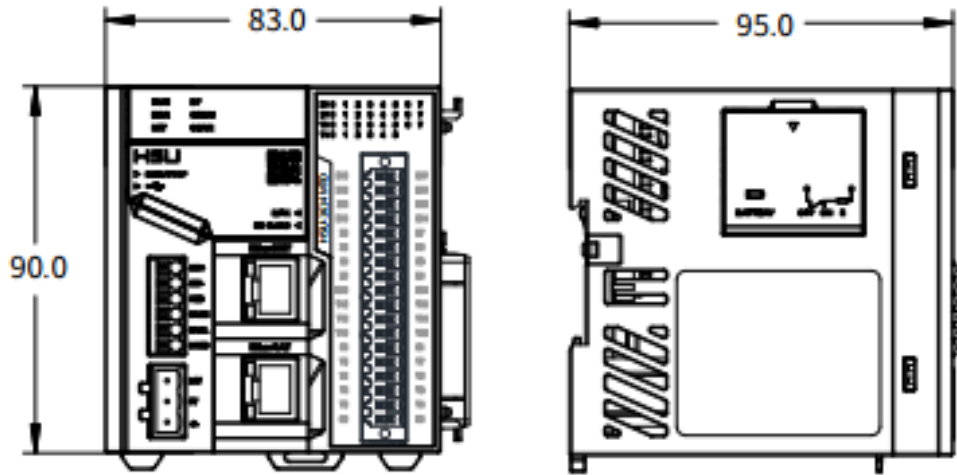

Hardware Interface

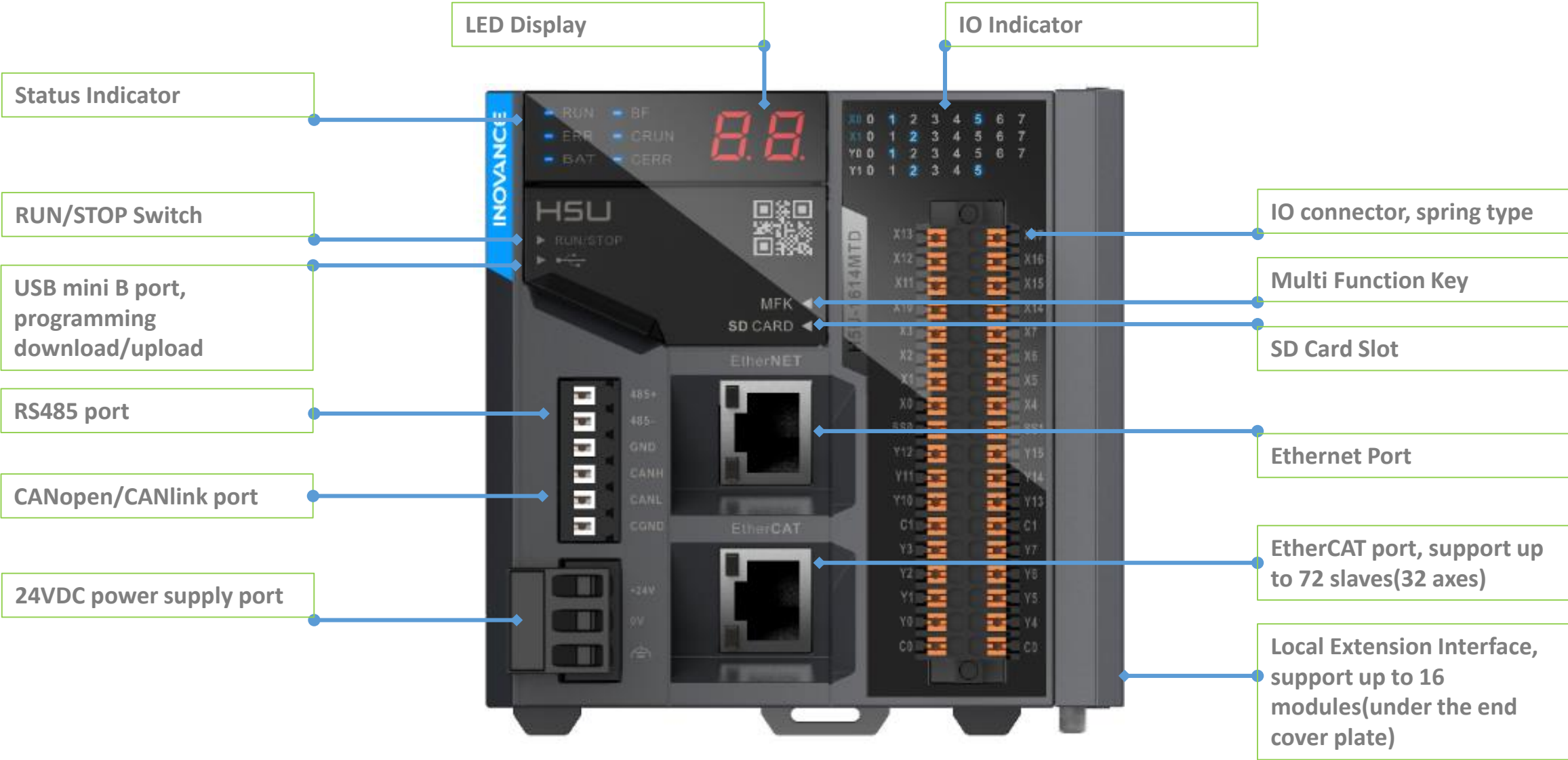

Typical Topology

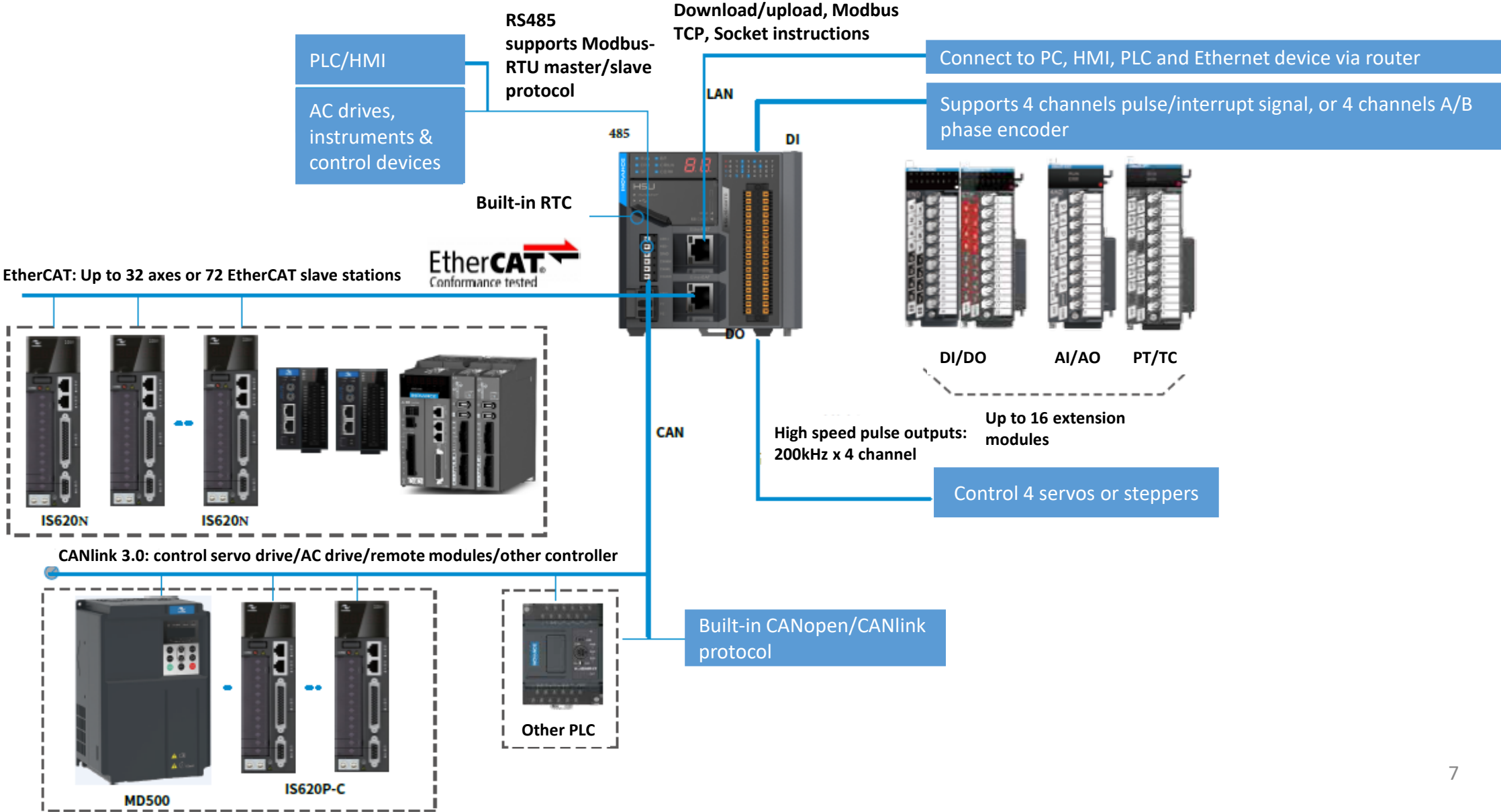

Available Models

Model	Part No.	Description	CE
H5U-1614MTD	01440087	Programmable Logic Controller-H5U-1614MTD-H5U Series 16 Input 14 Output Programmable Logic Controller	Yes
H5U-1614MTD-A16	01440235	Programmable Logic Controller-H5U-1614MTD-A16-H5U Series 16 Input 14 Output Programmable Logic Controller(16 axis)	Yes
H5U-1614MTD-A8	01440236	Programmable Logic Controller-H5U-1614MTD-A8-H5U Series 16 Input 14 Output Programmable Logic Controller(8 axis)	Yes
H5U-1614MTD-A8S	01440315	Programmable Logic Controller-H5U-1614MTD-A8S-H5U Series 16 Input 14 Output Programmable Logic Controller(8 axis without CAN and CAM function)	Yes

AutoShop Software

Download and Installation

[Back to Contents](#)

Download software(V4.2.0.0 or above) from website: <https://www.inovance.com/hc/allResult?key=Autoshop>, or contact local inovance representative to get the latest software.

After download the software, click the Autoshop V**** startup.exe file to install the software.

 AutoShop V4.2.0.0 Setup.exe

Create Project

Click the icon  to open AutoShop software, then select <File>→<New Project>

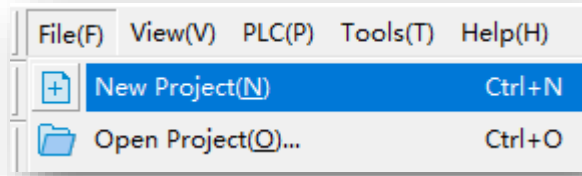

Set project name and save path according real demand, select <H5U Series> IN <Series and models>, then click <OK> button, a new project will be created.

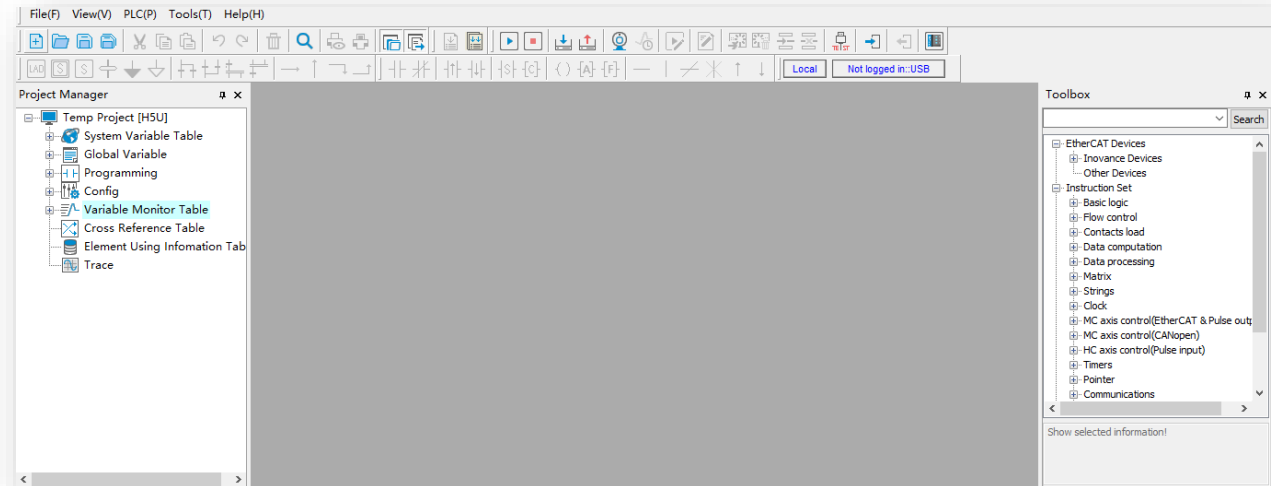
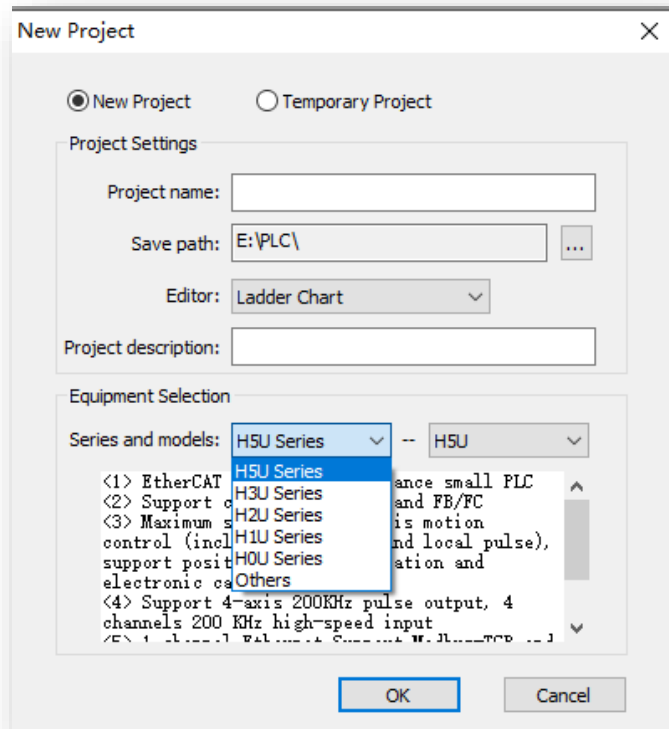

The screenshot displays the Inovance software interface with several key components highlighted:

- Menu bar:** Located at the top, containing menus for File(F), Edit(E), View(V), Ladder Chart(L), PLC(P), Debug(D), Tools(T), Window(W), and Help(H).
- Fast tool bar:** A toolbar below the menu bar with various icons for file operations, editing, and execution. It also includes status indicators for 'Local' and 'Not logged in::USB'.
- Project Manager View:** A tree view on the left side showing the project structure for 'H5U_IT7000 [H5U]'. It includes categories like System Variable Table, Global Variable, Programming (highlighted), Config, Variable Monitor Table, Cross Reference Table, Element Using Information Table, and Trace.
- Program Edit Area:** The central workspace showing a ladder logic network. It features:
 - Net 1:** Contains three methods:
 - method 1: modify CAM keypoint (be noted CanNode = Null)
 - method 2: modify CAM points (be noted CanNode = Null)
 - method 3: create a new CAM nodes array, then copy all points to current CAM (be noted CanNode <> Null)
 - MC_GenerateCamTable:** A function block with inputs: CamTable, CamNode, NodeNum, Mode. Outputs: Done, EndPointIndex, ErrorNodePointIndex, Busy, CommandAborted, Error, ErrorID.
 - MC_GetCamTablePhase:** A function block with inputs: CamTable, StartPoint. Outputs: Done, Number, Phase.
- Toolbox:** A panel on the right side containing a search bar and a list of components categorized under EtherCAT Devices, Instruction Set, FB, FC, and Library.

➤ Project Manager

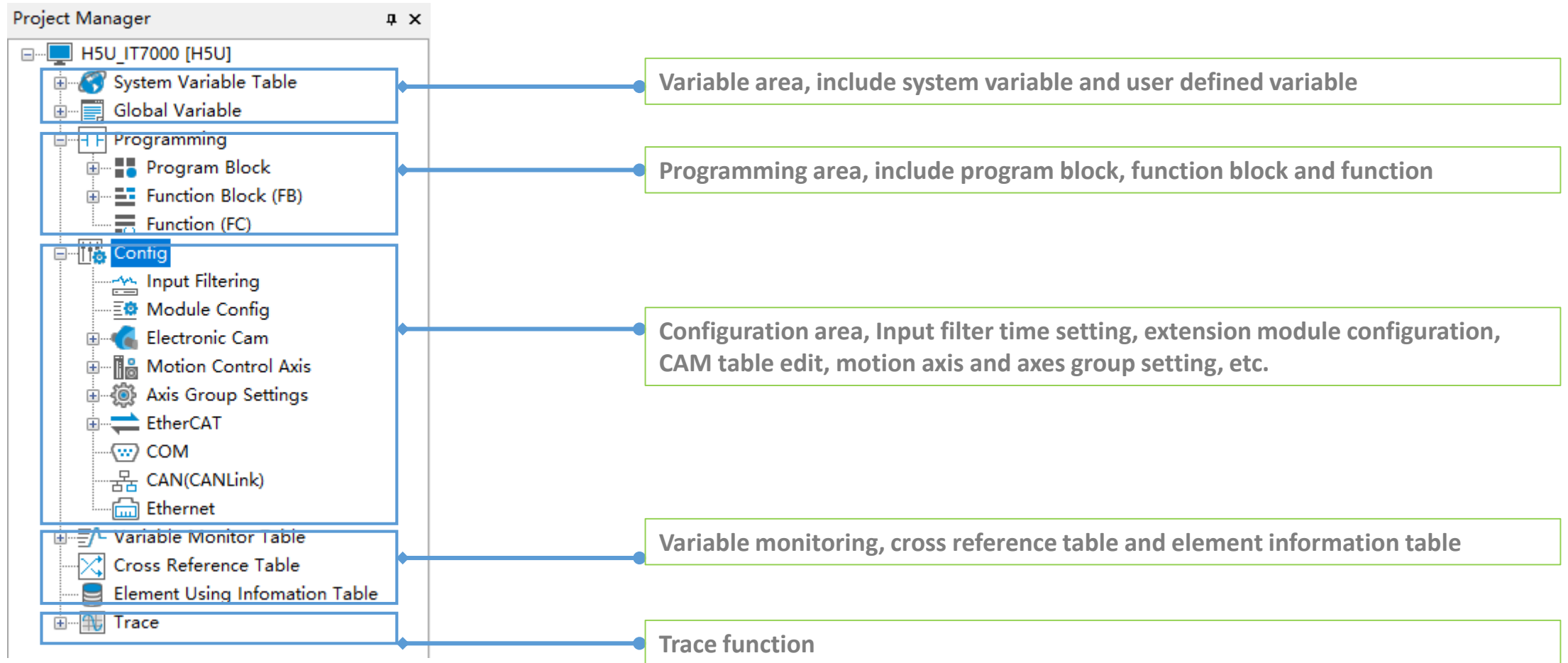

➤ Toolbox

The screenshot shows a 'Toolbox' window with a search bar at the top and a tree view of components. The tree view is divided into three main sections: 'EtherCAT Devices', 'Instruction Set', and 'FB/FC'. Callouts point to the search bar, the 'EtherCAT Devices' section, the 'Instruction Set' section, and the 'FB/FC' section.

- User can search the wanted item in this area** (points to the search bar)
- EtherCAT device, double click to add to EtherCAT configuration** (points to the 'EtherCAT Devices' section)
- Instruction guidance, double click to add to program edit area** (points to the 'Instruction Set' section)
- If users use a self defined function block, they can find the FB/FC in this area, double click to add to program edit area** (points to the 'FB/FC' section)

➤ Program Edit Area

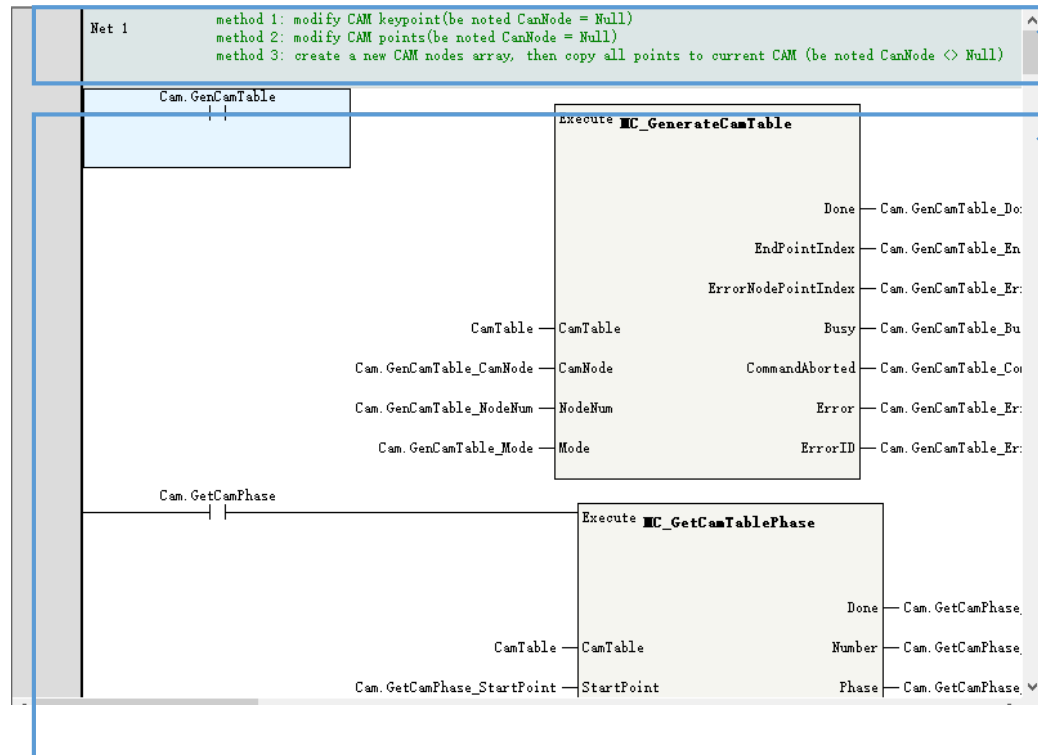

Comment area for a network

Programming area

Network is the basic unit of a program, a program consists of different networks and a project consists of different programs (main program/sub program/interruption program)

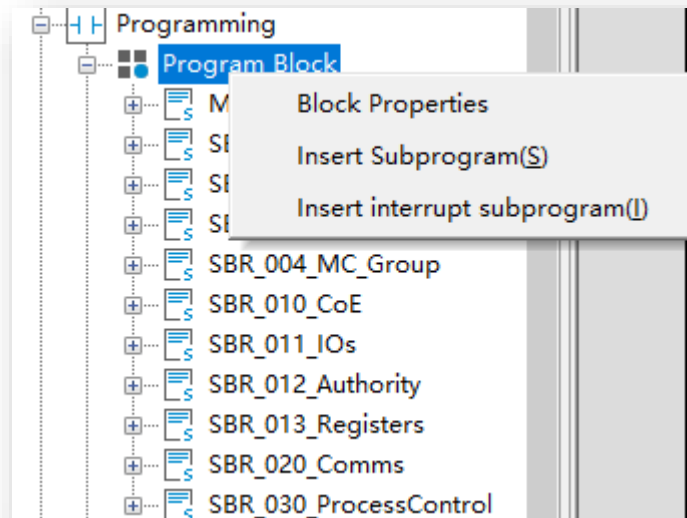

UI Introduction

➤ Fast Tool Bar



Fast tool bar integrated normal used function button for fast editing purpose, such like open/create/save a project, programming edit tool, online simulation and compile/download, etc. Users can add/delete the tool bar according the real demand. Users can right click in this area to select the wanted tools(Normally not recommend to modify this area).

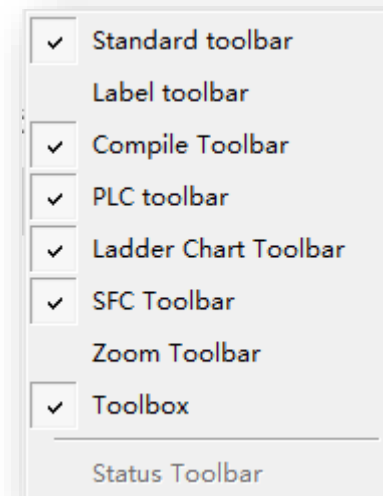

Project Basic Setting

➤ PLC program executing cycle

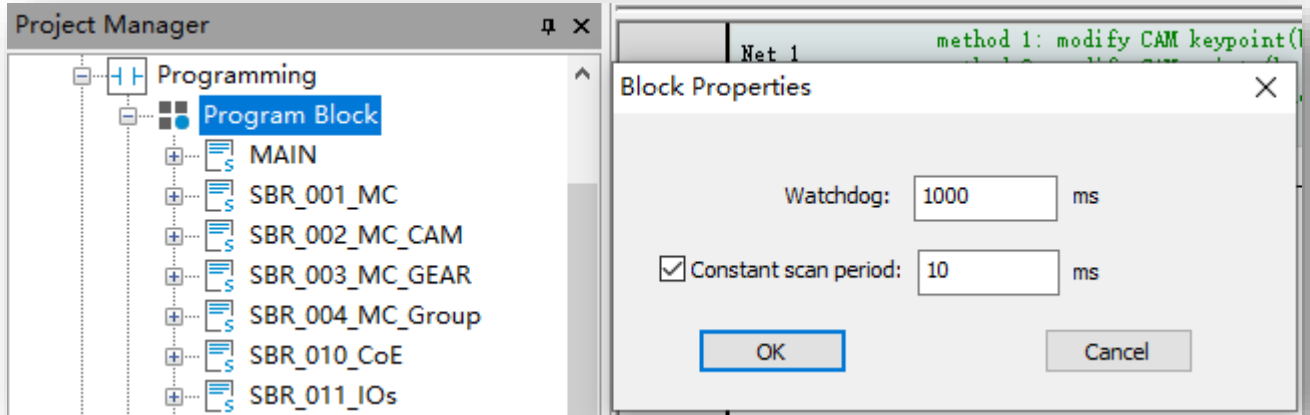

In the <Project Manager>—<Programming>, double click <Program Block> to get into project executing cycle setting view.

If <Constant scan period> not checked, the scan cycle decided by the real scan time

If <Constant scan period> checked, the scan cycle will follow the preset time, be noted while the real executing time greater than the preset constant time, the scan cycle will follow the real project executing time

<Watchdog> is used to monitoring the project executing, if the executing time over the watchdog time, the error will occur, in this case, please increase the watchdog time appropriately or check the program logic. If the program logic is complicated and need time to calculation, users can use the WDT instruction in the program to restore the monitoring time.

Project Basic Setting

➤ Input filter Setting

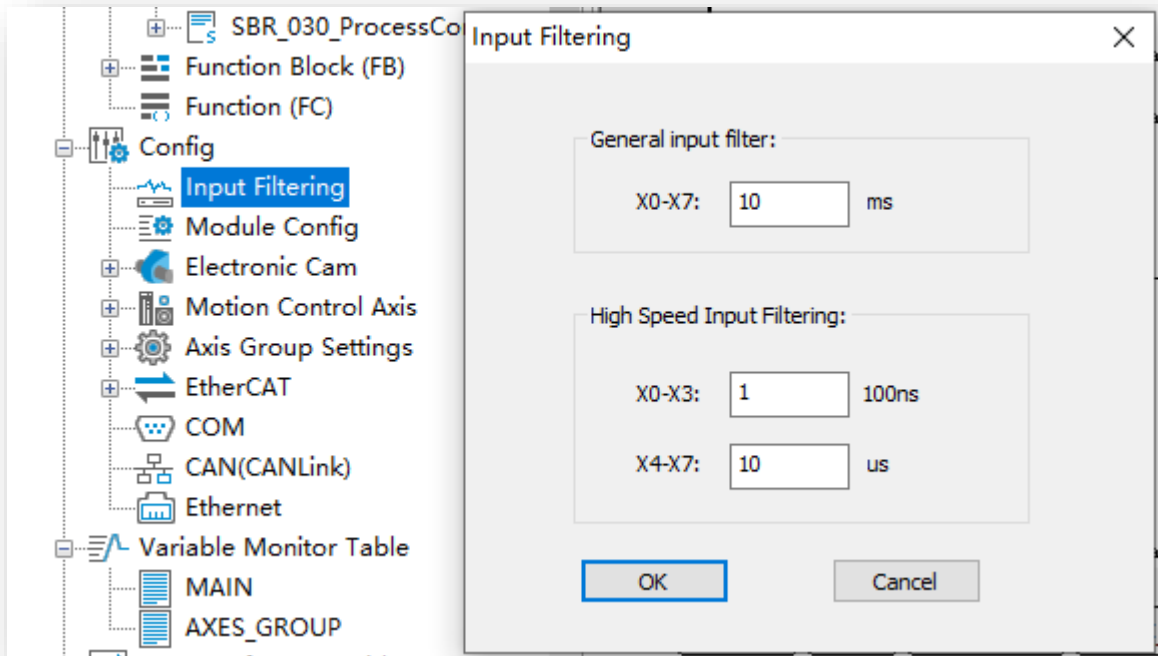

In the <Project Manager>—<Config>, double click <Input Filtering> to get into project input filter setting view.

While using external high speed input(encoder/or servo pulse feedback), the input frequency is high and the signal could not stable, in this case, users can adjust the input filter to filter the signal disturbance. (Usually use the default value.)

Module Configuration

H5U support up to 16 local extension modules, the configuration diagram and the supported modules show as below:

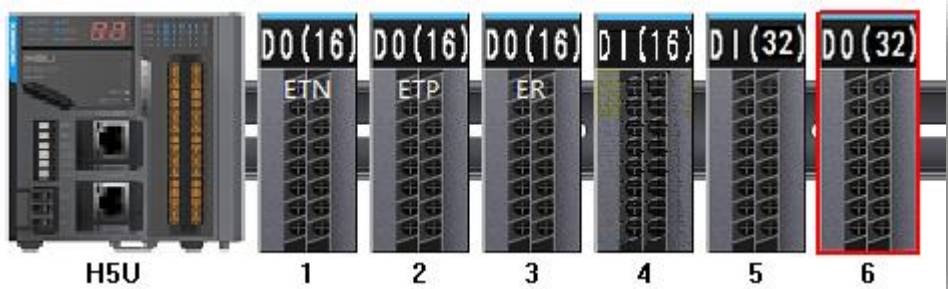

Model type	Description
GL10-0016ETN	16 NPN output module
GL10-0016ETP	16 PNP output module
GL10-0016ER	16 relay output module
GL10-1600END	16 source/sink input module
GL10-3200END	32 source/sink input module
GL10-0032ETN	32 NPN output module
GL10-4DA	4 analog output module
GL10-4AD	4 analog input module
GL10-8TC	8 channels temperature detection module (thermocouple)
GL10-4TC	4 channels temperature detection module(thermocouple)
GL10-4PT	4 channels temperature detection module(thermal resistance)

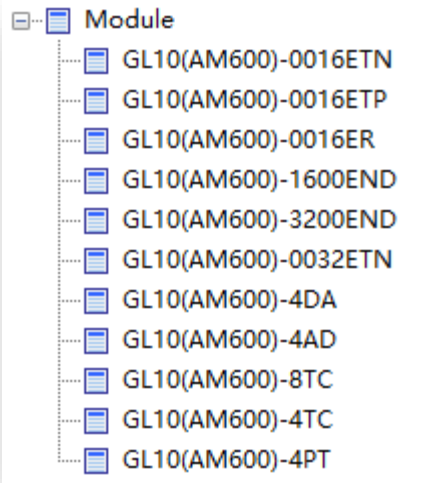

Module Configuration

The screenshot displays the 'Module Configuration' view in a software application. On the left, the 'Project Manager' tree shows the 'Module Config' option selected under the 'Config' folder. The top center shows a rack of modules with slot 4 highlighted in red. The bottom center shows a 'Device Detailed List' table with the following data:

Slot Nu...	Config Device N...	Device Description	IO Map
0	Node ID:0	H5U	X0---X:
1	GL 10(AM600)-0...	Sixteen output access of DO module(NPN Transistor output)	Y20---)
2	GL 10(AM600)-0...	Sixteen output access of DO module(PNP Transistor output)	Y40---)
3	GL 10(AM600)-0...	Sixteen output access of DO module(relay output)	Y60---)
4	GL 10(AM600)-1...	Sixteen input access of DI module	X20---)

The right pane shows a list of modules with 'GL10(AM600)-1600END' selected. A blue arrow points from this selection to a callout box.

1>Double click <Module Config> to open the module configuration view

2>Add the wanted extension module

Take note that make sure the configuration extension modules are same with the real product(sequence, quantity, model type, etc.)

3>Click the corresponding extension module to get into dedicated module setting view(**Next page**)

Module Configuration

5(GL10(AM600)-4DA)

Config(DA4) IO Mapping Module information

Report the module diagnostic

Axisle - 0

Enable channel

Report the channel diagnostic

Translation Mode: -10V~10V(-20000~20000)

Output state after Stopping

Output zero

Output Holding

Output preset

Axisle - 1

Enable channel

Report the channel diagnostic

Translation Mode: -10V~10V(-20000~20000)

Output state after Stopping

Output zero

Output Holding

Output preset

Axisle - 2

Enable channel

Report the channel diagnostic

Translation Mode: -10V~10V(-20000~20000)

Output state after Stopping

Output zero

Output Holding

Output preset

Axisle - 3

Enable channel

Report the channel diagnostic

Translation Mode: -10V~10V(-20000~20000)

Output state after Stopping

Output zero

Output Holding

Output preset

The parameters meaning please refer to the corresponding module's guidance.

Click <...> to assign the variable or soft element to extension module's input/output

5(GL10(AM600)-4DA)

Config(DA4) IO Mapping Module information

Axisle Mapping Element	Axisle	Type
...	CH0	INT
...	CH1	INT
...	CH2	INT
...	CH3	INT

Variable Input Assistant

Element name: X0 Search Expand Node Shrink Node

- SysVar
 - ..._SYS_CAN
 - ..._SYS_COM
 - ..._SYS_ECATA_MA
 - ..._SYS_ECATA_SLA
 - ..._SYS_ETHERNET
 - ..._SYS_INFO
- Axis
 - ... Axis_0
 - ... Axis_1
 - ... Axis_2
 - ... Axis_6
 - ... Axis_7
 - ... Axis_X
 - ... Axis_Y
 - ... Axis_Z
 - ... GroupAxes_0
- Ecam
 - ... Ecam_0
- UserVar
 - ... COMMANDSUSA
 - ... COMUSAGE
 - ... FUNCTION BLOC
 - ... IOS
 - ... MOTIONUSAGE
 - ... NORMALUSAGE

	Element Name	Data Type	Comment
1	X0	BOOL	
2	X1	BOOL	
3	X2	BOOL	
4	X3	BOOL	
5	X4	BOOL	
6	X5	BOOL	
7	X6	BOOL	
8	X7	BOOL	
9	X10	BOOL	
10	X11	BOOL	
11	X12	BOOL	
12	X13	BOOL	
13	X14	BOOL	
14	X15	BOOL	
15	X16	BOOL	
16	X17	BOOL	
17	X20	BOOL	
18	X21	BOOL	
19	X22	BOOL	
20	X23	BOOL	
21	X24	BOOL	
22	X25	BOOL	
23	X26	BOOL	
24	X27	BOOL	

Motion Control Axis Configuration

➤ Basic Settings

Project Manager

- SBR_001_MC
- SBR_002_MC_CAM
- SBR_003_MC_GEAR
- SBR_004_MC_Group
- SBR_010_CoE
- SBR_011_IOs
- SBR_012_Authority
- SBR_013_Registers
- SBR_020_Comms
- SBR_030_ProcessControl
- Function Block (FB)
- Function (FC)
- Config
 - Input Filtering
 - Module Config
 - Electronic Cam
 - Motion Control Axis**
 - Axis_0 Add Axis
 - Axis_1 Delete All

Basic Settings:

- Axis number: 3
- Axis type: Bus Server Axis
- Input Device: Unassigned
- Output Device: InoSV660N_3
- Virtual Axis Mode
- Automap

Function Name	Process Data
Output (Controller to Device)	
Controlword	16#6040#00:Controlword
Set position	16#607a#00:Target position
Set velocity	Unassigned
Set torque	Unassigned
Modes of operation	Unassigned
Touch probe function	16#60b8#00:Touch probe function
Add velocity	Unassigned
Add torque	Unassigned

Axis number: assigned automatically

Axis type

Input device: While axis type is encoder axis, need select the input source
 Output Device: While axis type is bus axis/or local pulse axis, need select the output source

Right click <Motion Config Axis> to add an axis, then click the <Axis Name> to open the axis configuration view

Auto map to process data of EtherCAT slave, **do not manually set**

While <Virtual Axis Mode> Checked, the axis will work at virtual mode, which means there is no instant axis operated by the controller, all axis parameters generated by controller

Motion Control Axis Configuration

➤ Unit Conversation Setting

Unit Conversion Settings:

Reverse

Number of pulses in one turn by motor/encoder: Instruction Pulse Decimal

Resolution of encoder

Do not use gearbox

The amount of movement of the worktable in a circle:

Command unit in a circle

$$\text{Pulse number} = \frac{\text{Number of pulses rotated by motor/encoder[DINT]}}{\text{Moving amount of worktable rotation[REAL]}} * \text{Moving distance(Unit)}$$

Use gearbox

The amount of movement of the worktable in a circle:

Gear ratio molecule (number of teeth in (5) below):

Gear ratio denominator (number of teeth in (4) below):

Axis type is linear mode:

$$\text{Pulse number} = \frac{\text{Number of pulses rotated by motor/encoder[DINT]} * \text{Numerator of gear ratio}}{\text{Moving amount of worktable rotation[REAL]} * \text{Denominator of gear ratio}} * \text{Moving distance(Unit)}$$

Motion Control Axis Configuration

➤ Mode/Parameters Setting

Basic Settings	Mode Selection:	
Unit Conversion Settings	Encoder Mode	<input checked="" type="radio"/> Incremental Mode <input type="radio"/> Absolute Mode
Mode/Parameter Settings	Mode Settings	<input checked="" type="radio"/> Linear Mode <input type="radio"/> Rotation Mode
Home Return Settings	Software Limits	<input type="checkbox"/> Enable Negative limit value: <input type="text" value="0.00"/> Unit Forward Limit: <input type="text" value="1000.00"/> Unit
Online Debug	Error Response	Limit deceleration: <input type="text" value="5000.00"/> Unit/s ² Axis Failure Deceleration: <input type="text" value="10000.00"/> Unit/s²
	Threshold setting	Follow error threshold: <input type="text" value="100.00"/> Unit Speed reaches threshold: <input type="text" value="5.00"/> Unit/s
	Axis Speed Settings	Max speed: <input type="text" value="5000.00"/> Unit/s Max acceleration: <input type="text" value="30000.00"/> Unit/s² Jog Max speed: <input type="text" value="5000.00"/> Unit/s
	Torque setting	Max positive torque: <input type="text" value="3000"/> 0.1% Max negative torque: <input type="text" value="3000"/> 0.1%
	Options	<input type="checkbox"/> Do not enter ErrorStop state after touching a limit
	Hardware Limit Logic	Hardware Positive Limit: <input type="text" value="Positive Logic"/> Hardware Negative Limit: <input type="text" value="Positive Logic"/>

Set the encoder mode, drive working mode and velocity limit, etc.

Motion Control Axis Configuration

➤ Home Return Settings

Basic Settings

Unit Conversion Settings

Mode/Parameter Settings

Home Return Settings

Online Debug

Home signal: Unassigned

Z Signal: Unassigned

Positive Limit: Unassigned

Negative Limit: Unassigned

Home Return Direction: Unassigned

Home Input Detection Direction: Unassigned

Home return list: Zero Back?

Home return speed: 10.0 Unit/s

Home return acceleration: 100.0 Unit/s²

Home Return Close Speed: 2.0 Unit/s

Home return timeout: 50000 *10ms

Motor Z Signal

Homing switch Signal

Positive limit switch

Deceleration point signal is invalid, Positive limit switch is not met

Deceleration point signal is invalid, Encountered a positive limit switch

Deceleration point signal is valid

Condition Filter

Select Homing mode

Homing Parameters Setting

Using MC_Home to executing homing

Motion Control Axis Configuration

➤ Online Debug

Basic Settings

Unit Conversion Settings

Mode/Parameter Settings

Home Return Settings

Online Debug

Online Debug

Variable	Set Value	Actual Value	Status:
Location	0	0	<input type="text" value=""/>
Speed	0	0	<input type="text" value=""/>
Acceleration	0	0	<input type="text" value=""/>
Torque force	0	0	<input type="text" value=""/>

/	Sports	Hardware positive limit switch	Hardware negative limit switch	Home switch	Software positive limit switch	Softwar
Status	OFF	OFF	OFF	OFF	OFF	OFF

Enter Server Debug=>

Preset location Settings

Home offset Home Regress

Positive point move Jog +

Negative point move Jog -

enable

Reset

Stop

Control Mode Absolute position ▼

Target Location

Target Speed

Start

Stop

H5U support online debug without programming, it is a convenient function for machine commissioning stage.

EtherCAT Configuration

Be noted only when EtherCAT slaved added users can select corresponding <Bus Server Axis> _<Output Device> in <Motion Controller Axis> configuration

Double click in the <Toolbox> to add the device to <EtherCAT>

EtherCAT Configuration

➤ EtherCAT Setting

The screenshot displays the EtherCAT configuration interface. On the left, the Project Manager tree shows a hierarchy of axes (Axis_0 to Axis_7), Axis Group Settings, and EtherCAT. A callout box points to the EtherCAT folder with the text: "Click <EtherCAT>".

The main window is divided into two panes. The top pane, titled "General Settings", has tabs for "Information" and "state". A callout box points to the "state" tab with the text: "Click <state> to get into EtherCAT filed bus monitoring view". The "state" tab is active, showing "Distributed clock" settings: "Cycle Time" set to 4000 μ s, "Syn offset" set to 50 %, and the "Auto restart slave" checkbox checked. A callout box points to these settings with the text: "Set the cycle time and sync offset, <Auto restart slave> checked as default".

The bottom pane, titled "EtherCAT Task Monitoring", has tabs for "General Settings", "Information", and "state". The "state" tab is active, displaying monitoring metrics: "Max cycle time(μ s)", "Min cycle time(μ s)", "Cycle time(μ s)", "Max execution time(μ s)", "Min execution time(μ s)", "Execution time(μ s)", "Frame Drops Num", "Send Errors Num", "Receive Frame Timeouts Num", "Invalid Frames Received Num", and "Received mismatched frames Num". A "Reset" button is located at the bottom of this pane.

EtherCAT Configuration

➤ General Setting

General Settings

Process Data

Startup Parameters

I/O Functional Mapping

Information

State

Address _____ Extra _____

Config Addr. Enabling Expert Settings

Distributed Clock _____

Sync. Mode Selection ▾

Enable DC to sync. events μ s

Sync0: _____

SYNC0 Enables

Sync. unit cycle ▾ Cycle time(μ s)

User defined Offset time(μ s)

Sync1: _____

SYNC1 enable

Sync. unit cycle ▾ Cycle time(μ s)

User Defined Offset time(μ s)

Slave station alias _____

Alias Address Alias enabled

Write site alias

Set the sync mode, sync cycle and alias slave address. Using the default setting in this page unless when users need to set the slave alias, check the <Enabling Export Settings>

Slave station alias _____

Alias Address Alias enabled

Write site alias

EtherCAT Configuration

➤ Process Data

General Settings		Add		Edit		Delete		Collapse		Show All		PDO Assign		PDO Config		PDO Data Size		Output(Byte):10		Input(Byte):28	
Input/Output		Name	Index	Subindex	Length	Sign	SM	Type													
<input checked="" type="checkbox"/>	Output	Outputs	16#1600	16#00	10	Editabl	2														
	Output	Following error time out	16#6066	16#0	2			UINT													
	Output	Controlword	16#6040	16#0	2			UINT													
	Output	Target position	16#607A	16#0	4			DINT													
	Output	Touch probe function	16#60B8	16#0	2			UINT													
<input type="checkbox"/>	Output	Outputs	16#1701	16#00	12	F															
<input type="checkbox"/>	Output	Outputs	16#1702	16#00	19	F															
<input type="checkbox"/>	Output	Outputs	16#1703	16#00	17	F															
<input type="checkbox"/>	Output	Outputs	16#1704	16#00	23	F															
<input type="checkbox"/>	Output	Outputs	16#1705	16#00	19	F															
<input type="checkbox"/>	Input	Inputs	16#1A00	16#00	22	Editabl															
<input checked="" type="checkbox"/>	Input	Inputs	16#1B01	16#00	28	F	3														
	Input	Error code	16#603F	16#0	2			UINT													
	Input	Statusword	16#6041	16#0	2			UINT													
	Input	Position actual value	16#6064	16#0	4			DINT													
	Input	Torque actual value	16#6077	16#0	2			INT													
	Input	Following error actual value	16#60F4	16#0	4			DINT													
	Input	Touch probe status	16#60B9	16#0																	
	Input	Touch probe pos1 pos value	16#60BA	16#0																	
	Input	Touch probe pos2 pos value	16#60BC	16#0																	

Set the RPDO(Output) and TPDO(Input) of the EtherCAT slave, while adding the slave there is default PDOs checked. Users can modify the OD in a PDO by real demand or select other pre-defined PDO. About the PDO specifications please refer to dedicated slave manual, for example, SV660N support 6 RPDO and 5 TPDO.

RPDO (Six)	1600h	Variable mapping
	1701h to 1705h	Fixed mapping
TPDO (Five)	1A00h	Variable mapping
	1B01h to 0x1B04h	Fixed mapping

EtherCAT Configuration

➤ Startup Parameters(SDO)

General Settings					
+ Add  Edit  Delete <input checked="" type="checkbox"/> Hide system parameters <input type="checkbox"/> Hex display current value					
Process Data					
NO.	Index: Subindex	Name	Value	Bit Length	
1	16#6060:16#00	Modes of operation	8	8	
2	16#1A00:16#01	1st Input Object to be mapped	1614872592	32	
Startup Parameters					
I/O Functional Mapping					
Information					
State					

Set the SDO (service data object) data. These data will be written to slave in the fieldbus start process(pre-operational state), when the field bus running(OP state), these data will not update to slave unless using CoE command to read/write a certain object dictionary. Usually users can configure some initialization parameters which not need to modify many times like gear ratio, homing acceleration/deceleration velocity, etc. If not familiar with these operation, just leave it and use the default setting.

EtherCAT Configuration

➤ I/O Functional Mapping

General Settings		<input checked="" type="checkbox"/> Hex display current value		
	Variable	Channel	Type	Current Value
Process Data	_IQ10_0	...	Controlword	UINT
	_IQ10_1	...	Target position	DINT
Startup Parameters	_IQ10_2	...	Touch probe function	UINT
	_IQ10_3	...	Physical outputs	UDINT
I/O Functional Mapping	_IQ10_4	...	Error code	UINT
	_IQ10_5	...	Statusword	UINT
Information	_IQ10_6	...	Position actual value	DINT
	_IQ10_7	...	Torque actual value	INT
State	_IQ10_8	...	Following error actual value	DINT
	_IQ10_9	...	Touch probe status	UINT
	_IQ10_10	...	Touch probe pos1 pos value	DINT
	_IQ10_11	...	Touch probe pos2 pos value	DINT
	_IQ10_12	...	Digital inputs	UDINT

Map the process data to local variable, be noted if using an EtherCAT axis, these variables can only be operated by motion control blocks.

3>Select the trace cycle—follow main cycle or EtherCAT cycle

Add Var						
	Time1	Time2	Interval			
Color	Vari...	Ruler 1	Ruler 2	Differ		
Blue	Axis...	0	0	0		
Orange	Axis...	0	0	0		
Black	Cam...	0	0	0		
Grey	Cam...	0	0	0		
Green	Cam...	0	0	0		

1>Right click to add a trace

Trigger sampling setting

4>Select the variable to monitoring

2>Click <Add Var> to add variable

5>While PLC running(or simulation), right click to download the trace

Connection with PLC

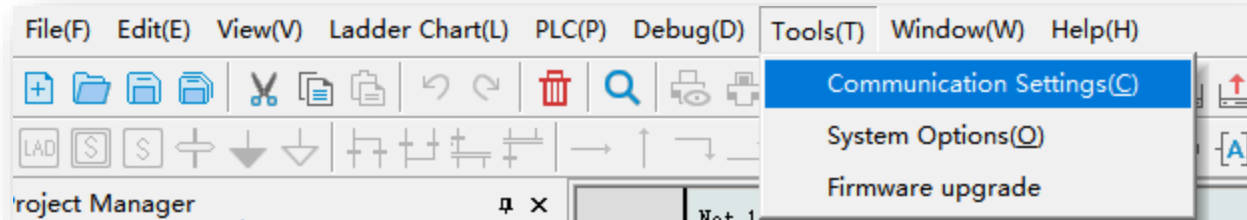

<Tool>→<Communication>

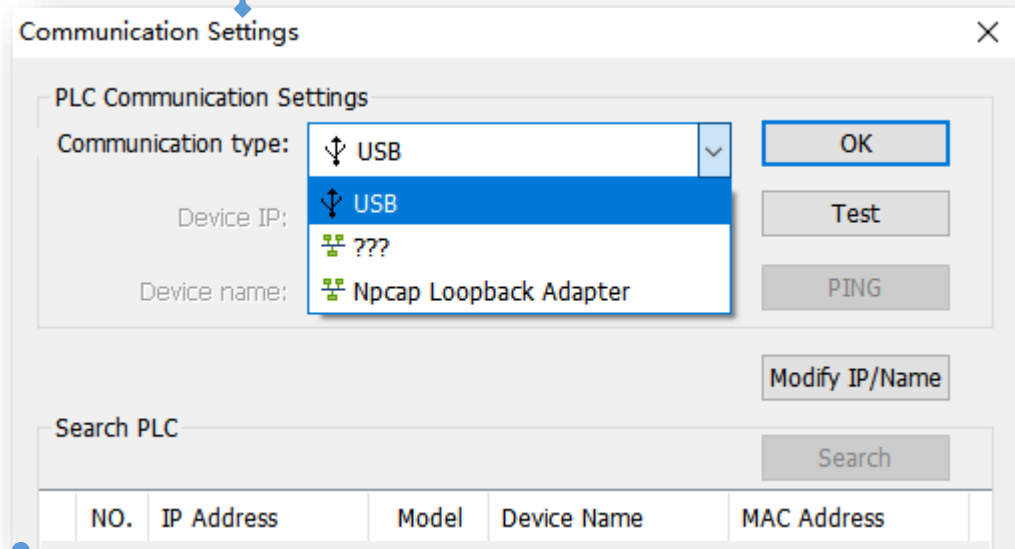

USB: using mini B port to upload/download/monitoring
???(it is software bug, will be fixed in next
version):Ethernet port

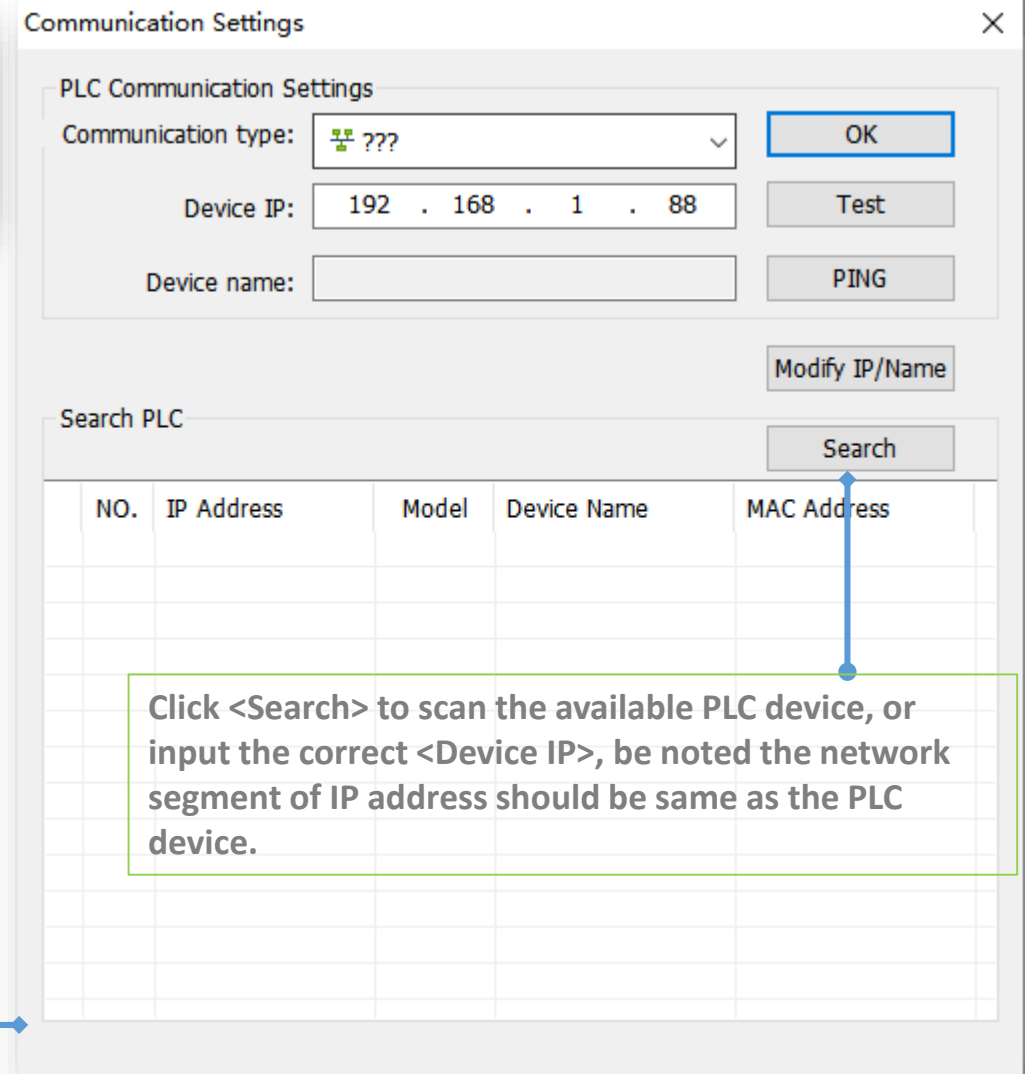

Click <Search> to scan the available PLC device, or input the correct <Device IP>, be noted the network segment of IP address should be same as the PLC device.

Connection with PLC

Communication Settings

PLC Communication Settings

Communication type: USB

Device IP: 192 . 168 . 1 . 88

Device name: PMTS_H5U

Buttons: OK, Test, PING, Modify IP/Name

Search PLC

NO.	IP Address	Model	Device Name	MAC Address
-----	------------	-------	-------------	-------------

AutoShop

Warning icon: Connection status: Connected!
Current PLC displays alternately "0"

Button: 确定

Click <Test> to check if the connection is good.

Programming Download & Upload

After connected well with PLC, select <PLC>→<Upload> or <Download> to upload/download program.

Take note:

Upload: get the program file from the H5U hardware

Download: download the program file to the H5U hardware.

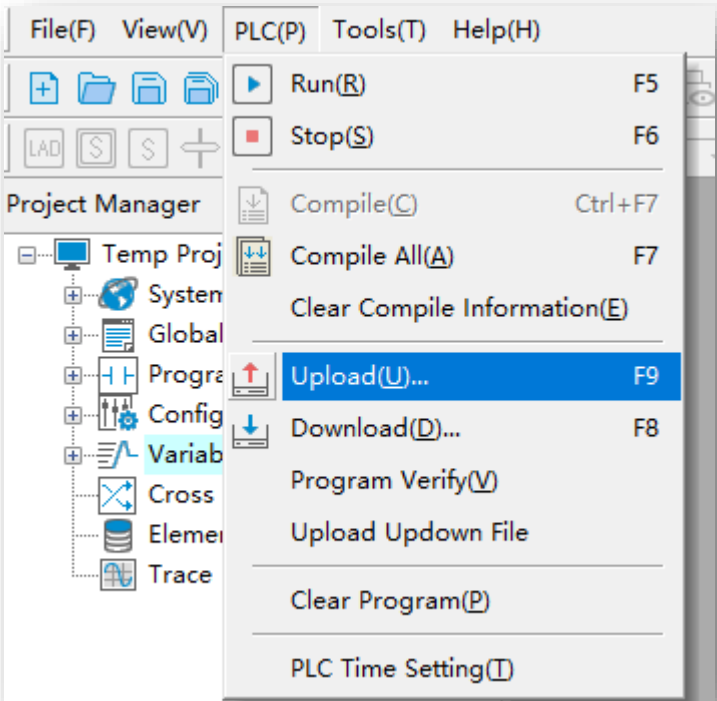

Programming Download & Upload

➤ Download

Click the <Download>, users will see a pop up window show as below:

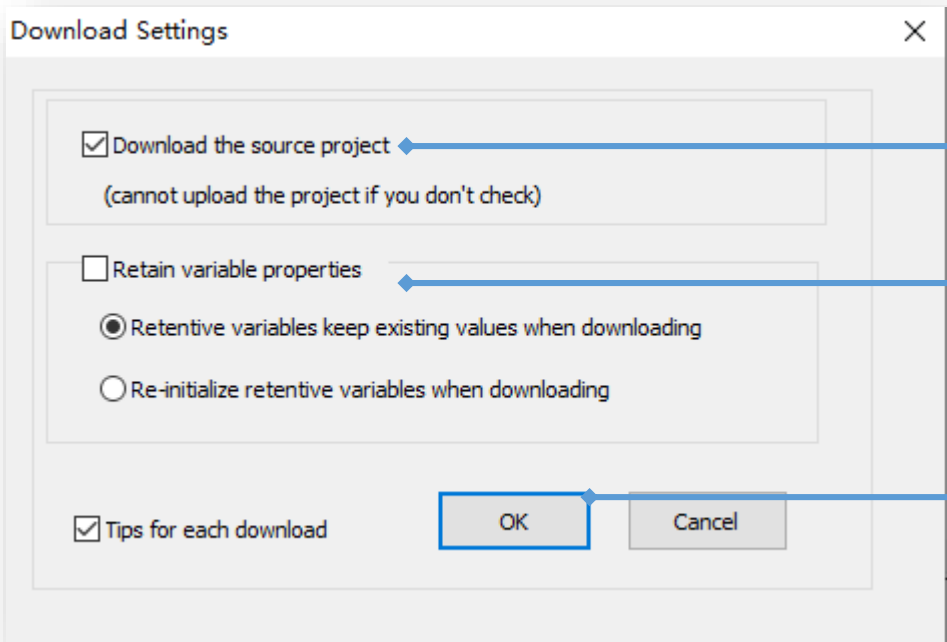

<Download the source project>: checked as default, be noted if this option unchecked, the program download to the controller will be not abled to be upload by <Upload> command.

To set the operation for non-volatile area.

Click <OK> button to continue, then below message box will show, just click <OK> button to download the program

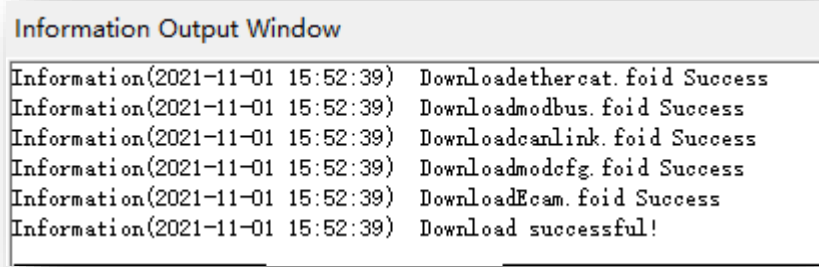

From the <Information Output Window> to check the download status.

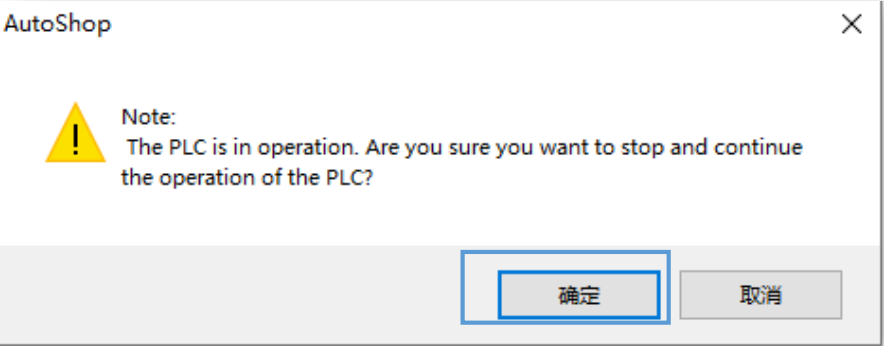

➤ Upload

Click the <Upload>, users will see a message box show as below, confirm this information, make sure the upload operation will not cover the existed valuable program (recommend to create an empty project first before to upload the program).

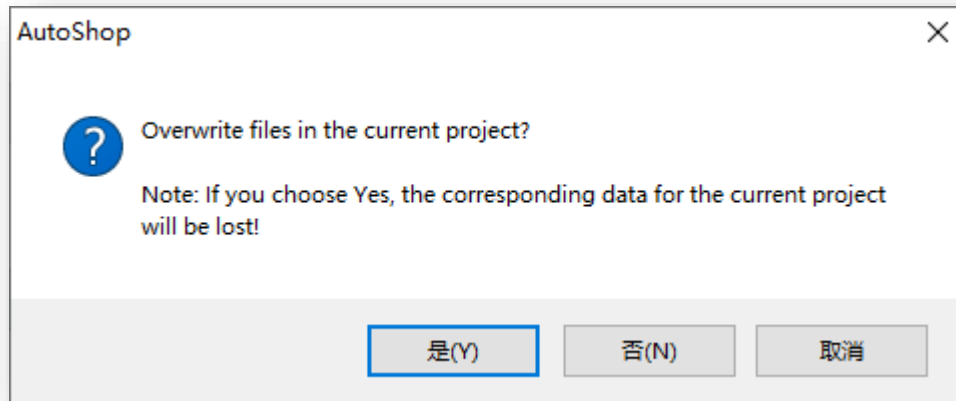

Click <Yes>, the program will be upload and cover the current project.

Take note, if the project in controller not select <Download the source project> while downloading, the project will not support to be upload!

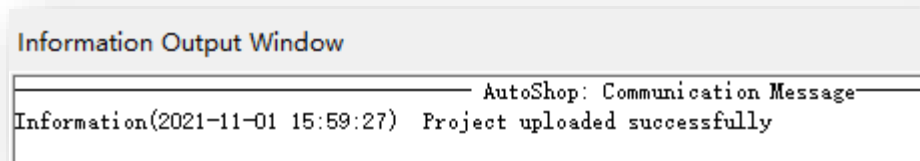

Generate Download File

[Back to Contents](#)

Download file is used to download H5U program without opening the project, there are 2 method to download the down file to PLC:
 >Using SD card to download the program
 >Using AutoShop to download the program

➤ Generate down file

Open the project, select <File> → <Generate Download File>, in the pop up window to set the down file properties.

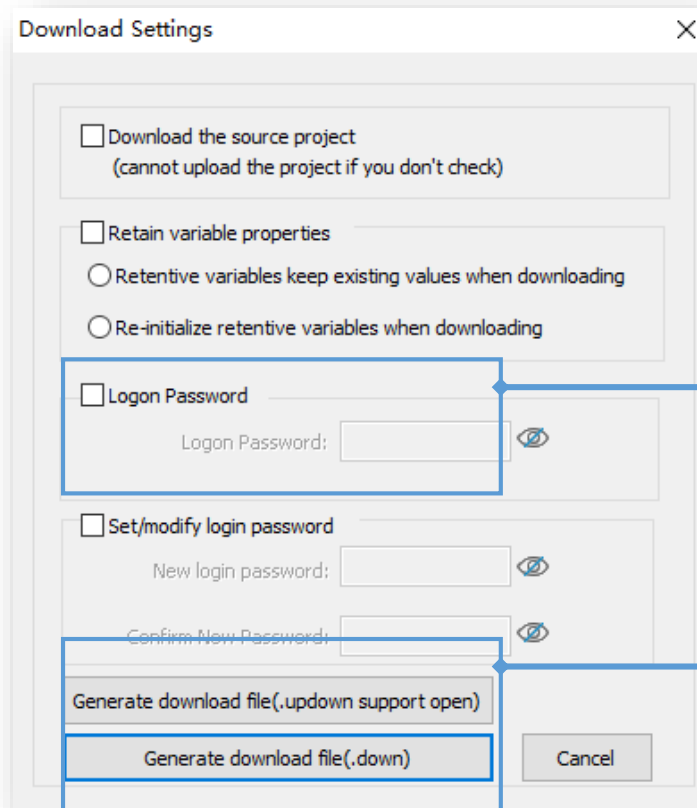
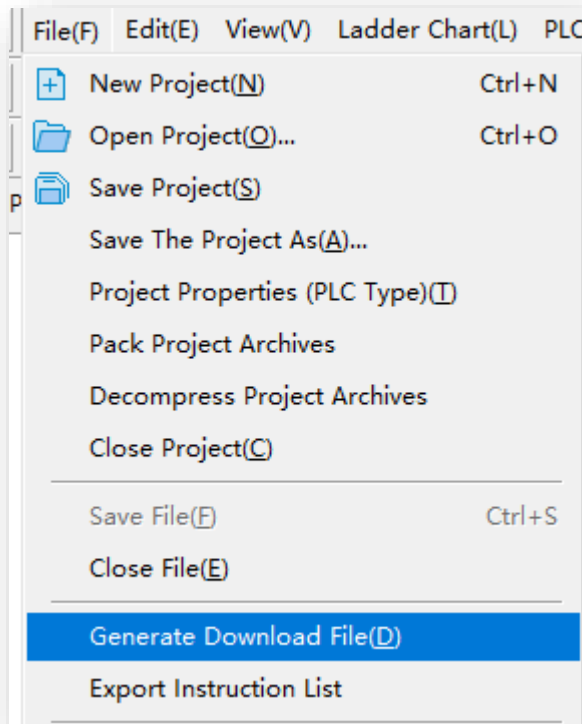

If the login password of PLC is valid, need enter the correct login password, or the generated download file cannot be download to controller.

Take note:
 There are 2 types of download file:
 .down file: cannot be upload or opened
 .updown file: can be upload and be opened

➤ Download .down/.updown file with SD

Put the generated download file to a SD card, then insert the SD card to H5U SD slot. Press the <MFK> key of H5U for 3 second to get into <SD> menu, then press <MFK> again to start the download process. The progress of downloading will show in the LED display(00~99), after downloading done, the LED display <PP>. Take note: if the password not correct, the error <E5> will display.



➤ Download .down/.updown file with Autoshop

Open Autoshop (without project opened), select <PLC> → <Download>, in the pop up window select PLC model type, click <OK> button to download the project.

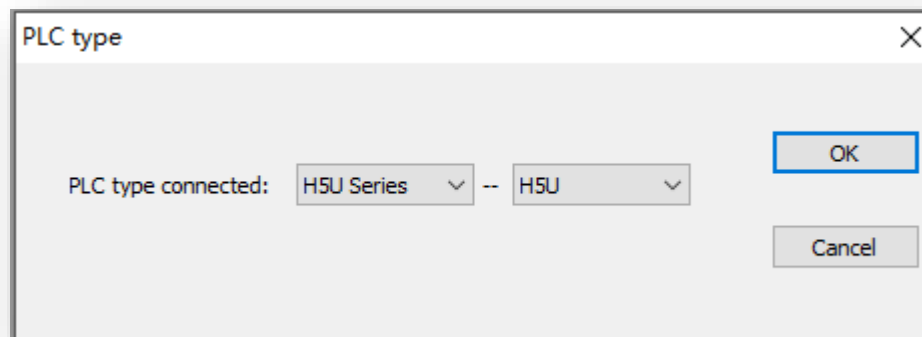
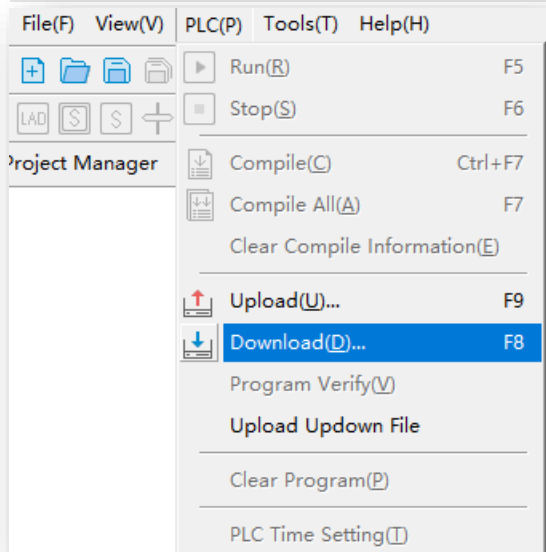

Generate Download File

➤ **Upload updown file with Autoshop**

Select <PLC> → <Upload Updown File>

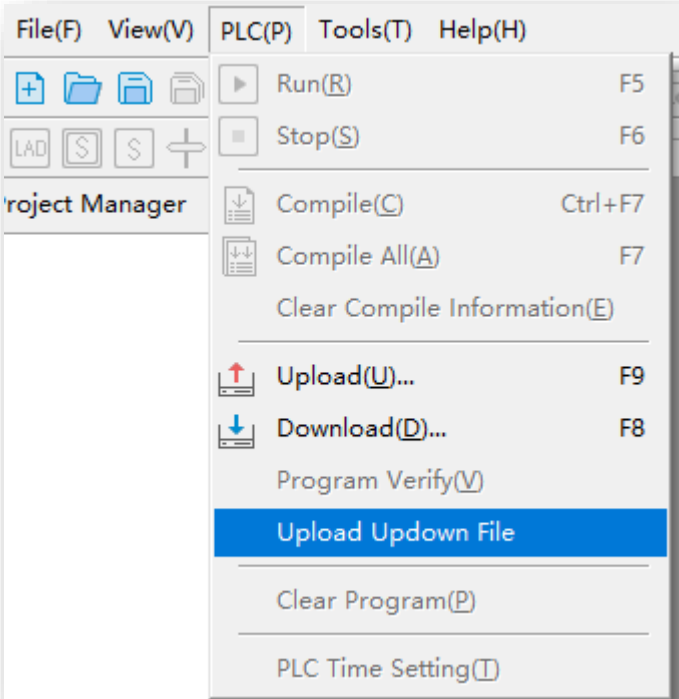

Pack Project Archives

Pack project archives function is used to pack the whole project including program/configuration/library/EDS file/XML file etc. With the archived file, users can pass the complete project to their customers without passing EDS or XML files again. In the <File> → <Pack Project Archives> to pack the current project, in the pop up window, user can select the files that need to be added into the packed archive file. Click <PACK> to continue, select save path then users can get an .hclib file.

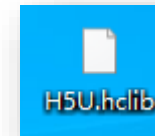
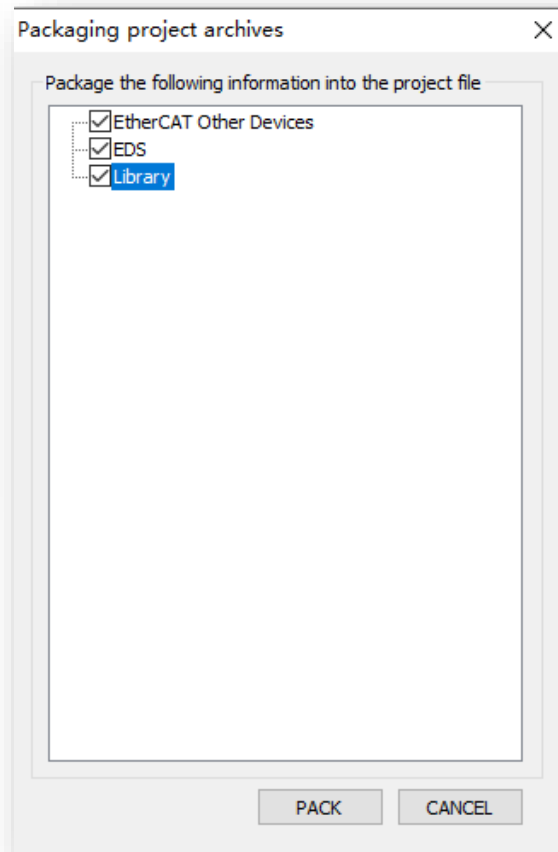
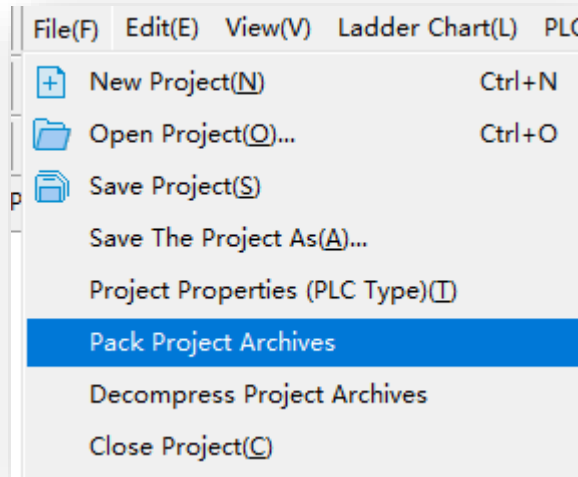

Pack Project Archives

To decompress the packed file, select <File> → <Decompress Project Archives>.

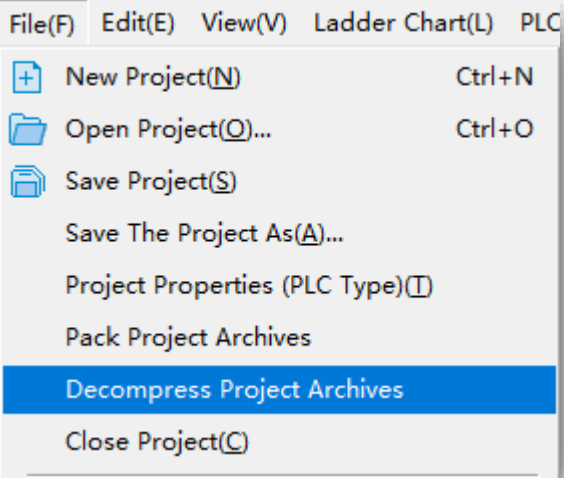

Firmware Upgrade

H5U support 2 method to upgrade firmware:
>Upgrade firmware with Authshop (Only support Ethernet connection)
>Upgrade via SD card

➤ Upgrade firmware with Autoshop

Connect with PLC via Ethernet port, make sure the connection is good, then select <Tool> → <Firmware upgrade>

The screenshot shows the 'Firmware upgrade' application window. On the left, a 'Tools(T)' menu is open, with 'Firmware upgrade' selected. The main window contains the following sections:

- PLC Info:** A 'Get PLC Info' button, 'PLC model:' text, and 'PLC software version:' text with input fields.
- PLC upgrade:** 'Select the version to upgrade:' text, a dropdown menu with a file selection icon (...), 'Enter verification code:' text, a 'Code:' field containing '289A', and an 'Upgrade' button.
- File Information:** A large empty text area at the bottom.

Three callouts with arrows point to the file selection icon, the 'Code:' field, and the 'Upgrade' button, respectively.

- 1>Select the upgrade file.
- 2>Enter the verification code
- 3>Click <Upgrade> to start upgrading

➤ Upgrade firmware with SD

1. Prepare a SD(TF) card, recommend the memory storage not over 32G.



2. Insert the SD card to a SD card read and insert the SD card read to PC USB port.

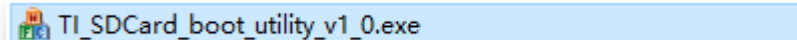

3. Double click to open the SD card tool. Users can get this tool from the local inovance representative office.

A screenshot of a Windows taskbar showing a single window titled 'TI_SDCard_boot_utility_v1_0.exe'. The window icon is a small blue square with a white 'T' and a red 'I'.

Firmware Upgrade

➤ Upgrade firmware with SD

4. Select the SD card, normally it is disk F:

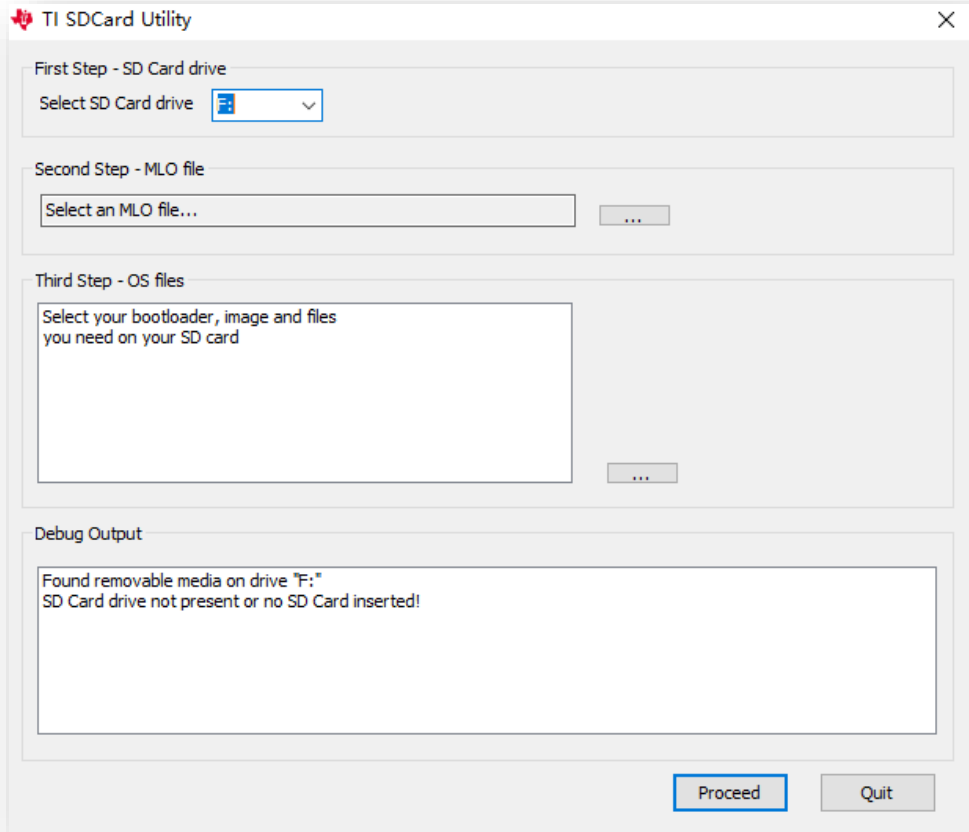

Firmware Upgrade

➤ Upgrade firmware with SD

5. Click <...> to select the MLO file in upgrade package.

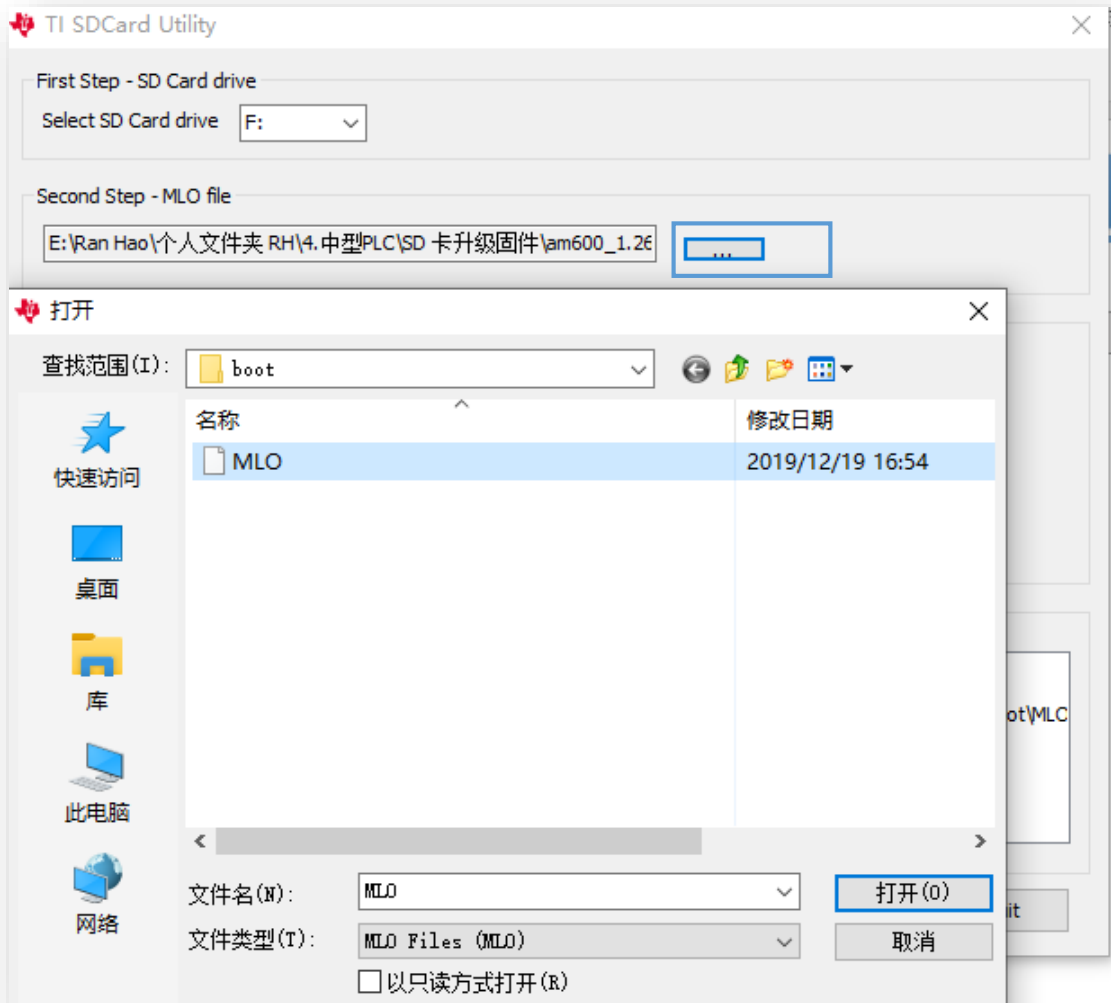

Firmware Upgrade

➤ Upgrade firmware with SD

6. Click second <...> to select all file in the pop up selection window

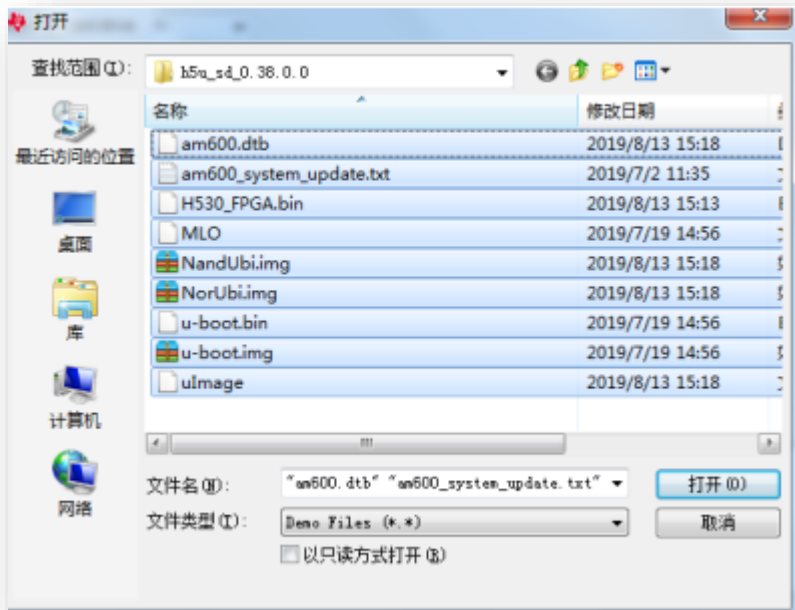
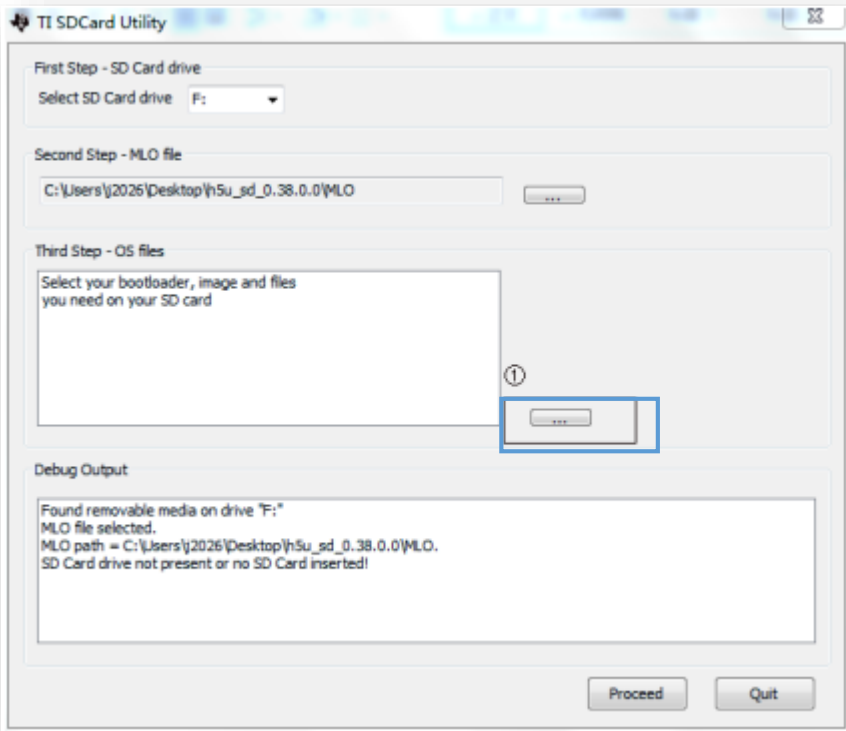

Firmware Upgrade

➤ Upgrade firmware with SD

7. Click <Process> to open the formatting view, and click <开始(S)> to start formatting the SD card

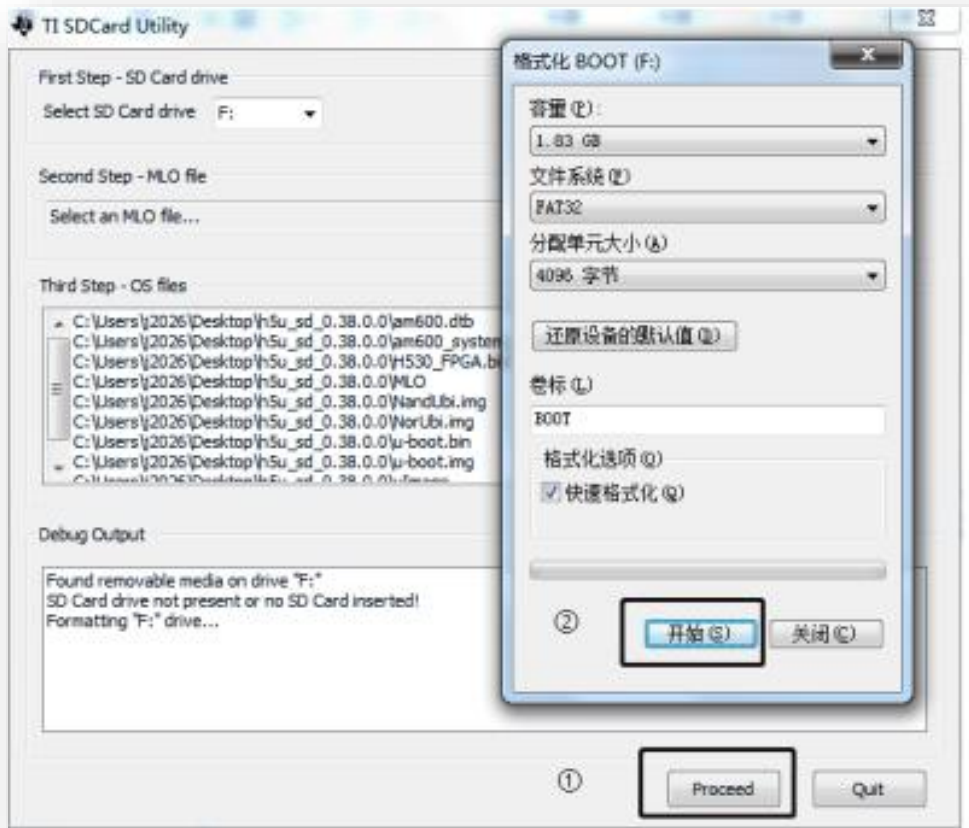

➤ Upgrade firmware with SD

8. After formatting process, click <关闭(C)> to close the formatting view, and the tool will start to make the SD card, until the <Debug Output> view show the <Copying files done>, the procedure complete.

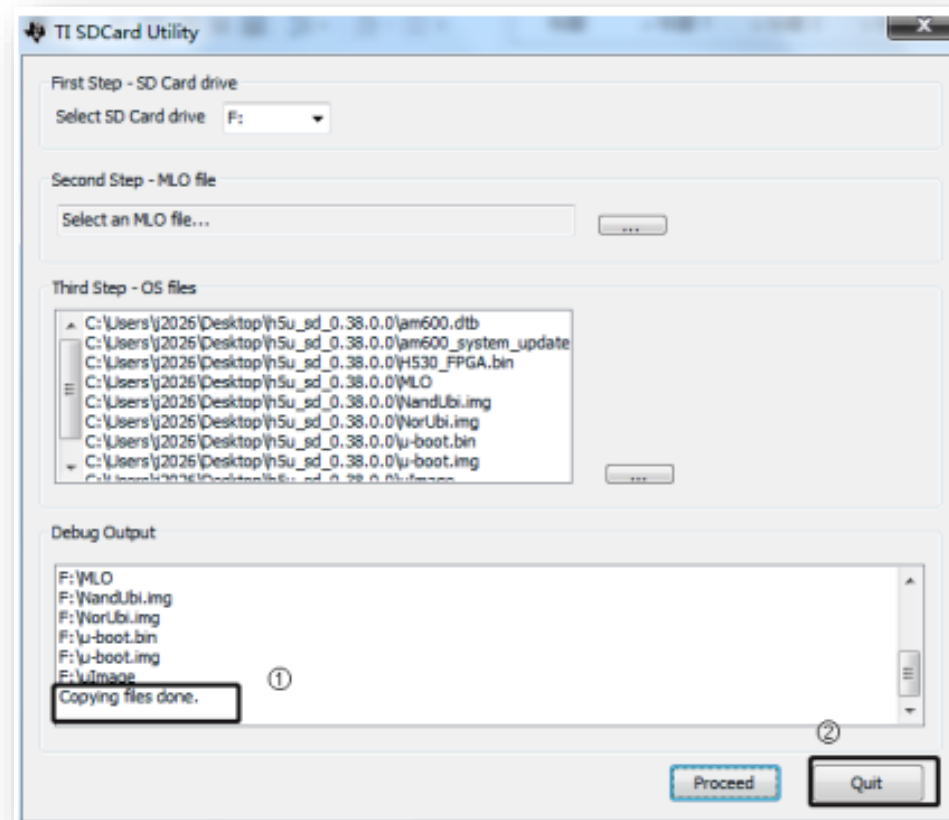

➤ Upgrade firmware with SD

9. Insert the SD card to PLC SD slot

10. Re-power the controller, the LED display <UU> to start upgrading, it will keep for about 1 minute, until the LED display <00> or <CC>, the upgrading complete, users can pull out the SD card.

Data and Memory

Memory Assignment

Soft Element
about 150KB

Which can be used in program directly, no need to clarify/or define.
X/Y/D/M/R, etc.

User Defined Variable
2MB

Before using this variable, users have to clarify/or define these variables in <Global Variable>.
The basic data type:
BOOL/INT/DINT/REAL
Advanced data type:
ARRAY/POINTER/STRUCT

System Variable

Built in variable which used to get system info like:
Time/IP/Communication State/Axis data

Soft Element

Element	Description	H3U	H5U	Comparison
X/Y	Physical Input & Output	X0~X377/Y0~Y377	X0~X1777/Y0~Y1777	IO range expand
M	Auxiliary Contact	M0~M7999	M0~M7999	H5U: M0-M999 volatile M1000 non volatile
S	Step Contact	S0~S4095	S0~S4095	H5U: S0-S999 volatile S1000+ non volatile
B	Auxiliary contact	—	B0~B32767	H5U: B0-B999 volatile B1000+ non volatile
D	Word Register	D0~D8000	D0~D8000	H5U: D0-D999 volatile D1000+ non volatile
R	Work Register	R0~R32767 (Non volatile)	R0~R32767	H5U: R0-R999 volatile R1000+ non volatile
W	Word Register	—	W0~W32767	H5U: W0-W999 volatile W1000+ non volatile

H5U have a extension of soft element compared with H3U. Besides, H5U don't allow users to modify the non-volatile area.

Special(System) Soft Element

Element	Description	H3U	H5U	Comparison
Z/V	Address Register	Z0~Z7/V0~V7	--	H5U using pointer to achieve address function
M	System Contact	M8000 +	Only keep partial	H5U: check next slide
D	System Register	D8000 +	--	--
SM/SD	System Register	System used	--	--

Compared with H3U, H5U delete most of the special registers;
 For the information provided by special registers, H5U using system variable to get these information.

Special(System) Soft Element

Element	Function
M8000	Program running monitoring
M8001	Opposite status of M8000
M8002	On in the first scan cycle of the program
M8003	Opposite status of M8002
M8011	10ms cycle clock
M8012	100ms cycle clock
M8013	1S cycle clock
M8014	1Min cycle clock

Element	Function
M8020	Operation zero flag
M8021	Operation borrow flag
M8022	Operation carry flag
M8029	Multi cycle instruction complete flag
M8040	SFC control flag
M8161	OFF-16 bit mode , ON-8 bit mode Bit process mode of ASCII / HEX / CCD / LRC / CRC / RS
M8163	BINDA output string last byte(00h or 20h)
M8165	SORT2 descending sort enable flag
M8168	SMOV data format set, OFF-BCD mode, ON-HEX mode

System Variable

System Variable	Description
_SYS_CAN	CAN communication related info, like station number, baud rate, slave online status, etc.
_SYS_COM	COM communication related info, like station number, baud rate, slave online status, etc.
_SYS_ECAT_MASTER	EtherCAT Master info
_SYS_ECAT_SLAVE	EtherCAT Slave info
_SYS_ENCODER_AXIS	External encoder info
_SYS_ETHERNET	Ethernet communication info, like IP, MAC, online status, error diagnosis, etc.
_SYS_INFO	PLC system info, like SN, firmware version, RTC, module diagnosis, system log, etc.

System variable is used to describe the system status.

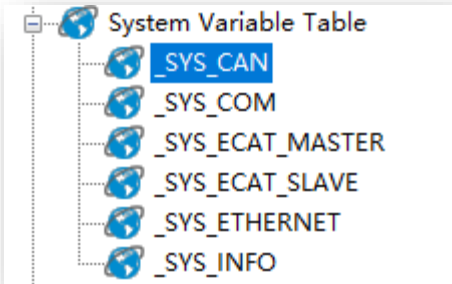

System Variable

The screenshot displays the 'Variable Input Assistant' dialog box. The 'Element name' field contains 'X0'. The dialog lists various system variables with their corresponding data types and comments. The background shows a 'Project Manager' tree on the left and a table of system variables in the center.

Element Name	Data Type	Display Format	Comment
1	...	+	Axis[0]
91	...	+	Axis[1]
181	...	+	Axis_1
282	...	+	Axis_0
343	...	+	Ecam_0
2519	...	+	Cam
2701	...	+	MC_CAMO
5222	...	+	MC_Gear
5423	...	+	sendbuf
5424	...	+	resbuf

Element Name	Data Type	Comment	
1	_DevInfo	_sDEV_INFO	Device Information
2	Device	INT	Device Model ID
3	Vender	INT	Manufacturer ID
4	HWVersion	DINT	Hardware Version
5	SWVersion	DINT	Software Version
6	FPGAVersion	DINT	FPGA version
7	NSTDVersion	DINT	Non-standard Version
8	_OSM	_sOSM	System Monitor
9	CPU	INT	CPU utilization
10	Memory	INT	Memory Utilization
11	_Program	_sPROGRAM	User Program Information
12	TotalSize	DINT	Total program capacity
13	UsedSize	DINT	Used Program Capacity
14	Interval	DINT	Program Task Cycle, us
15	CurPeriod	DINT	Current program task cycle, us
16	MinPeriod	DINT	Minimum program task cycle, us
17	MaxPeriod	DINT	Maximum program task cycle, us
18	CurRunTime	DINT	Current program run time, us
19	MinRunTime	DINT	Minimum program run time, us
20	MaxRunTime	DINT	Maximum program run time, us
21	AveRunTime	DINT	Average program run time, us
22	Reset	BOOL	Reset Cycle Time
23	_CurErrLst	_sERR_LST	Current Error List
24	Quantitv	INT	Current number of errors

Check the system variable status in <Variable Monitor Table>.

System Variable

Program example: read RTC via system variable.

```

Net 1      Net Comment
-----
M8000
Program run flag, run: ON, stop: OFF
[  MOV  _DateTime.Year      D0
   Year
]
[  MOV  _DateTime.Month    D1
   Month, in [1,12]
]
[  MOV  _DateTime.Day      D2
   day, the date of a month, with a range of
]
[  MOV  _DateTime.Hour     D3
   when the value interval is [0,23]
]
[  MOV  _DateTime.Minute   D4
   Score, value interval [0,59]
]
[  MOV  _DateTime.Second   D5
   seconds, with a range of [0,60], and 60 leap seconds
]
    
```

- ..._SYS_ETHERNET
- ..._SYS_INFO
- Axis
- Axis_0
- Axis_1
- Axis_2
- Axis_6
- Axis_7
- Axis_X
- Axis_Y
- Axis_Z

Address	Variable Name	Data Type	Description
236	DateTime	sDATE_TIME	Date and Time
237	Second	INT	seconds, with a range of [0,60], and 60 leap seconds
238	Minute	INT	Score, value interval [0,59]
239	Hour	INT	when the value interval is [0,23]
240	Day	INT	day, the date of a month, with a range of [1,12]
241	Month	INT	Month, in [1,12]
242	Year	INT	Year
243	WeekDay	INT	Week, with a range of [0,6], where 0 is Sunday
244	YearDay	INT	Days starting on January 1 of each year
245	Timestamp	DINT	The total number of seconds from 00:00:00 on January 1, 2000

User Defined Variable

H5U provide 2M storage for user defined variable, and 256KB of the storage support non-volatile save.

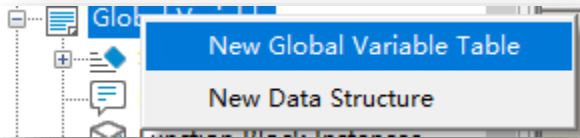

<Global Variable> right click to add <New Global Variable Table>

System assign the variable address, no need to consider the soft element address distribution, besides, name the variable according to the variable meaning, no need add extra comment, the program will be more readable.

NO.	Variable...	Data Type	Initial Value	Power Down Hold	Comment	Element Addr.	Length	CurValue	<input checked="" type="checkbox"/> Value1	<input type="checkbox"/> Value2
1	sTCP	Stru_TCPSocket	...	Non Retained			nBitLen:224			
30	aSenBuf_TCP	INT[50]	...	Non Retained			nBitLen:800			
81	aRecBuf_TCP	INT[50]	...	Non Retained			nBitLen:800			
132	xEnable_TCP	BOOL	OFF	Non Retained			nBitLen:1			
133	iSenSize_TCP	INT	0	Non Retained			nBitLen:16			
134	IRecSize_TCP	INT	0	Non Retained			nBitLen:16			
135	sUDP	Stru_UDPSocket	...	Non Retained			nBitLen:224			
152	aSendBuf_UDP	INT[50]	...	Non Retained			nBitLen:800			
203	aRecBuf_UDP	INT[50]	...	Non Retained			nBitLen:800			
254	xEnable_UDP	BOOL	OFF	Non Retained			nBitLen:1			
255	iSenSize_UDP	INT	0	Non Retained			nBitLen:16			
256	IRecSize_UDP	INT	0	Non Retained			nBitLen:16			
257	aSenBuf_Se...	INT[256]	...	Non Retained			nBitLen:4096			
514	iSenSize_S...	INT	0	Non Retained			nBitLen:16			
515	aRecBuf_Se...	INT[256]	...	Non Retained			nBitLen:4096			
772	iRecSize_S...	INT	100	Non Retained			nBitLen:16			
773	xSerialExe...	BOOL	OFF	Non Retained			nBitLen:1			
774	SerialSR_Done	BOOL	OFF	Non Retained			nBitLen:1			
775	SerialSR_S...	INT	0	Non Retained			nBitLen:16			
776	SerialSR_Sent	INT	0	Non Retained			nBitLen:16			
777	SerialSR_R...	INT	0	Non Retained			nBitLen:16			
778	iRec_Timeout	INT	0	Non Retained			nBitLen:16			
779										

Enter the variable in program, support input assistant. If the variable not defined, after enter the variable, it will automatically added in variable table.

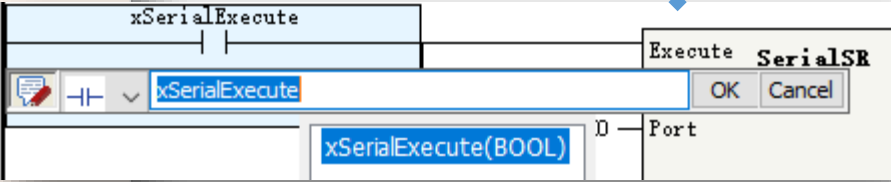

User Defined Variable

➤ Data Type

H5U support below data type:

ARRAY

BOOL: 1 bit, 0 or 1

INT: 16 bit signed integer, take 2 byte

DINT: 32 bit signed integer, take 4 byte

REAL: 32 bit float number, take 4 byte

POINTER: point to address

STRUCT

Data Type	In
Stru_TCPS...	...
ARRAY	
BOOL	
INT	
DINT	
REAL	
POINTER	
Stru_AxesGroup	
Stru_Axis	
Stru_CAM	
Stru_CoE	
Stru_Gear	
Stru_TCPSocket	
Stru_UDPSocket	
_sPOINT2D	
_sPOINT3D	
_sGROUPPOS_INFO	
_sMC_CAM_NODE	
_sMC_CAMLN	

NO.	Member name	Data type
1	AxisID	INT
2	Enable	BOOL
3	MCPower_Status	BOOL
4	MCPower_Busy	BOOL
5	MCPower_Error	BOOL
6	MCPower_ErrorID	INT
7	MCSetsPos_Exec...	BOOL
8	MCSetsPos_Pos...	REAL
9	MCSetsPos_Mode	INT
10	MCSetsPos_Done	BOOL
11	MCSetsPos_Busy	BOOL
12	MCSetsPos_Error	BOOL
13	MCSetsPos_Err...	INT
14	MCJog_Enable	BOOL
15	MCJog_FWD	BOOL
16	MCJog_BWD	BOOL
17	MCJog_VEL	REAL
18	MCJog_ACC	REAL
19	MCJog_DEC	REAL
20	MCJog_CurveType	INT
21	MCJog_Busy	BOOL
22	MCJog_CMDAbo...	BOOL
23	MCJog_Error	BOOL
24	MCJog_ErrorID	INT
25	MCMoveVel_Exec...	BOOL
26	MCMoveVel_VEL	REAL
27	MCMoveVel_ACC	REAL
28	MCMoveVel_DEC	REAL
29	MCMoveVel_Cu...	INT
30	MCMoveVel_In...	BOOL
31	MCMoveVel_Busy	BOOL
32	MCMoveVel_CM	BOOL

STRUCT include different sub item or object property.

18	VAR	PT_M	POINTER	NULL	Non Retained
19	VAR	PT_D	POINTER	NULL	Non Retained
20	VAR	PT_X	POINTER	NULL	Non Retained
21	VAR	PT_Y	POINTER	NULL	Non Retained
22	VAR	PT_S	POINTER	NULL	Non Retained

Net 2	Net Comment
M8000	
[PTGET PT_M MO]	Program run flag, run: ON, stop: OFF
[PTGET PT_X XO]	
[PTGET PT_Y YO]	
[PTGET PT_S SO]	
[PTGET PT_B BO]	

Point initial value is NULL, using PTGET instruction to get the point value—Point to a certain address.

User Defined Variable

➤ Work Area

Besides global variable, H5U also support create a variable in a function block, the difference show as below:
 Global variable: works in whole project, system variables and soft elements are global variable, users can invoke this variable at any place in program.
 Local variable: works only in current function block, other program/or function block cannot using the variables.

NO.	I/O Type	Name	Data Type	Initial Value	Power Down Hold	Comment
1	IN	Master	_sMCAXIS_INFO	...	Non Retained	
2	INOUT	Slave	_sMCAXIS_INFO	...	Non Retained	
3	INOUT	CamTable	_sMC_CAMTABLE	...	Non Retained	
4	INOUT	Cam	Stru_CAM	...	Non Retained	
5						

Annotations in the image:

- A box labeled "Local Variable" points to the "Cam" variable in the table.
- A box labeled "Global Variable" points to the "CamTable" variable in the table.
- Another "Global Variable" box points to the "MC_CAM" function block in the Project Manager tree.

```

Net 1
method 1: modify CAM keypoint(be noted CanNode = Null)
method 2: modify CAM points(be noted CanNode = Null)
method 3: create a new CAM nodes array, then copy all points to current

Cam.GenCamTable
Execute MC_GenerateCamTab
    
```

User Defined Variable

➤ Array

Array is an ordered sequence of elements. All elements in a array are same data type. H5U support 1 dimension array.

19	GetCamPhase_...		▼
20	GetCamPhase_...	ARRAY	
21	GetCamPhase_...	BOOL	
22	GetCamDistance	INT	
23	GetCamDistan...	DINT	
		REAL	
		Stru_AxesGroup	

Define Array ✕

Type: REAL ▼

Length: 10

OK Cancel

Set the data type and length of an array, for example, if the length set as 2, then there are 2 elements in this array: <arrayname>.[0], <arrayname>.[1]

Variab...	Data Type
[-] Axis	Stru_Axis[31]
[+] Axis[0]	Stru_Axis
[+] Axis[1]	Stru_Axis
[+] Axis[2]	Stru_Axis
[+] Axis[3]	Stru_Axis
[+] Axis[4]	Stru_Axis
[+] Axis[5]	Stru_Axis
[+] Axis[6]	Stru_Axis
[+] Axis[7]	Stru_Axis
[+] Axis[8]	Stru_Axis
[+] Axis[9]	Stru_Axis
[+] Axis[10]	Stru_Axis
[+] Axis[11]	Stru_Axis
[+] Axis[12]	Stru_Axis
[+] Axis[13]	Stru_Axis
[+] Axis[14]	Stru_Axis
[+] Axis[15]	Stru_Axis
[+] Axis[16]	Stru_Axis
[+] Axis[17]	Stru_Axis
[+] Axis[18]	Stru_Axis
[+] Axis[19]	Stru_Axis
[+] Axis[20]	Stru_Axis
[+] Axis[21]	Stru_Axis
[+] Axis[22]	Stru_Axis
[+] Axis[23]	Stru_Axis
[+] Axis[24]	Stru_Axis
[+] Axis[25]	Stru_Axis
[+] Axis[26]	Stru_Axis
[+] Axis[27]	Stru_Axis
[+] Axis[28]	Stru_Axis
[+] Axis[29]	Stru_Axis

User Defined Variable

➤ Structure

Structure is a new data type composed of a batch of data. In most project, axis reference structure is normally used which include related operations and properties of an axis.

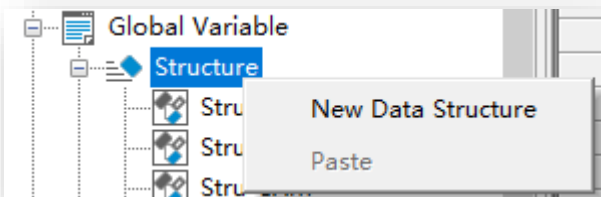

<Structure> right click to add <New Data Structure>

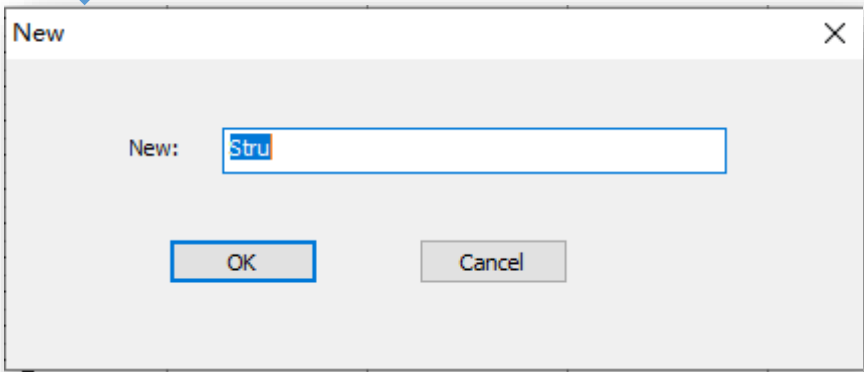

1	Axis	Stru_Axis[31]	...
2	Axis[0]	Stru_Axis	...
3	AxisID	INT	0
4	Enable	BOOL	OFF
5	MCPower_Status	BOOL	OFF
6	MCPower_Busy	BOOL	OFF
7	MCPower_Error	BOOL	OFF
8	MCPower_ErrorID	INT	0
9	MCSetsPos_Execute	BOOL	OFF
10	MCSetsPos_Pos...	REAL	0.000000
11	MCSetsPos_Mode	INT	0
12	MCSetsPos_Done	BOOL	OFF
13	MCSetsPos_Busy	BOOL	OFF
14	MCSetsPos_Error	BOOL	OFF
15	MCSetsPos_ErrorID	INT	0
16	MCJog_Enable	BOOL	OFF
17	MCJog_FWD	BOOL	OFF
18	MCJog_BWD	BOOL	OFF
19	MCJog_VEL	REAL	1000.000
20	MCJog_ACC	REAL	1000.000
21	MCJog_DEC	REAL	1000.000
22	MCJog_CurveType	INT	0
23	MCJog_Busy	BOOL	OFF
24	MCJog_CMDAborted	BOOL	OFF
25	MCJog_Error	BOOL	OFF
26	MCJog_ErrorID	INT	0
27	MCMoveVel_Exec...	BOOL	OFF
28	MCMoveVel_VEL	REAL	1000.000
29	MCMoveVel_ACC	REAL	1000.000
30	MCMoveVel_DEC	REAL	1000.000
31	MCMoveVel_Cur	TNT	0

User Defined Variable

➤ Pointer

Pointer is variable which used to store the internal memory address, to provide the method to operate variable address.

VAR	PT_M	POINTER	▼	NUM
VAR	PT_D	ARRAY		
VAR	PT_X	BOOL		
VAR	PT_Y	INT		
VAR	PT_Z	DINT		
VAR	PT_S	REAL		
VAR	PT_R	POINTER		

PT operation instruction	
Instruction	Description
PTGET	Get the address of pointer
PTINC	Increase pointer address by 1
PTDEC	Decrease pointer address by 1
PTADD	Add pointer address by set offset
PTSUB	Decrease pointer address by set offset
PT>, PT>=, PT<, PT<=, PT=, PT<>	PT variable address comparison

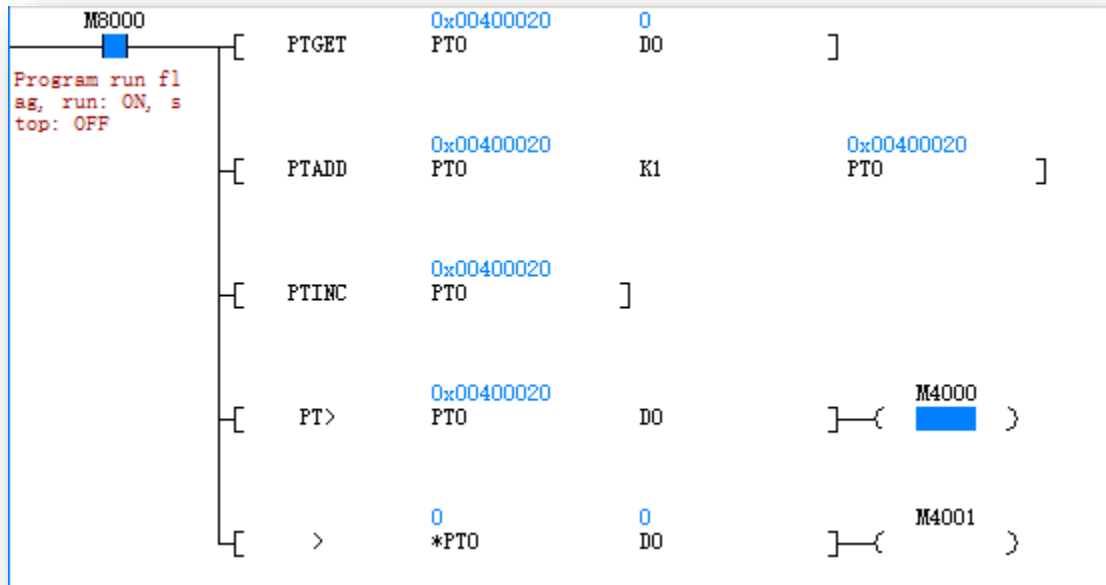

Before using a pointer, have to use <PTGET> to get an variable address. This instruction means PTO point to D0.

Add the pointed address. This instruction means PTO point to D1

Add the pointed address by 1. This instruction means PTO point to D2

PT compared instruction. Means compare the value of register address

Normal compared instruction. Means compare the value of registers

Instruction Introduction

Instructions

All available instructions can be found in <Toolbox>→<Instruction Set>, most of basic instruction and data processing instruction are same with H3U, for motion control or high speed IO instruction, H5U have totally different style (conform PLCopen, will be introduced in next chapters)

The screenshot shows the 'Apply instructions' dialog box with the following details:

- Instruction Category: All instructions
- Instruction Name: BTOW
- BTOW : 16-bit data combination by byte instruction
- Instruction Input: BTOW
- [Operand1] Source data
- Start number of soft components that store the data to be combined byte by byte

NO.	Operand	Operand Name	Support for Soft Elem	Data Type
1		Source data	D R W Customize	INT [1...n] POINTER
2		Result	D R W Customize	INT [1...n] POINTER
3		Combined data count	D R W K H Customize	INT POINTER

Annotations in the image include:

- A box around the 'Instruction Name' dropdown with the text 'Fill the parameters'.
- A box around the 'OK' button with the text 'Click the <OK> button'.

The 'Toolbox' on the left shows the 'Instruction Set' expanded to 'Basic logic'. The 'Toolbox' on the right shows a list of instructions under 'Data conversion', with 'BTOW(16-bit data combination by byte)' highlighted.

For basic instructions, double click the instruction name in <Toolbox>, an assistant dialog box will pop up, users can find the parameters definition and data type(range), and they can fill the parameters in this view, after that, click <OK> button, the complete instruction with parameters will be added to program

Program Logic

Instruction	Function
LD	Normally open contact
LDI	Normally close contact
AND	Serial connection of NO contact
ANI	Serial connection of NC contact
OR	Parallel connection of NO contact
ORI	Parallel connection of NC contact
LDP	Use of rising edge pulse
LDF	Use of falling edge pulse
ANDP	Serial connection for AND rising edge pulse detection
ANDF	Serial connection for AND falling edge pulse detection
ORP	Parallel connection for OR rising edge pulse detection
ORF	Parallel connection for OR falling edge pulse detection
MEP	Circuit result rising edge detection
MEF	Circuit result falling edge detection

Instruction	Function
OUT	Coil output
SET	Set value for a coil
RST	Reset value for a coil
ZSET	Set value for multi coils
ZRST	Reset value for multi coils
PLS	Rising edge detection
PLF	Falling edge detection
ALT	Alternate output
INV	Operation result inversion

Same with H3U

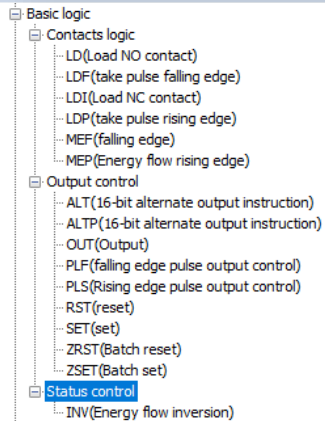

Flow Control

Instruction	Function
CALL	Sub routine call
CJ	Conditional jump
DI	Interrupt Inhibit
EI	Interrupt enable
FOR	Start of a loop
LBL	Label instruction
NEXT	End of a loop
RET	End of step ladder diagram
SSRET	Sub routine conditional return
STL	Start of step ladder diagram
WDT	Monitoring timer reset

- [-] Flow control
 - ... CALL(Subroutine call)
 - ... CJ(Conditional jump)
 - ... DI(Interrupt inhibit)
 - ... EI(Interrupt enable)
 - ... FOR(Start of a loop)
 - ... LBL(Lable instruction)
 - ... NEXT(End of a loop)
 - ... RET(End of step ladder diagram)
 - ... SSRET(Subroutine conditional return)
 - ... STL(Start of step ladder diagram)
 - ... WDT(Monitoring timer reset)

Same with H3U

Instruction	# or *
AND#	=, >, <, <>, >=, <=
LD#	=, >, <, <>, >=, <=
OR#	=, >, <, <>, >=, <=
FLDD#	=, >, <, <>, >=, <=
FANDD#	=, >, <, <>, >=, <=
FORD#	=, >, <, <>, >=, <=
LDZ#	=, >, <, <>, >=, <=
ANDZ#	=, >, <, <>, >=, <=
ORZ#	=, >, <, <>, >=, <=
LD*	&, , ^
AND*	&, , ^
OR*	&, , ^

operator	Description
=	Equal to
>	Greater than
<	Less than
<>	Not equal to
>=	Greater than or equal to
<=	Less than or equal to
&	Logic AND operation
	Logic OR operation
^	Logic XOR operation

Same with H3U

```

Contacts load
AND&(16-bit AND AND instruction)
AND<(16-bit AND contact comparison LT instruction)
AND<=(16-bit AND contact comparison LE instruction)
AND<>(16-bit AND contact comparison NE instruction)
AND=(16-bit AND contact comparison EQ instruction)
AND>(16-bit AND contact comparison GT instruction)
AND>=(16-bit AND contact comparison GE instruction)
AND&&(32-bit AND AND instruction)
ANDD<(32-bit AND contact comparison LT instruction)
ANDD<=(32-bit AND contact comparison LE instruction)
ANDD<>(32-bit AND contact comparison NE instruction)
ANDD=(32-bit AND contact comparison EQ instruction)
ANDD>(32-bit AND contact comparison GT instruction)
ANDD>=(32-bit AND contact comparison GE instruction)
ANDDZ<(32-bit absolute value < compared state contact in
ANDDZ<=(32-bit absolute value < = compared state conta
ANDDZ<>(32-bit absolute value < > compared state conta
ANDDZ=(32-bit absolute value = compared state contact in
ANDDZ>(32-bit absolute value > compared state contact in
ANDDZ>=(32-bit absolute value > = compared state conta
ANDD~(32-bit AND XOR instruction)
ANDD|(32-bit AND OR instruction)
ANDZ<(16-bit absolute value < compared state contact ins
ANDZ<=(16-bit absolute value < = compared state contact
ANDZ<>(16-bit absolute value < > compared state contact
  
```

Data Computation

Arithmetic	Function
(D)ADD(P)	Integer add function
(D)SUB(P)	Integer Subtraction function
(D)MUL(P)	Integer Multiplication function
(D)DIV(P)	Integer Division function
(D)MOD(P)	Integer Mod function(get remainder)
(D)EADD(P)	Float add function
(D)ESUB(P)	Float subtraction function
(D)EMUL(P)	Float multiplication function
(D)EDIV(P)	Float division function
(D)INC(P)	Add by 1
(D)DEC(P)	Subtract by 1

Data Logic Operation	Function
(D)WAND(P)	Word logic AND operation
(D)WOR(P)	Word logic OR operation
(D)WXOR(P)	Word logic XOR operation
(D)NEG(P)	Word Inverter operation
(D)ENEG(P)	Float inverter operation(sign bit inverter)

Bit of Word Operation	Function
(D)BLD	Word bit normally open contact
(D)BLDI	Word bit normally close contact
(D)BAND	Word bit NO serial connection
(D)BANDI	Word bit NC serial connection
(D)BOR	Word bit logic OR operation(NO)
(D)BORI	Word bit logic OR operation(NC)
(D)BOU	Word bit output
(D)BSET	Word bit set value
(D)BRST	Word bit reset value

D means 32 bit instruction (without D means 16 bit instruction)
P means instruction works on rising edge
***Most instructions support add D prefix and/or P suffix, some of them only support 1/or 2 format of them , details please check in <Toolbox> of Autoshop.**

Data Computation

Trigonometric	Function
(D)SIN(P)	Sine
(D)TAN(P)	Tangent
(D)COS(P)	Cosine
(D)ASIN(P)	Anti sine
(D)ACOS(P)	Anti cosine
(D)ATAN(P)	Anti tangent
(D)RAD(P)	Convert angle to radians
(D)DEG(P)	Convert radians to angle
(D)SINH(P)	Hyperbolic sine
(D)COSH(P)	Hyperbolic cosine
(D)TANH(P)	Hyperbolic tangent

Table Operation	Function
(D)WSUM(P)	Calculate summary value
(D)MEAN(P)	Calculate mean value
(D)LIMIT(P)	Output limit control
(D)BZAND(P)	Output dead zone control
(D)ZONE(P)	Output offset control
(D)SCL(P)	Coordinates according to given curve
(D)SCL2(P)	Coordinates according to given curve
Exponent arithmetic	Function
(D)EXP(P)	Exponential operation base on e(2.71828)
(D)LOG(P)	Logarithm operation base on 10
(D)LOGE(P)	Logarithm operation base on e(2.71828)
(D)ESQR(P)	Square root of binary float data
(D)SQR(P)	Square root operation
(D)POW(P)	Pow operation

D means 32 bit instruction (without D means 16 bit instruction)
P means instruction works on rising edge
***Most instructions support add D prefix and/or P suffix, some of them only support 1/or 2 format of them , details please check in <Toolbox> of Autoshop.**

Data Processing

Data Conversion	Function
(D)INT(P)	Float to integer
(D)BCD(P)	BIN data to BCD data
(D)BIN(P)	BCD data to BIN data
(D)FLT(P)	BIN integer to BIN float
(D)EBCD(P)	BIN float to DEC float
(D)EBIN(P)	DEC float to BIN float
(D)DABIN(P)	DEC ASCII to BIN
(D)BINDA(P)	BIN to DEC ASCII
(D)WTOB(P)	Word divided by byte
(D)BITW(P)	Bit element assignment word element
(D)BTOW(P)	Combination of byte to word

Data Conversion	Function
(D)WBIT(P)	Word element assignment bit element
(D)WTODW(P)	16 bit word to 32 bit double word
(D)DWTOW(P)	32 bit double word to 16 bit word
(D)MCPY(P)	Data Copy(memory copy)
(D)MSET(P)	Data set(memory set)
(D)UNI(P)	Combination of lower 4-bit of continuous 16 bit data
(D)DIS(P)	Word divided by 4-bit
(D)ASCI(P)	HEX to ASCII
(D)HEX(P)	ASCII to HEX

D means 32 bit instruction (without D means 16 bit instruction)
P means instruction works on rising edge
***Most instructions support add D prefix and/or P suffix, some of them only support 1/or 2 format of them , details please check in <Toolbox> of Autoshop.**

Data Processing

Data Transmission	Function
(D)MOV(P)	Data assignment
(D)EMOV(P)	BIN float data assignment
(D)BMOV(P)	Data batch assignment
(D)SMOV(P)	Bit data transmission
(D)FMOV(P)	Data assignment to multi registers
(D)CML(P)	Data inverter via bit then transmission
(D)CMP(P)	Data comparison output
(D)ECMP(P)	Float data comparison output
(D)ZCP(P)	Regional comparison
(D)EZCP(P)	Float data regional comparison

Table Operation	Function
(D)SER(P)	Data search
(D)FDEL(P)	Delete table data
(D)FINS(P)	Insert data to table
(D)POP(P)	Read the latest data of SFWR

D means 32 bit instruction (without D means 16 bit instruction)

P means instruction works on rising edge

***Most instructions support add D prefix and/or P suffix, some of them only support 1/or 2 format of them , details please check in <Toolbox> of Autoshop.**

Data Processing

Data Shift	Function
(D)ROR(P)	Data right shift by bit
(D)ROL(P)	Data left shift by bit
(D)RCR(P)	Data right shift by bit(with carry flag M8022)
(D)RCL(P)	Data left shift by bit(with carry flag M8022)
(D)SFTR(P)	Data right shift by multi bits(high bits replaced by specified data)
(D)SFTL(P)	Data left shift by multi bits(low bits replaced by specified data)
(D)WSFR(P)	Data right shift by multi words(high words replaced by specified data)
(D)WSFL(P)	Data left shift by multi words(low words replaced by specified data)
(D)SFWR(P)	FIFO write data
(DSFRD(P)	FIFO read data

Data Shift	Function
(D)SFR(P)	Data right shift by bit(with carry flag M8022, high bit(s) discarded)
(D)SFL(P)	Data left shift(with carry flag M8022,low bit(s) discarded)
Others	Function
(D)SWAP(P)	High byte and low byte exchange
(D)BON(P)	Word data bit status to control other bit status
(D)SUM(P)	Calculate quantities of '1' in a BIN data
(D)RAND(P)	Generate rand data within a range
(D)XCH(P)	Word registers data exchange
(D)ABS(P)	Integer absolute value calculation
(D)EABS(P)	Float absolute value calculation
(D)EFMOV(P)	Multi float data transmission
(D)CCD(P)	Summation check
(DCRC(P)	Cyclical redundancy check
(D)LRC(P)	Longitudinal redundancy check

D means 32 bit instruction (without D means 16 bit instruction)
P means instruction works on rising edge
***Most instructions support add D prefix and/or P suffix, some of them only support 1/or 2 format of them , details please check in <Toolbox> of Autoshop.**

Matrix

Data Shift	Function
(D)BK+(P)	Data block add operation
(D)BK-(P)	Data block subtract operation
(D)MAND(P)	Matrix AND operation
(D)MOR(P)	Matrix OR operation
(D)MXNR(P)	Matrix XNR operation
(D)MXOR(P)	Matrix XOR operation
(D)MINV(P)	Matrix INV operation
(D)BLCMP#(P)	Matrix comparison(#: =, >, <, <>, <=, >=)

D means 32 bit instruction (without D means 16 bit instruction)
P means instruction works on rising edge
***Most instructions support add D prefix and/or P suffix, some of them only support 1/or 2 format of them , details please check in <Toolbox> of Autoshop.**

String Processing

String Processing	Function
(D)STR(P)	Integer convert to string(ASCII)
(D)STRMOV(P)	Assignment string directly
(D)VAL(P)	String(ASCII) convert to integer
(D)ESTR(P)	Float convert to string(ASCII)
(D)EVAL(P)	String(ASCII) to float
(D)\$ADD(P)	Contact string
(D)LEN(P)	Calculate bytes of string
(D)INSTR(P)	Retrieve given string in an existed string
(D)RIGHT(P)	Take out given length string from an existed string (from right side)
(D)LEFT(P)	Take out given length string from an existed string (from left side)

String Processing	Function
(D)MIDW(P)	Replace specified string with specified string
(D)MIDR(P)	Take out given length string form an existed string (from any position)
(D)\$MOV(P)	String transmission

D means 32 bit instruction (without D means 16 bit instruction)
P means instruction works on rising edge
***Most instructions support add D prefix and/or P suffix, some of them only support 1/or 2 format of them , details please check in <Toolbox> of Autoshop.**

Clock

String Processing	Function
(D)TCMP(P)	Compared dedicated time with RTC
(D)TZCP(P)	Compared dedicated time range with RTC
(D)TADD(P)	Time add operation
(D)TSUB(P)	Time subtract operation
(D)HTOS(P)	Convert 'hh:mm:ss' to second format
(D)STOH(P)	Convert second format to 'hh:mm:ss'
(D)TRD(P)	Read RTC(year/month/day/hour/minute/second/ week)
(D)TWR(P)	Refresh RTC with given time
(D)HOUR(P)	Time record, while up to pre-set time, output valid

D means 32 bit instruction (without D means 16 bit instruction)
P means instruction works on rising edge
***Most instructions support add D prefix and/or P suffix, some of them only support 1/or 2 format of them , details please check in <Toolbox> of Autoshop.**

String Processing	Function
(D)TPR(P)	Normal timer
(D)TONR(P)	On delay timer
(D)TOFR(P)	Off delay timer
(D)TACR(P)	Time accumulation timer

D means 32 bit instruction (without D means 16 bit instruction)

P means instruction works on rising edge

***Most instructions support add D prefix and/or P suffix, some of them only support 1/or 2 format of them , details please check in <Toolbox> of Autoshop.**

Pointer

String Processing	Function
(D)PTGET(P)	Get the address of pointer
(D)PTINC(P)	Increase pointer address by 1
(D)PTDEC(P)	Decrease pointer address by 1
(D)PTADD(P)	Add pointer address by set offset
(D)PTSUB(P)	Decrease pointer address by set offset
(D)PTSET(P)	Point to set length variable by bit
(D)PTMOV(P)	Pointer variable assignment
(D)PT#(P)	PT variable address comparison(#: >, >=, <>, <, <=)

D means 32 bit instruction (without D means 16 bit instruction)

P means instruction works on rising edge

***Most instructions support add D prefix and/or P suffix, some of them only support 1/or 2 format of them , details please check in <Toolbox> of Autoshop.**

Communication

String Processing	Function
SerialSR	Serial free protocol instruction
TCP_Listen	TCP socket listen
TCP_Accept	TCP socket accept
TCP_Connect	TCP socket connect
TCP_Close	TCP socket close
TCP_Send	TCP socket send
TCP_Receive	TCP socket receive
UDP_Bind	UDP socket bind
UDP_Receive	UDP socket receive
UDP_Send	UDP socket send

String Processing	Function
ETC_ReadParameter_CoE	SDO read via CoE
ETC_WriteParameter_CoE	SDO write via CoE

➤ **SerialSR**

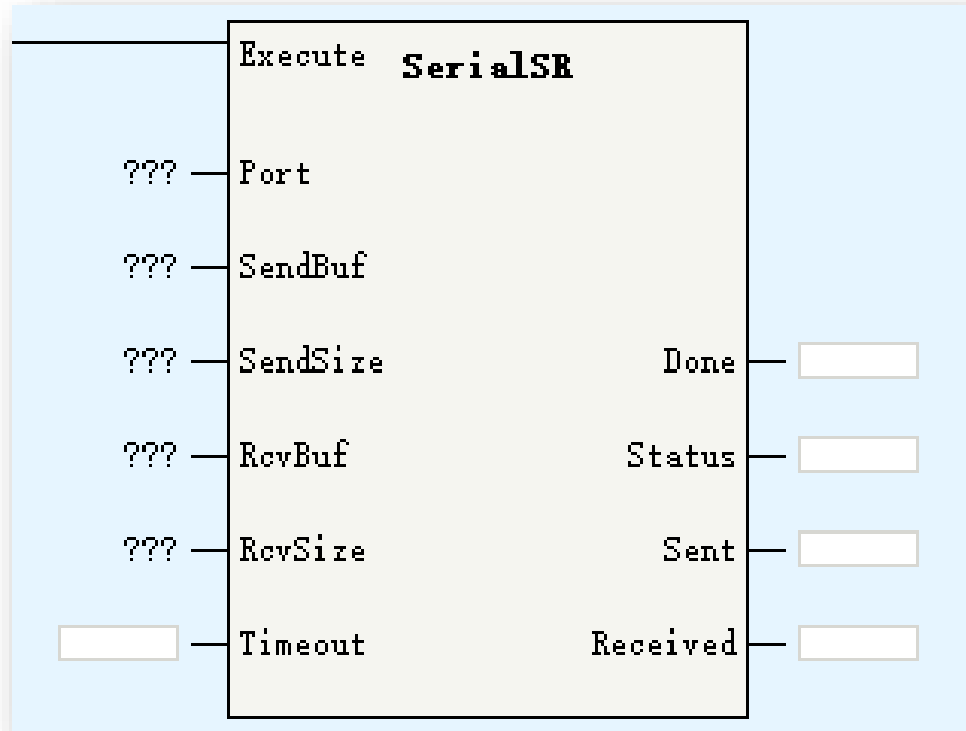

Parameters	Description
Port	Port number
SendBuf	Send data buffer area
SendSize	Send byte size
RcvBuf	Receive data buffer area
RcvSize	Receive byte size
Timeout	Receive timeout
Done	Communication done
Status	Command Status
Sent	Sent data size(Byte)
Received	Receive data size(Byte)

SerialSR is used for serial free communication.

➤ SerialSR

Port: H5U only have 1 serial port, default as 0, no need to modify.

SendBuf: array type data, specified the send data store area

SendSize: specified send data size

RcvBuf: array type data, specified the receive data store area

RcvSize: specified receive size data

Timeout: limit for summary of send time and receive time, if there is no feedback data frame within timeout, the <Status> will display the abnormal status

Done: communication complete

Status: 0-empty, 1-reserved, 2-send, 3-receive 16-Done, 32-send abnormal, 48-receive abnormal, 64-Other abnormal

Sent: sent data size

Received: received data size

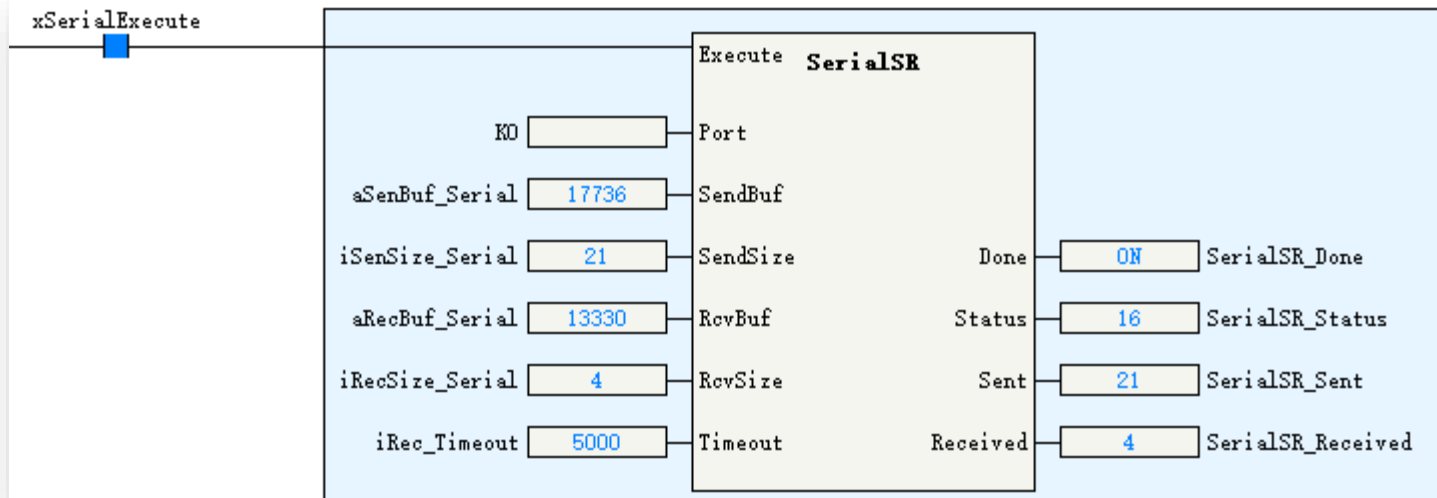

➤ SerialSR

The sequence diagram:

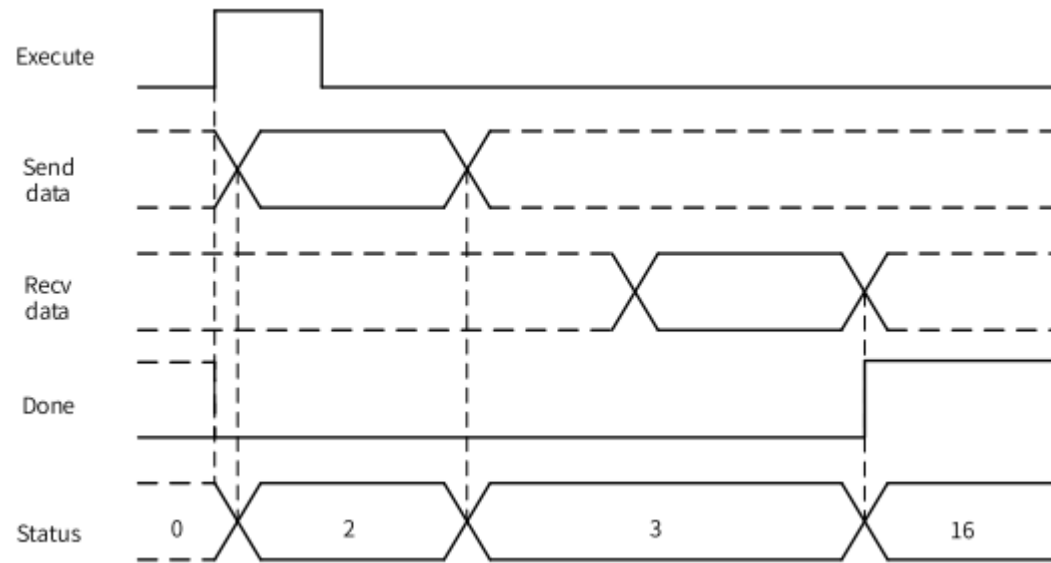

➤ Socket Communication

Socket is the port used for dual direction communication. H5U support TCP socket(connection oriented) and UDP socket (non connection oriented), the communication logic show as below:

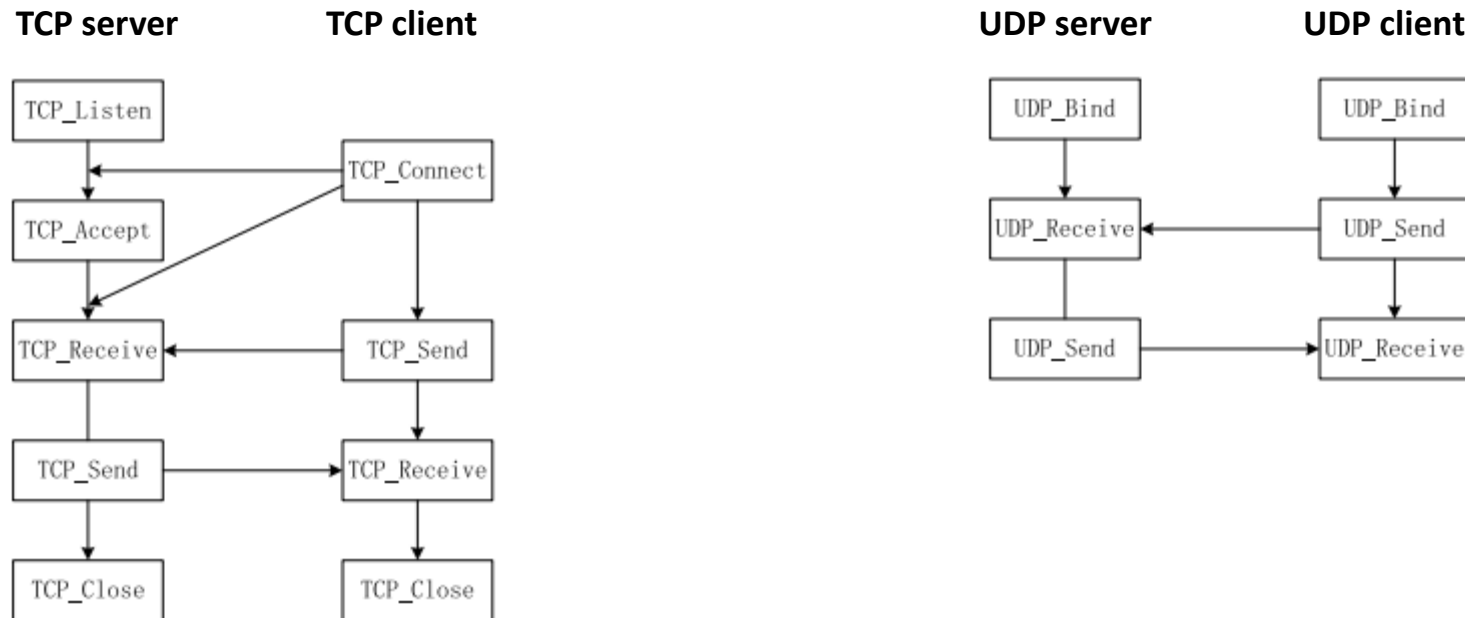

TCP is transmission control protocol, UDP is user data protocol, they are both the transmission layer protocol of OSI communication prototype.

The difference is TCP protocol need built a connection before communication but UDP no need built the connection. TCP is reliable communication on connection mechanism normally used in the scenario that need keep the data accuracy. UDP is not reliable communication, which means UDP no need concern about the content of data message and no demand for check if receiver already got the data, it has simple data process and fast speed, normally used in the scenario that need the real-time ability.

➤ TCP_Listen

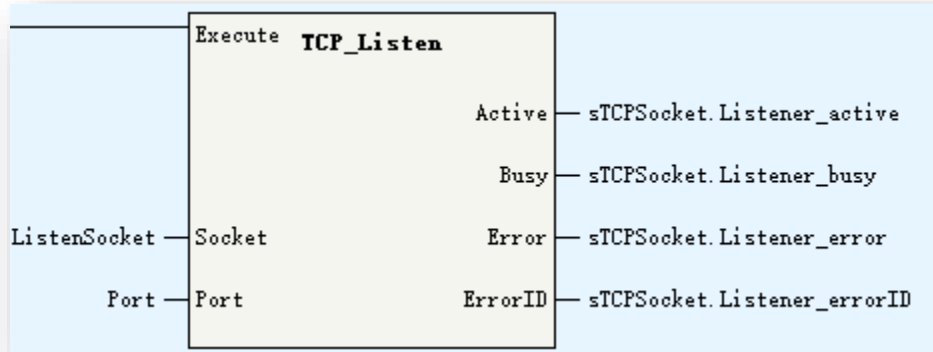

Parameters	Description
Socket	Socket. Currently don't support _sSocket data type, users can use an INT[20] as socket, take note this parameters is an input/output type data
Port	The listen port of H5U *Don't use 23/12939/12940/502, this port used by system
Active	Socket active status

TCP server have to listen the specified port to wait the connection request from client, while the server receive the connection request, need use TCP_Accept to built the connection with client.

➤ TCP_Accept

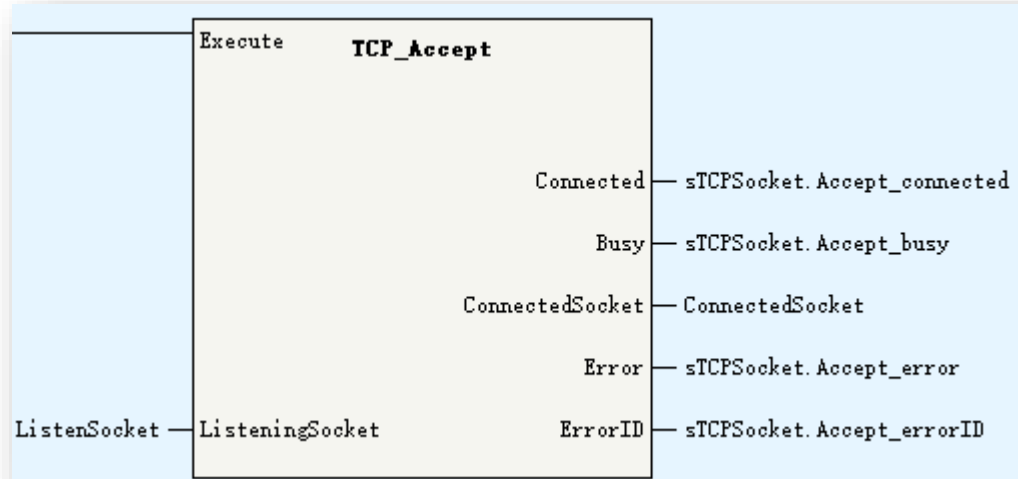

Parameters	Description
ListeningSocket	Socket. Currently don't support _sSocket data type, users can use an INT[20] as socket, take note this parameters is an input/output type data
Connected	The listen port of H5U *Don't use 23/12939/12940/502, this port used by system
ConnectedSocket	Connected Socket. Data transmission will base on this socket

TCP_Accept used to accept the connection request from client and build a connection socket while controller used as TCP socket server, the data transmission will base on this <ConnectedSocket>.

➤ TCP_Connected

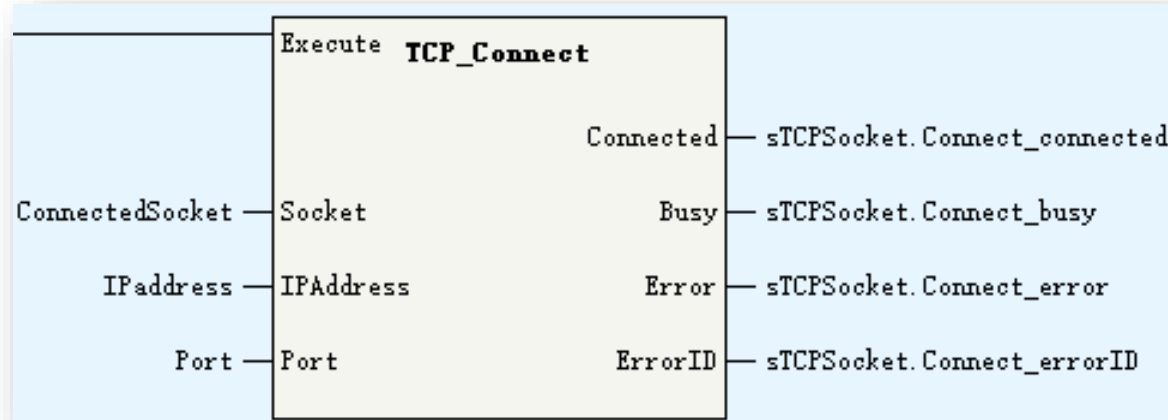

Parameters	Description
Socket	Socket. Currently don't support _sSocket data type, users can use an INT[20] as socket, take note this parameters is an input/output type data
IPAddress	Server IP address
Port	Connected port
Connected	Connected

TCP_Connect used to connect the specified port of server while controller used as TCP socket client, if the connection built, <Connected> will be valid. After that, user can use TCP_Send and TCP_Receive to send or receive data. Take note, while TCP client send connection request to server, and there is no response from server after 127 second, the connection operation is failed.

Communication

➤ TCP_Close

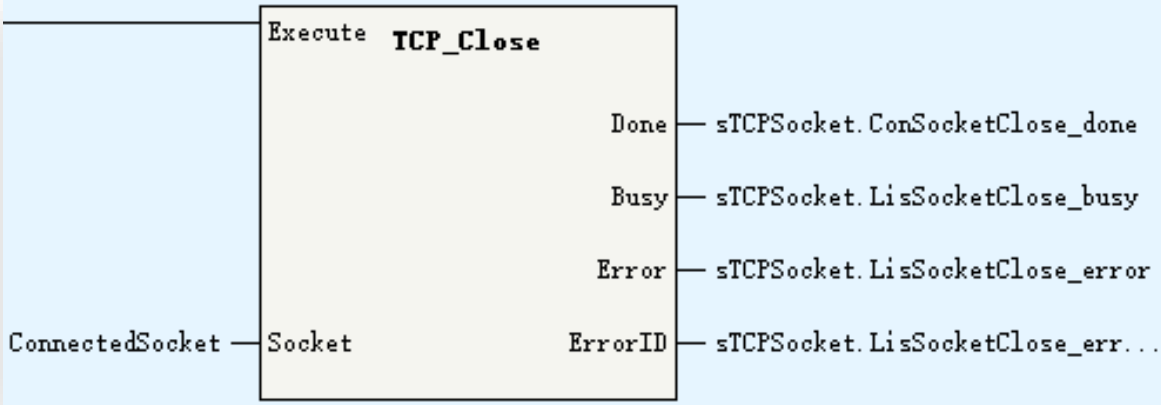

Parameters	Description
Socket	Socket. Currently don't support <code>_sSocket</code> data type, users can use an <code>INT[20]</code> as socket, take note this parameters is an input/output type data

TCP_Close is used to close the connection or listening after communication done.

Communication

➤ TCP_Send

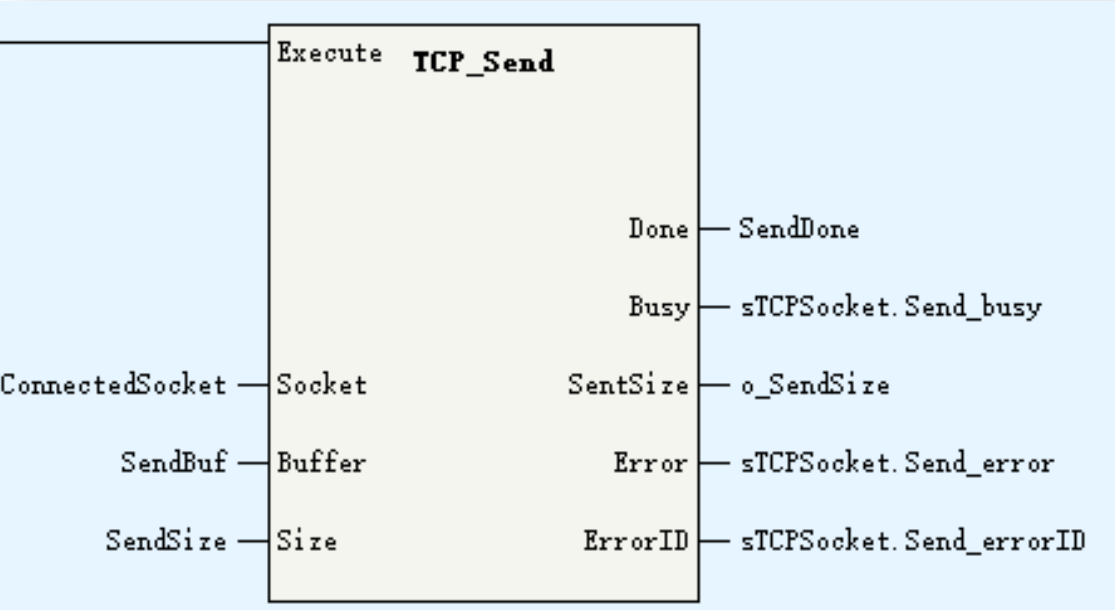

Parameters	Description
Socket	Socket. Currently don't support _sSocket data type, users can use an INT[20] as socket, take note this parameters is an input/output type data
Buffer	Send buffer
Size	Receive data size
SentSize	Sent data size

TCP_Send used to send data to server/client while the connection is built. Take note the <Size> have to be less than <Buffer> size.

Communication

➤ TCP_Receive

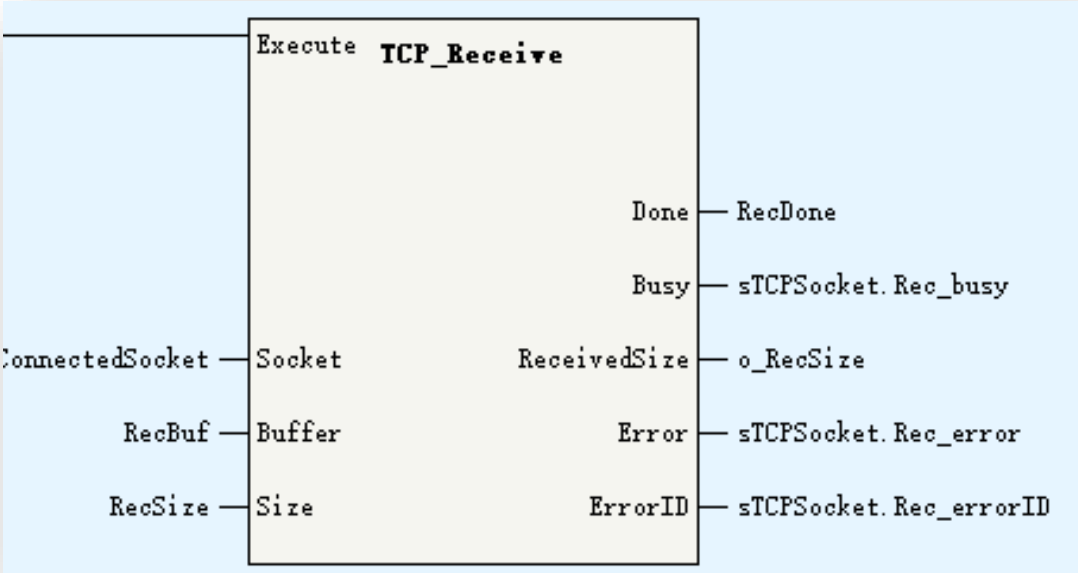

Parameters	Description
Socket	Socket. Currently don't support _sSocket data type, users can use an INT[20] as socket, take note this parameters is an input/output type data
Buffer	Receive buffer
Size	Receive data size
ReceivedSize	Received data size

TCP_Receive used to receive data from server/client while the connection is built. Take note the <Size> have to be less than <Buffer> size.

➤ TCP socket test

The image shows a PLC ladder logic program on the left and a TCP socket test application window on the right.

PLC Ladder Logic:

- Network M8000: Program run flag (sag) is ON, stop flag (stop) is OFF.
- Network Tsocket01: The **FB_TCPsocket** function block is enabled.
- Parameters for **FB_TCPsocket**:
 - Enable: ON
 - sTCP: (Server/Client)
 - ServerClient: (Server/Client)
 - Port: K1234
 - IPAddress: HCOA80158
 - RecBuf: aRecBuf_TCP
 - RecSize: IRecSize_TCP (50)
 - SendBuf: aSenBuf_TCP
 - SendSize: iSenSize_TCP (50)
 - Cycle: K1000
 - bSend: ON
 - bReceive: ON
- Status Indicators:
 - Connected: ON
 - o_RecSize: 9
 - o_SendSize: 50
 - RecDone: ON
 - SendDone: ON
 - Error: OFF

TCP Socket Test Application (Form1):

- Mode: TCP Client (selected), TCP Server, UDP
- Connection Panel:
 - IP: 192.168.1.88
 - Port: 1234
 - Buttons: Listen, Close
- Communication Panel:
 - Send: RECEIVED!
 - Receive: HELLO INOVANCE TCP
 - Buttons: Start (green), Stop, Send

For more details refer the application example.

➤ UDP_Bind

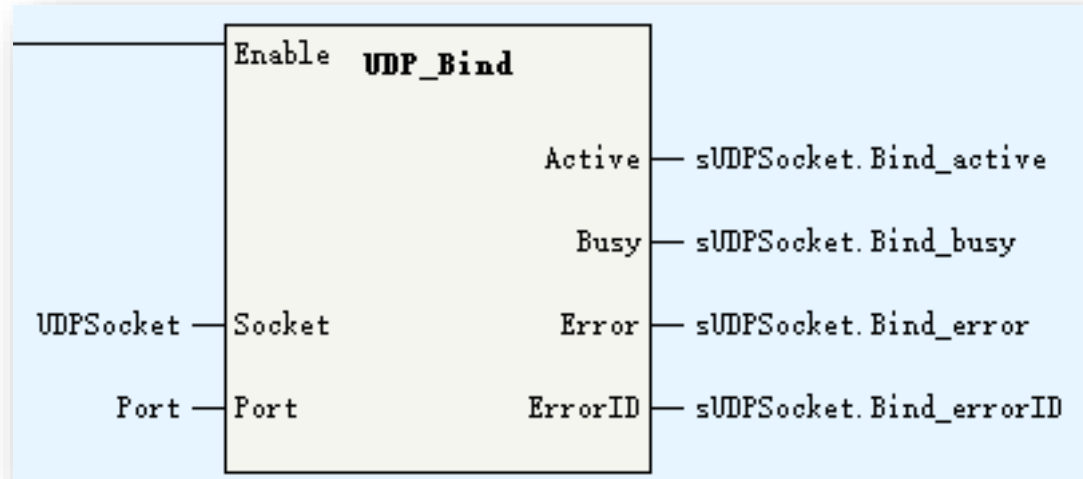

Parameters	Description
Socket	Socket. Currently don't support <code>_sSocket</code> data type, users can use an <code>INT[20]</code> as socket, take note this parameters is an input/output type data
Port	UDP port

UDP_Bind is used to bind UDP socket to local port.

Communication

➤ **UDP_Receive**

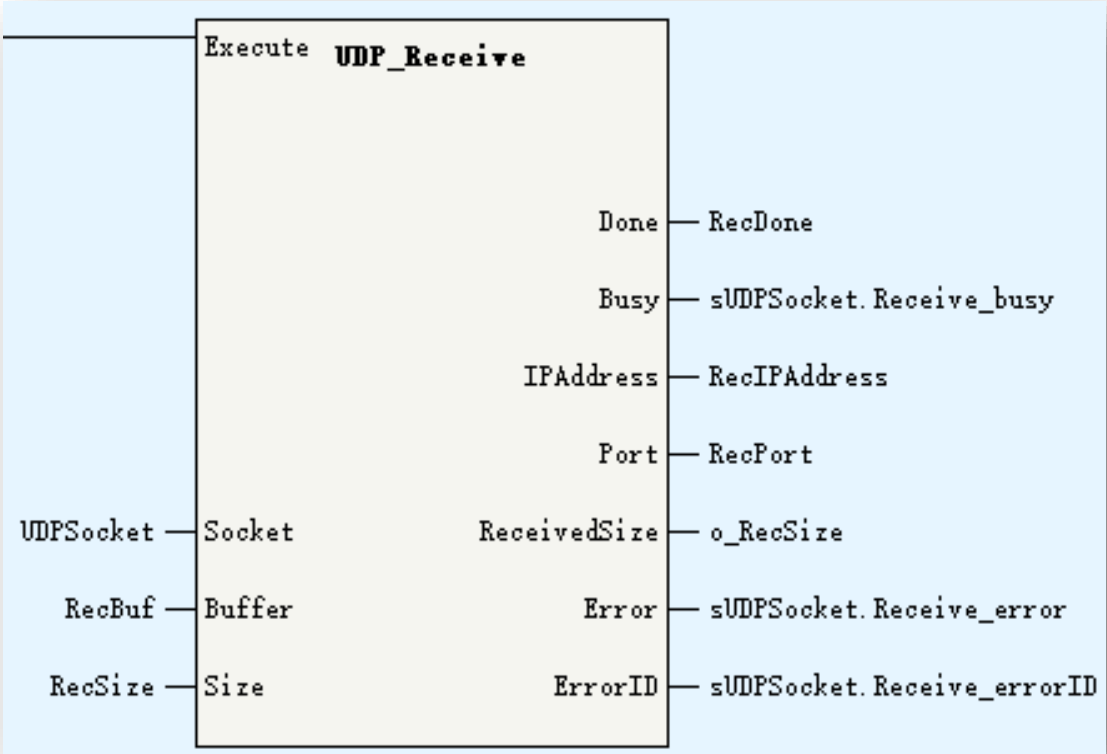

Parameters	Description
Socket	Socket. Currently don't support _sSocket data type, users can use an INT[20] as socket, take note this parameters is an input/output type data
Buffer	Receive buffer
Size	Receive size
IPAddress	IP address
Port	UDP port
ReceivedSize	Received size

UDP_Receive used to receive data.
 Take note the <Size> have to be less than <Buffer> size.

➤ **UDP_Send**

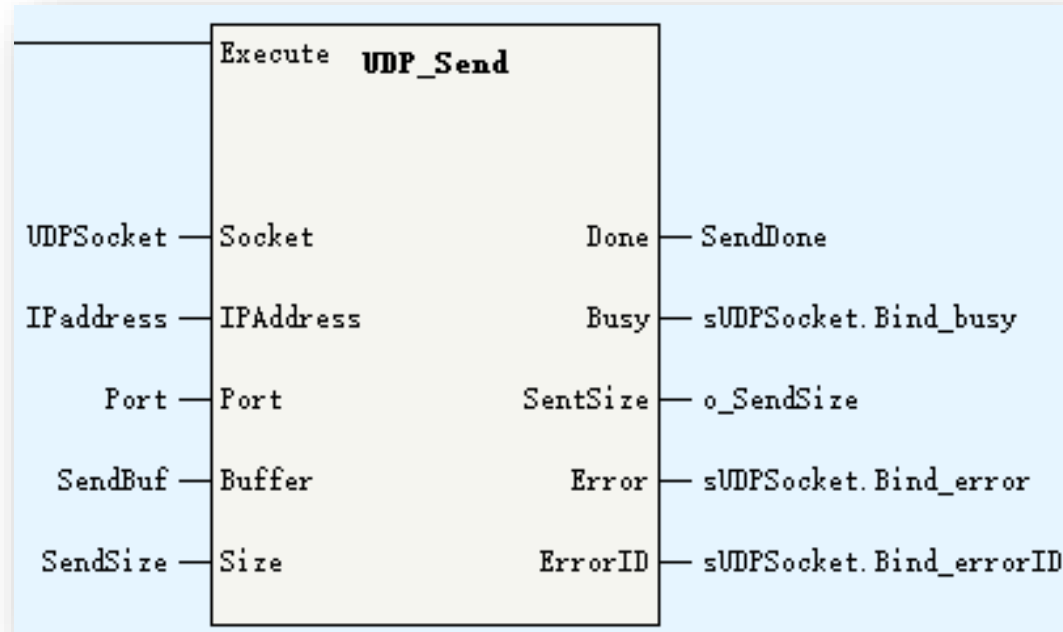

Parameters	Description
Socket	Socket. Currently don't support _sSocket data type, users can use an INT[20] as socket, take note this parameters is an input/output type data
IPAddress	IP address
Port	UDP port
Buffer	Send buffer
Size	Send size
SentSize	Sent data size

UDP_Send used to send data.
 Take note the <Size> have to be less than <Buffer> size.

Communication

➤ UDP socket test

The screenshot displays the SIMATIC Manager interface for a UDP socket test. On the left, a tree view shows the project structure with '192.168.1.88[4321]' selected under 'UDP Client'. The main window is divided into several sections:

- Socket状态 (Socket Status):** Shows '对方IP:192.168.1.88' (Remote IP: 192.168.1.88).
- 数据接收及提示窗口 (Data Reception and Prompt Window):** Contains the log:

```
16:04:08 收到数据: HELLO INOVANCE UDP
16:04:20 发送数据: RECEIVED![10次]
```
- 数据发送窗口(文本模式) (Data Transmission Window (Text Mode)):** Currently empty.
- 显示十六进制值 (Show Hexadecimal Values):** A checkbox that is currently unchecked.
- Project Manager:** Shows the ladder logic network 'M8000'.
- Ussocket01:** A function block 'FB_UDPSocket' with the following parameters:
 - Enable: ON
 - sUDPSocket: (empty)
 - Port: K4321
 - IPAddress: HCOA80101
 - RecBuf: aRecBuf_UDP
 - RecSize: iRecSize_UDP (50)
 - SendBuf: aSendBuf_UDP
 - SendSize: iSenSize_UDP (50)
 - Cycle: 0
 - bSend: ON
 - bReceive: ON
 - o_RecSize: 9
 - o_SendSize: 50
 - RecDone: ON
 - SendDone: ON
 - RecIPAddress: -1062731519
 - RecPort: 4321
 - Error: OFF

For more details refer the application example.

Communication

➤ ETC_ReadParameter_CoE

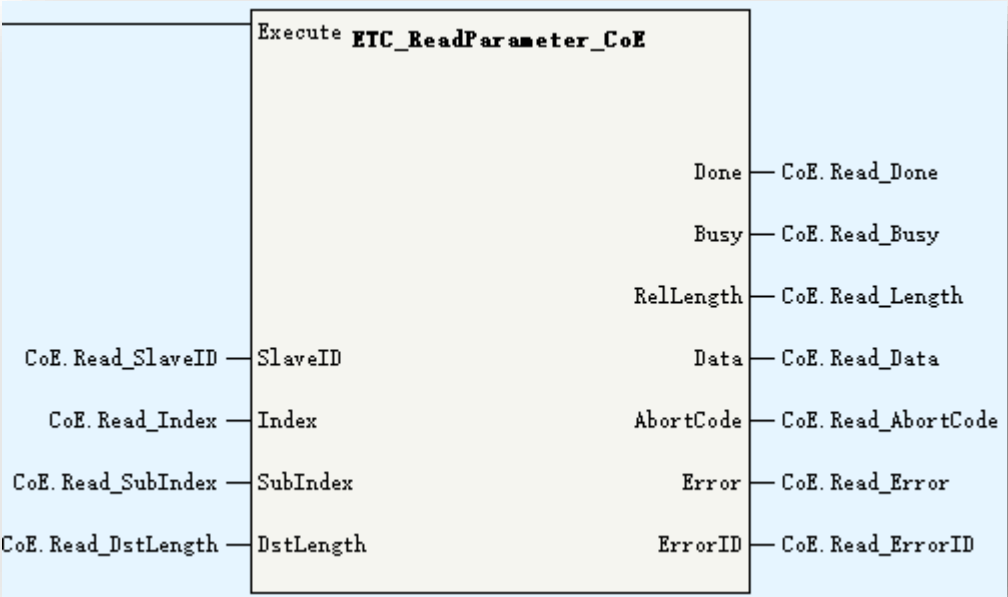

Parameters	Description
SlaveID	Slave sequence address
Index	Object dictionary index
SubIndex	Object dictionary sub index
DstLength	Read length(byte)
RelLength	Actual read length
Data	Read data
AbortCode	Abort code while failed to read slave

ETC_ReadParameter_CoE is used to read slave parameters via CoE.
 <SlaveID> specified the slave,
 <Index> and <SubIndex> used to specified the object dictionary address which wanted read,
 <DstLength> specified the wanted read data length, the unit is byte.

Take note:
 If master is failed to read slave, there will be an <AbortCode>, users can check the [<AbortCode>](#) to find the fault reason.

Communication

➤ ETC_WriteParameter_CoE

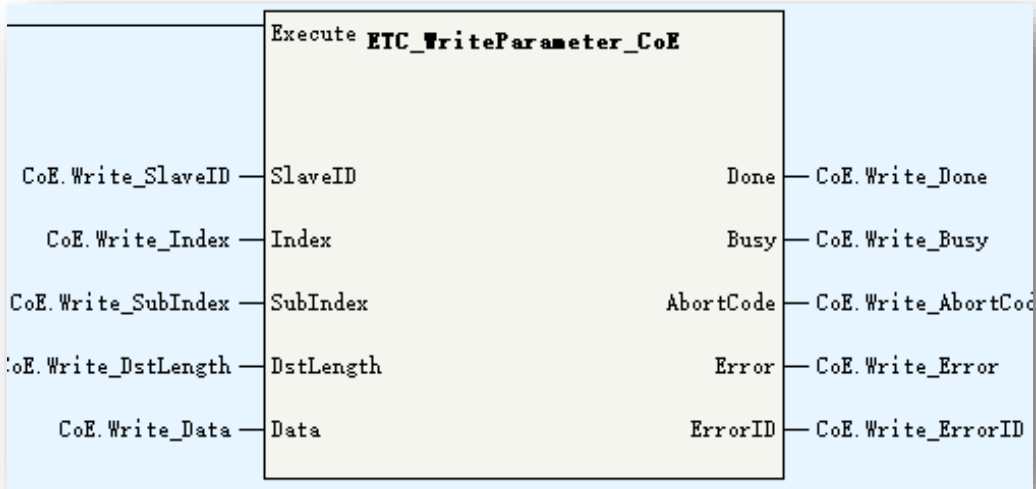

Parameters	Description
SlaveID	Slave sequence address
Index	Object dictionary index
SubIndex	Object dictionary sub index
DstLength	Write length(byte)
Data	Write data
AbortCode	Abort code while failed to write slave

ETC_WriteParameter_CoE is used to write slave parameters via CoE.

<SlaveID> specified the slave,
 <Index> and <SubIndex> used to specified the object dictionary address which wanted read,
 <DstLength> specified the wanted write data length, the unit is byte.

Take note:

If master is failed to write slave, there will be an <AbortCode>, users can check the [<AbortCode>](#) to find the fault reason.

Communication

➤ SDO abort code

Abort code	Description
0503 0000 _h	Toggle bit not alternated.
0504 0000 _h	SDO protocol timed out.
0504 0001 _h	Client/server command specifier not valid or unknown.
0504 0002 _h	Invalid block size (block mode only).
0504 0003 _h	Invalid sequence number (block mode only).
0504 0004 _h	CRC error (block mode only).
0504 0005 _h	Out of memory.
0601 0000 _h	Unsupported access to an object.
0601 0001 _h	Attempt to read a write only object.
0601 0002 _h	Attempt to write a read only object.
0602 0000 _h	Object does not exist in the object dictionary.
0604 0041 _h	Object cannot be mapped to the PDO.
0604 0042 _h	The number and length of the objects to be mapped would exceed PDO length.
0604 0043 _h	General parameter incompatibility reason.
0604 0047 _h	General internal incompatibility in the device.
0606 0000 _h	Access failed due to an hardware error.
0607 0010 _h	Data type does not match, length of service parameter does not match
0607 0012 _h	Data type does not match, length of service parameter too high
0607 0013 _h	Data type does not match, length of service parameter too low
0609 0011 _h	Sub-index does not exist.

Abort code	Description
0609 0030 _h	Invalid value for parameter (download only).
0609 0031 _h	Value of parameter written too high (download only).
0609 0032 _h	Value of parameter written too low (download only).
0609 0036 _h	Maximum value is less than minimum value.
060A 0023 _h	Resource not available: SDO connection
0800 0000 _h	General error
0800 0020 _h	Data cannot be transferred or stored to the application.
0800 0021 _h	Data cannot be transferred or stored to the application because of local control.
0800 0022 _h	Data cannot be transferred or stored to the application because of the present device state.
0800 0023 _h	Object dictionary dynamic generation fails or no object dictionary is present (e.g. object dictionary is generated from file and generation fails because of a file error).
0800 0024 _h	No data available

➤ ETC_RestartMaster

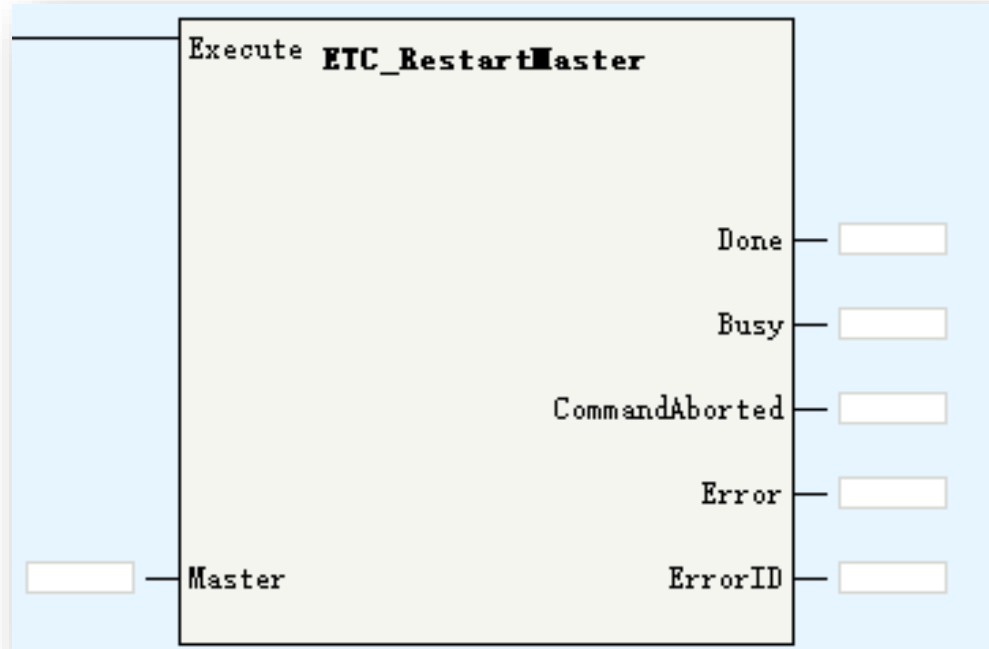

Parameters	Description
Master	EtherCAT master

ETC_RestartMaster is used to restart EtherCAT master.

String Processing	Function
PID	PID instruction

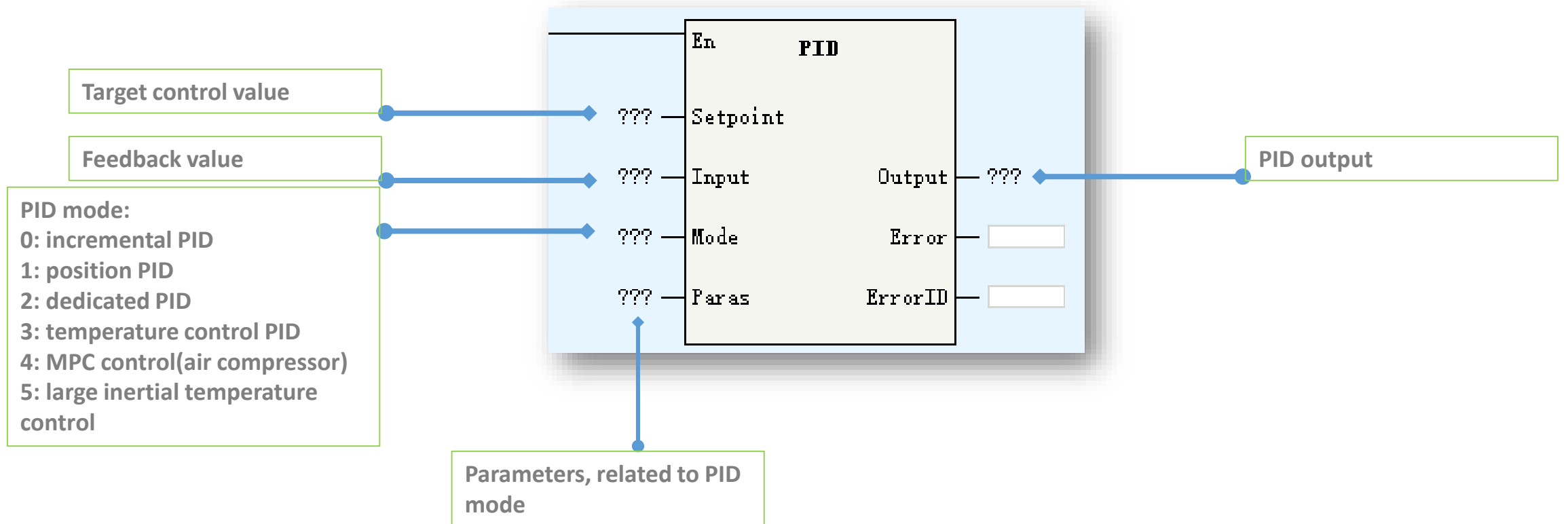

PID-Mode 0: Incremental PID Parameters

Address	Function	Description
S4(start address)	Capture time(TS)	1~32767ms, need over than PLC scan cycle
S4+1	Action direction(ACT)	Bit 0: 0=positive action, 1=negative action Bit 1: 0=input variation alarm invalid, 1=input variation alarm valid Bit2:0=output variation alarm invalid, 1=output variation alarm valid Bit3: reserved Bit4: 0=auto tune invalid, 1=auto tune valid(currently not support) Bit5: output up/down limit, 0=invalid, 1=valid Bit6~15: reserved Be noted: don't let bit5 and bit2 ON at the same time
S4+2	Input filter time(α)	0~99%, 0=no input filter
S4+3	Proportion gain(Kp)	1~32767%
S4+4	Integration time(T1)	0~32767(*100ms), 0=no integration
S4+5	Differentiation gain(KD)	0~100%, 0 = no differentiation
S4+6	Differentiation time	0~32767(*10ms), 0=no differentiation
S4+(7~19)	Internal usage	Clear before first executing PID
While <ACT> Bit1=1, Bit2=1 or Bit5=1, S4+(20~24) will be used, the definition show as below:		
S4+20	Input increase variation alarm value	0~32767, valid while <ACT> Bit1=1
S4+21	Input decrease variation alarm value	0~32767, valid while <ACT> Bit1=1
S4+22	Output increase variation(or up limit) alarm value	0~32767, valid while <ACT> Bit2=1, Bit5=0 /-32768~32767, output up limit while <ACT> bit1=0, bit5=1
S4+23	Output decrease variation(or low limit) alarm value	0~32767, valid while <ACT> Bit2=1, Bit5=0 /-32768~32767, output up limit while <ACT> bit1=0, bit5=1
S4+24	Alarm output	Bit0 input increase variation overflow, Bit1 input decrease variation overflow Bit2 output increase variation overflow, Bit3 output decrease variation overflow
S4+25	Internal usage	--

PID-Mode 1: Position PID Parameters

Address	Function	Description
S4(start address)	Capture time(TS)	1~32767ms, default 10
S4+1	Control mode	0:positive 1:negative
S4+2	Proportion gain(Kp1)	0~32767%
S4+3	Integration gain(Ki1)	0~32767%
S4+4	Differentiation gain(Kd1)	0~32767%
S4+5	Deviation dead zone	0~32767, 0=invalid, while deviation less than set value, recognize deviation as 0
S4+6	Output up limit	-32768~32767
S4+7	Output low limit	-32768~32767
S4+8	Integration up limit	-32768~32767
S4+9	Integration low limit	-32768~32767
S4+10/11	Accumulative integration	32bit float
S4+12	Internal usage	Last time output
S4+13	Kp2	0~32767%
S4+14	Ki2	0~32767%
S4+15	Kd2	0~32767%
S4+16	Gain exchange condition	0: invalid(S4-17~19 not work) 1: according to deviation 2: customized
S4+17	Deviation low limit E1	-32768~32767
S4+18	Deviation up limit E2	-32768~32767
S4+19	Customized gain exchange	-32768~32767
S4+20~26	Internal usage	--

PID-Mode 1: Position PID Parameters

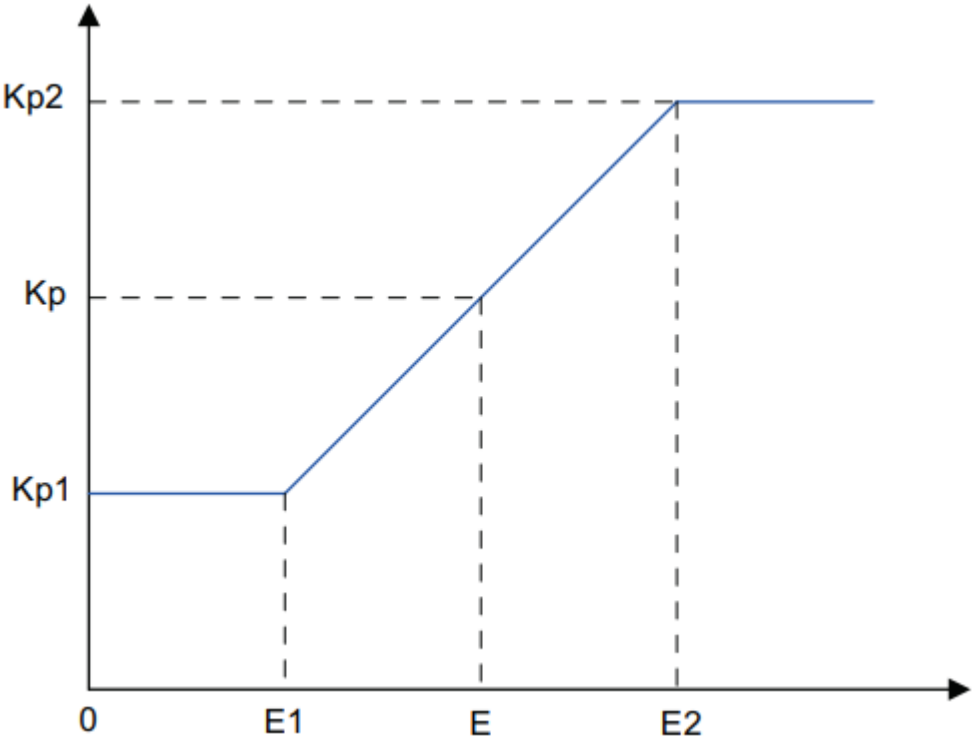

Gain exchange principle(proportion gain as example):

- While $E \leq E1$, $Kp = Kp1$;
- While $E1 < E < E2$, $Kp = Kp1 + (Kp2 - Kp1) * (E - E1) / (E2 - E1)$;
- While $E \geq E2$, $Kp = Kp2$;

*While $S4+16=0$, no gain exchange
 $S4+16=1$, $E = |Sv - Pv|$
 $S4+16=2$, $E = S4+19$

Par	Description
Kp1	S4+2
Kp2	S4+13
E1	S4+17
E2	S4+18
E	Exchange reference

PID-Mode 3: Temperature control PID Parameters

[Back to Contents](#)

Address	Function	Description
S4(start address)	Capture time(TS)	1~32767ms, need over than PLC scan cycle
S4+1	Control mode	Bit0: 0:positive 1:negative Bit4: 0=auto tune invalid 1= auto tune, reset after auto tune done
S4+2	Auto tune mode	0: common mode, appropriate overshoot 1: slow mode, small overshoot, but slow temperature increment 2: fast mode, fast temperature increment, but large overshoot
S4+3	Proportion band	1~32767, proportion band lower, proportion effect stronger. Auto tune will generate proportion band
S4+4	Integration time	1~32767, 0=no integration, auto tune will generate integration time
S4+5	Differentiation time	1~32767, 0=no differentiation, auto tune will generate differentiation
S4+6	Output up limit	-32768~32767
S4+7	Output low limit	-32768~32767
S4+8	Reserved	--
S4+9	Proportion output	Current proportion calculation output
S4+10	Integration output	Current integration proportion calculation output
S4+11	Differentiation output	Current differentiation calculation output
S4+12~19	Internal usage	--

Compared with H3U, H5U have different command format(H3U using ladder whereas H5U using function block), except this, H5U parameters setting almost same as H3U.

Motion Control(EtherCAT & Pulse Output)

[Back to Contents](#)

Basic Motion Control	Function
MC_Power	Axis enable control
MC_Reset	Axis error reset
MC_ReadStatus	Read axis status
MC_ReadAxisError	Read axis error
MC_ReadDigitalInput	Read drive digital input
MC_ReadActualPosition	Read actual position
MC_ReadActualVelocity	Read actual velocity
MC_ReadActualTorque	Read actual torque
MC_SetPosition	Set axis position
MC_TouchProbe	Touch probe function
MC_MoveRelative	Axis position relatively
MC_MoveAbsolute	Axis position absolutely
MC_MoveVelocity	Axis speed command
MC_Jog	Axis jog command
MC_TorqueControl	Axis torque control
MC_Home	Axis homing

Basic Motion Control	Function
MC_Stop	Axis stop
MC_Halt	Axis pause
MC_ImmediateStop	Axis emergency stop
MC_MoveFeed	Axis interruption position
MC_MoveBuffer	Multi position command
MC_MoveSuperImposed	Axis position superimposed command
MC_MoveVelocityCSV	CSV velocity control(with PWM function)
MC_SyncMoveVelocity	CSV velocity control(with PWN function, without acceleration/deceleration)
MC_SyncTorqueControl	Sync torque control

Motion Control(EtherCAT & Pulse Output)

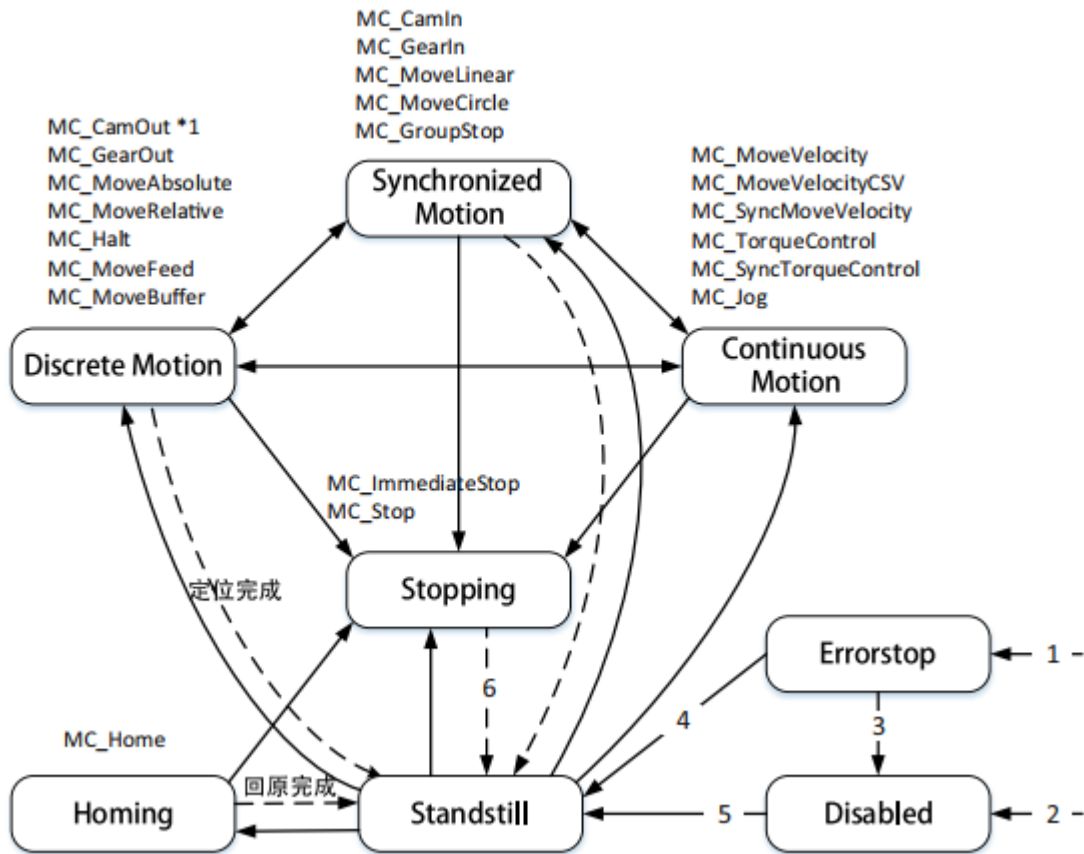

H5U manage axis based on PLCopen state machine.

- The state switch conditions show as below:
- While axis error detected
- While axis no error and MC_Power.Enable=OFF
- While using MC_Reset and MC_Power.Status=OFF
- While using MC_Reset and MC_Power.Status=ON
- While MC_Power.Enable=ON and MC_Power.Status=ON
- While MC_Stop(MC_ImmediateStop).Done=ON and MC_Stop(MC_ImmediateStop).Execute=OFF

➤ MC_Power

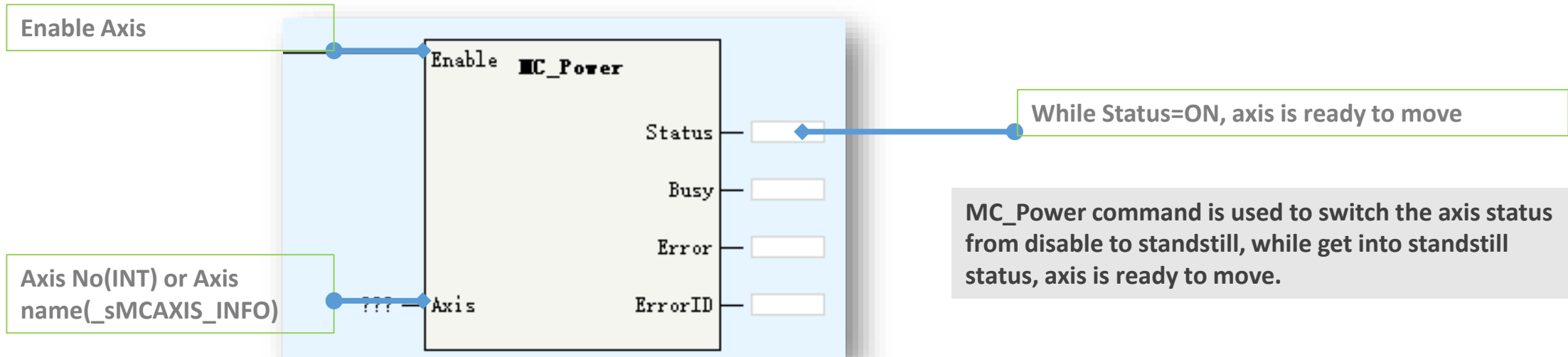

➤ MC_Reset

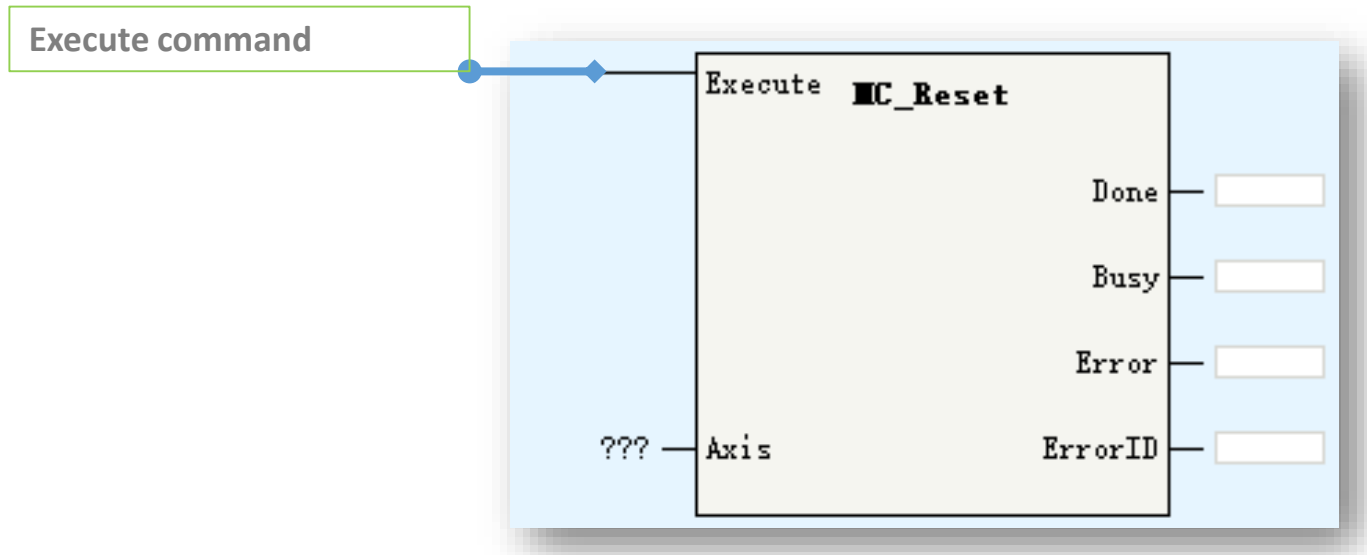

After MC_Reset.Done, axis get into disabled or standstill state.
 Be noted if using MC_Reset while there is no error of axis, this function block will have an error.

➤ MC_ReadStatus



While Enable=ON, this block will read axis PLCopen state and accelerating/decelerating state.
 In torque control mode, ConstantVelocity/Accelerating/Decelerating will be off.

Motion Control(EtherCAT & Pulse Output)

➤ MC_ReadAxisError

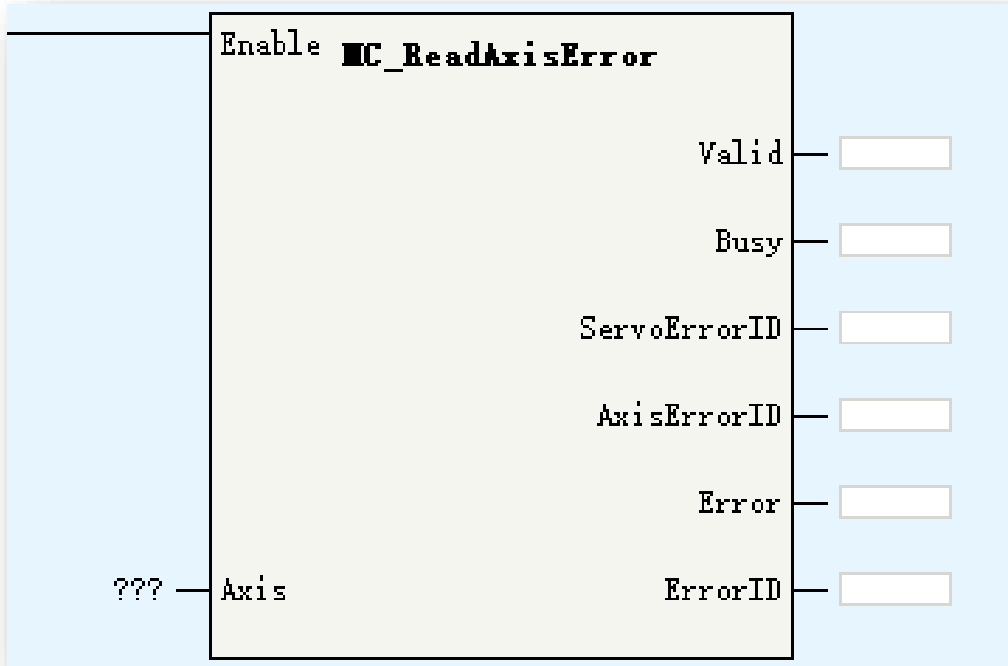

While Enable=ON, if the axis existed and there is no configuration error, <Valid> will be ON. <AxisErrorID> is used to show the error code, users can find the error information according to the error code(while <AxisErrorID>=0, there is no error). <ServoErrorID> display the value of 0x603F(while 0x603F configured in PDO, or <ServoErrorID> will display 0)

➤ MC_ReadDigitalInput

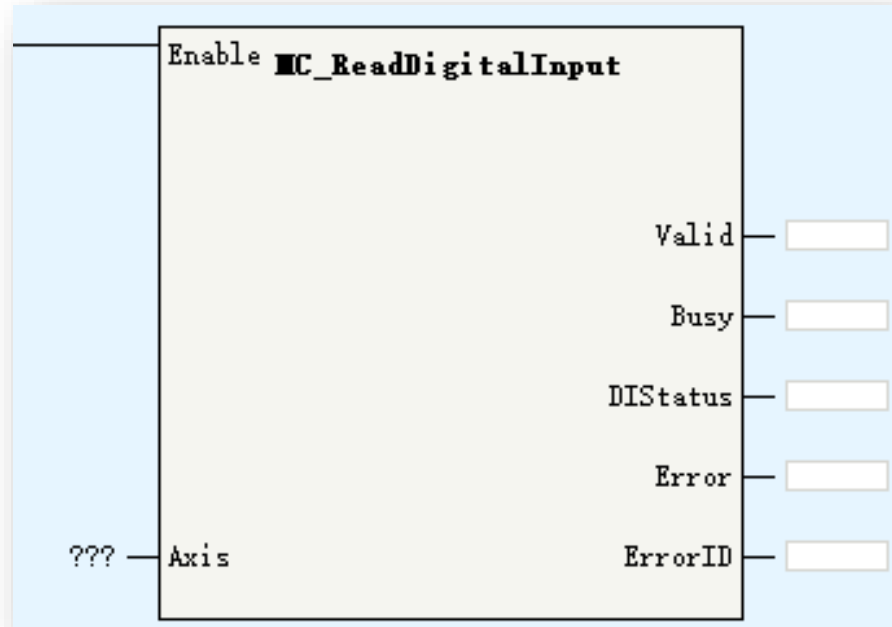

Read the digital input status of axis.
 While Enable=ON, if the EtherCAT axis or pulse axis positive limit/or negative limit enabled, the <Valid>=ON.

While using with EtherCAT axis, need configure 0x60FD in PDO.
 Details for input definition please find corresponding servo manual.

Motion Control(EtherCAT & Pulse Output)

[Back to Contents](#)

- MC_ReadActualPosition
- MC_ReadActualTorque
- MC_ReadActualVelocity

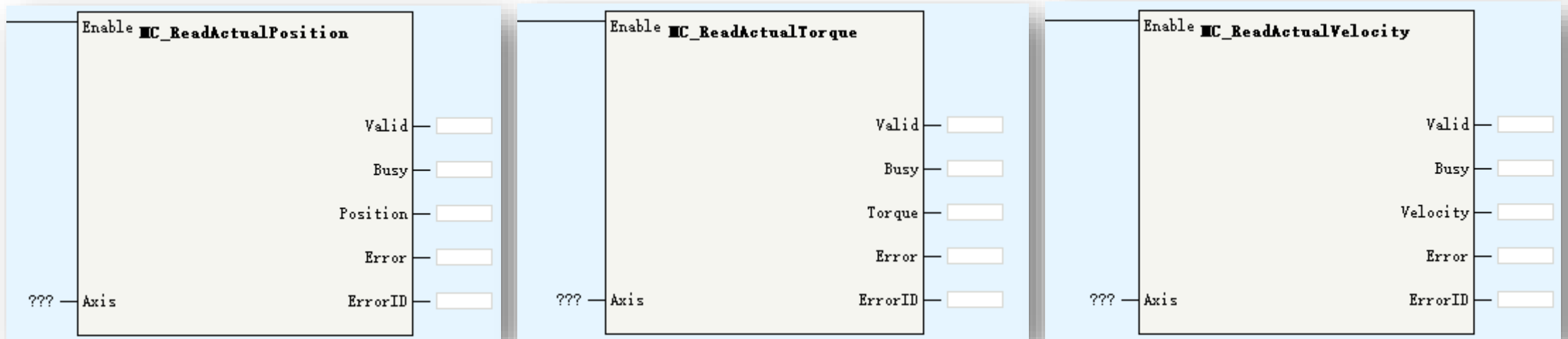

While Enable = ON,

For MC_ReadActualPosition, if 0x6064 configured in PDO, Valid=ON;

For MC_ReadActualTorque, if 0x6077 configured in PDO, Valid =ON;

For MC_ReadActualVelocity, if 0x606C configured in PDO, Valid =ON;

These FBs are used to read axis real time velocity/position/torque, besides, users can also read the axis structure directly to get this value by using `_sMCAXIS_INFO.dActPosition/_sMCAXIS_INFO.dActVelocity/_sMCAXIS_INFO.dActTorque`

Motion Control(EtherCAT & Pulse Output)

➤ MC_SetPosition

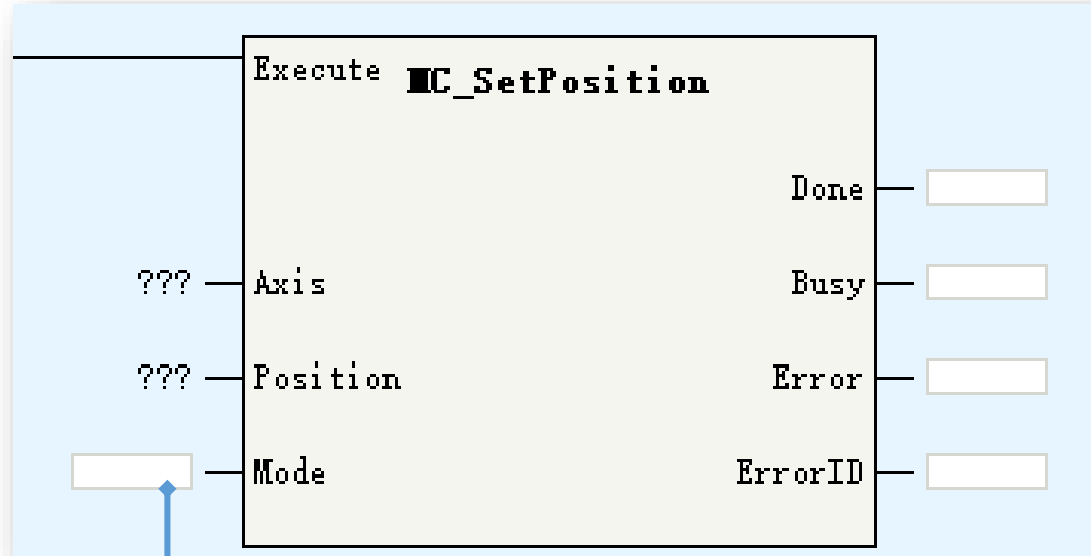

MC_Setposition can modify axis position without moving. Be noted, only in standstill/disabled/errorstop status, axis can execute this command, or the FB will have an error.

- 0: Absolute mode, set <Position> value as axis ActPosition
- 1: Relative mode, add <Position> value base on current ActPosition

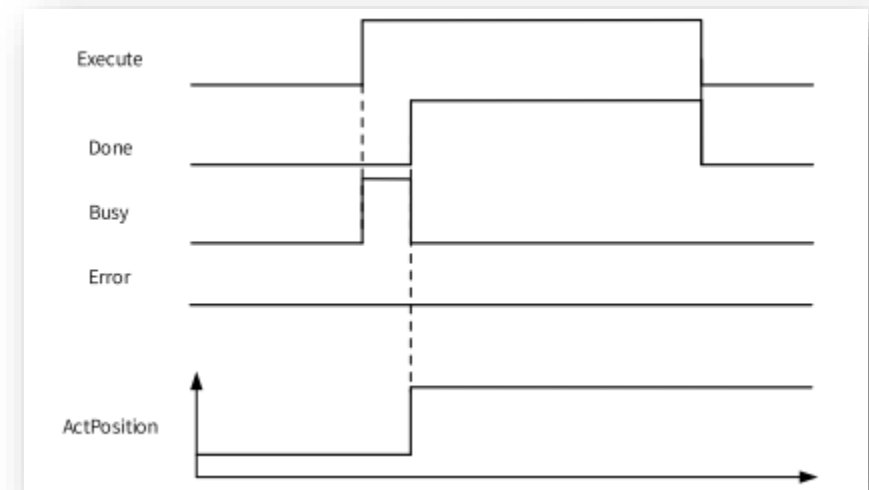

➤ MC_TouchProbe

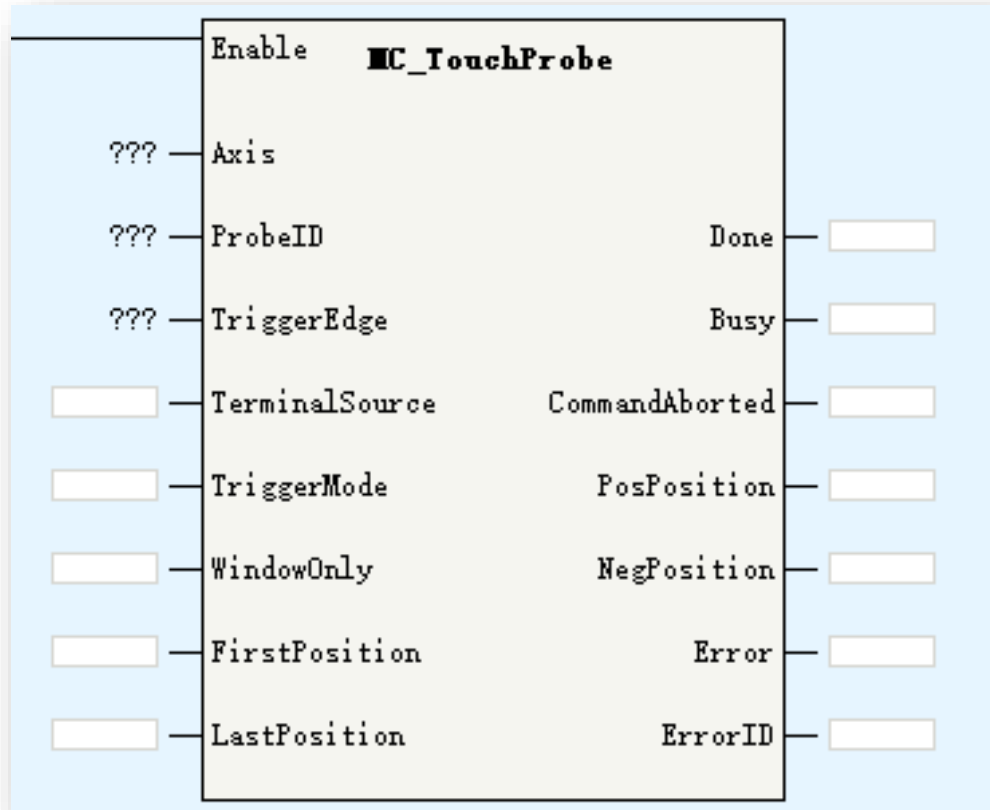

Parameters	Description
Axis	Axis ID/Axis name
ProbeID	0: TP1 1:TP2
TriggerEdge	0: rising edge 1:falling edge 2:both of rising and falling edge
TerminalSource	TP trigger source: 0:DI 1:encoder Z signal
TriggerMode	0: single 1: continuous
WindowOnly	0: disabled window function, detect TP signal in any position 1: enable window function, detect TP signal in <FirstPosition, LastPosition> range
FirstPosition	TP window start position
LastPosition	TP window last position
PosPosition	Positive(rising edge) latch value
NegPosition	Negative(falling edge) latch value

Touch probe FB is used to read the locked position value of servo while signal triggered without software delay, which means the latch position will not impacted by EtherCAT cycle and data transmission time.

Motion Control(EtherCAT & Pulse Output)

➤ MC_TouchProbe

While using local pulse axis, need configure the touch probe input in axis configuration view.
 While using field bus axis, need select touch probe related PDO in EtherCAT slave configuration.

The screenshot displays the configuration interface for the MC_TouchProbe. It is divided into several sections:

- Mode Selection:** Includes Mode Settings (Linear Mode selected), Software Limits (Enable checkbox), Error Response (Limit deceleration: 1000.0), Threshold setting (Follow error threshold: 100.00), Axis Speed Settings (Max speed: 1000.0, Jog Max speed: 500.00), and Options (Do not enter ErrorStop state after touching a limit checkbox).
- Probe Settings:** Contains checkboxes for Probe 1 and Probe 2 Enable, and dropdown menus for Probe 1 (X4) and Probe 2 (X4). A blue box highlights this section, with a line pointing to a 'Local Axis' label.
- Output Settings:** Shows Output mode set to Pulse Direction. A line points from this section to the 'EtherCAT axis' label.
- I/O Functional Mapping Table:** A table on the right lists various outputs and their indices. The 'Touch probe function' is highlighted with a blue box, and a line connects it to the 'EtherCAT axis' label.

Input/Output	Name	Index
<input checked="" type="checkbox"/> Output	Outputs	16#1701
<input type="checkbox"/> Output	Outputs	16#1702
<input type="checkbox"/> Output	Controlword	16#6040
<input type="checkbox"/> Output	Target position	16#607A
<input type="checkbox"/> Output	Target velocity	16#60FF
<input type="checkbox"/> Output	Target torque	16#6071
<input type="checkbox"/> Output	Modes of operation	16#6060
<input type="checkbox"/> Output	Touch probe function	16#60B8
<input type="checkbox"/> Output	Max profile velocity	16#607F

Motion Control(EtherCAT & Pulse Output)

➤ MC_TouchProbe

While <Enable>=ON(rising edge), FB will lock the input parameters.

If <WindowOnly>=OFF, the window detection function will not work, the touch probe in full position range.

If <WindowOnly>=ON, the window detection function will be enabled, in this case:

While axis is in linear mode, only when the touch probe triggered in <FirstPosition> and <LastPosition> range, the position value will be latched.

While axis is in rotation mode, firstly do modulo operation to the <FirstPosition> and <LastPosition> based on the rotation cycle. For example, if <FirstPosition> is set as 540, the rotation cycle is 360, then the $\langle 540 \text{ Mod } 360 \rangle = 180$. After modulo operation, we get the modulo value FirstPosition_P and LastPosition_P.

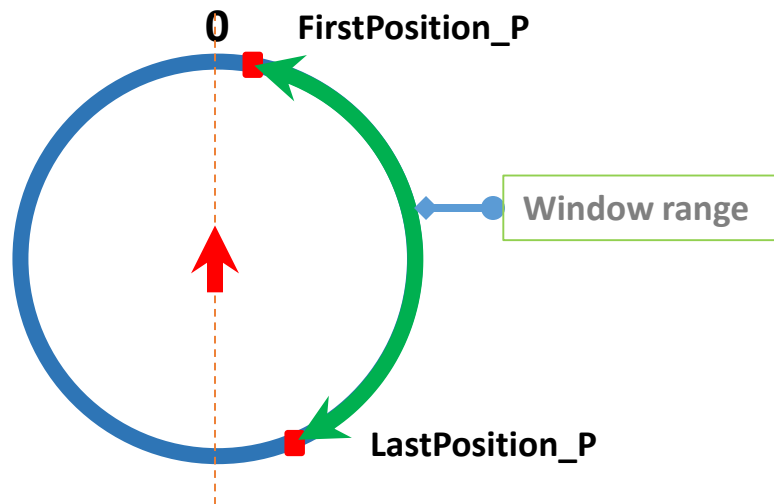

*While FirstPosition_P < LastPosition_P

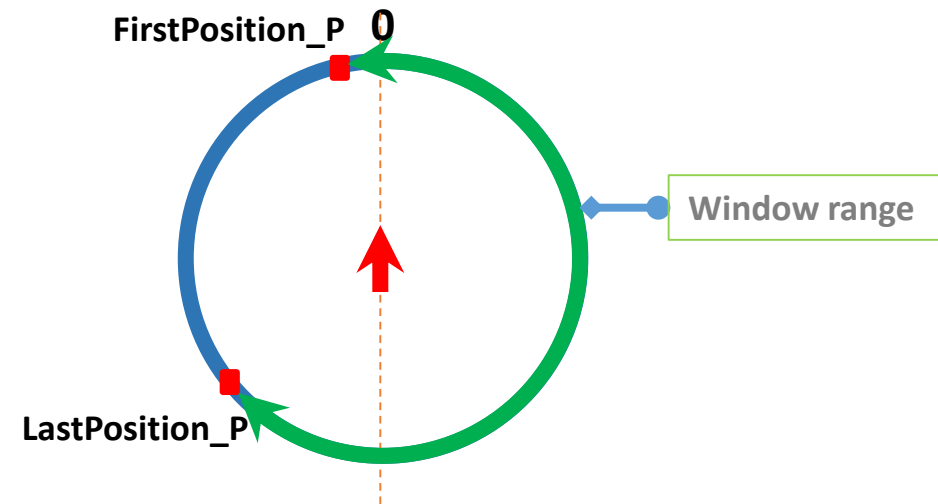

*While FirstPosition_P > LastPosition_P

➤ MC_MoveRelative

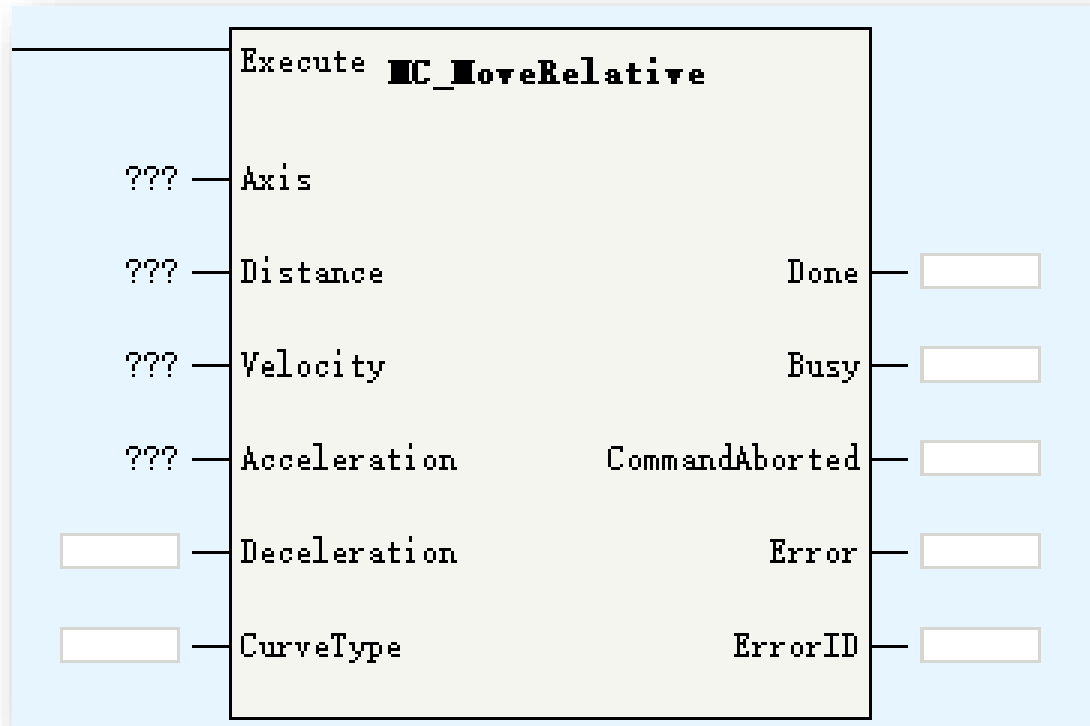

Parameters	Description
Axis	Axis ID/Axis name
Distance	Moving distance
Velocity	Moving velocity
Acceleration	Acceleration
Deceleration	Deceleration
CurveType	Velocity ACC/DEC curve: 0: T curve 1: S curve

This command works while axis in standstill/discretemotion/continousmotion status, after executing this command, axis get into discretemotion status.

➤ MC_MoveVelocity

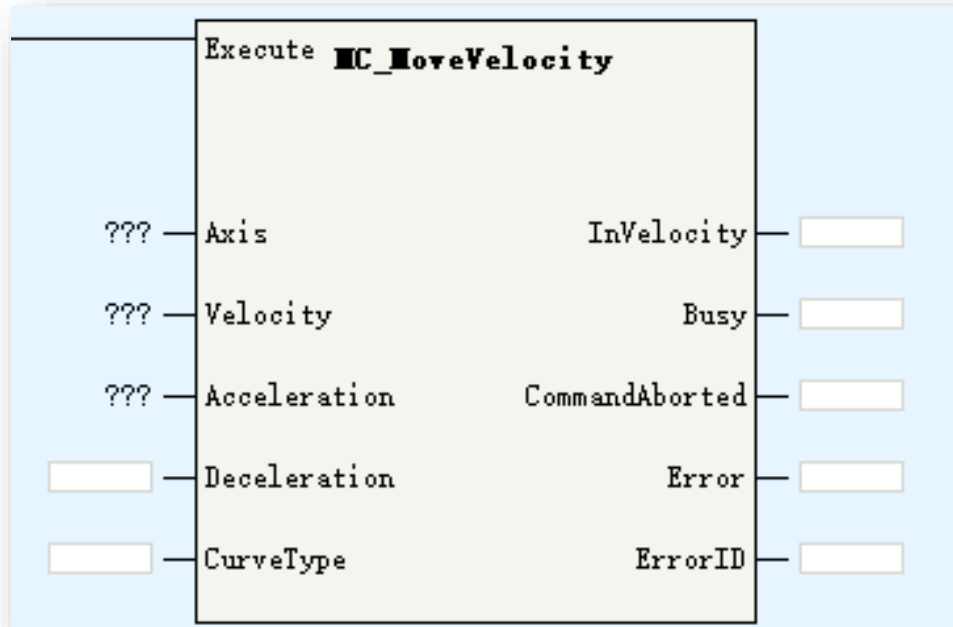

Parameters	Description
Axis	Axis ID/Axis name
Velocity	Target velocity
Acceleration	Acceleration
Deceleration	Deceleration
CurveType	Velocity ACC/DEC curve: 0: T curve 1: S curve
InVelocity	Up to target velocity

This command works while axis in standstill/discretemotion/continousmotion status, after executing this command, axis get into continousmotion status.

➤ MC_MoveAbsolute

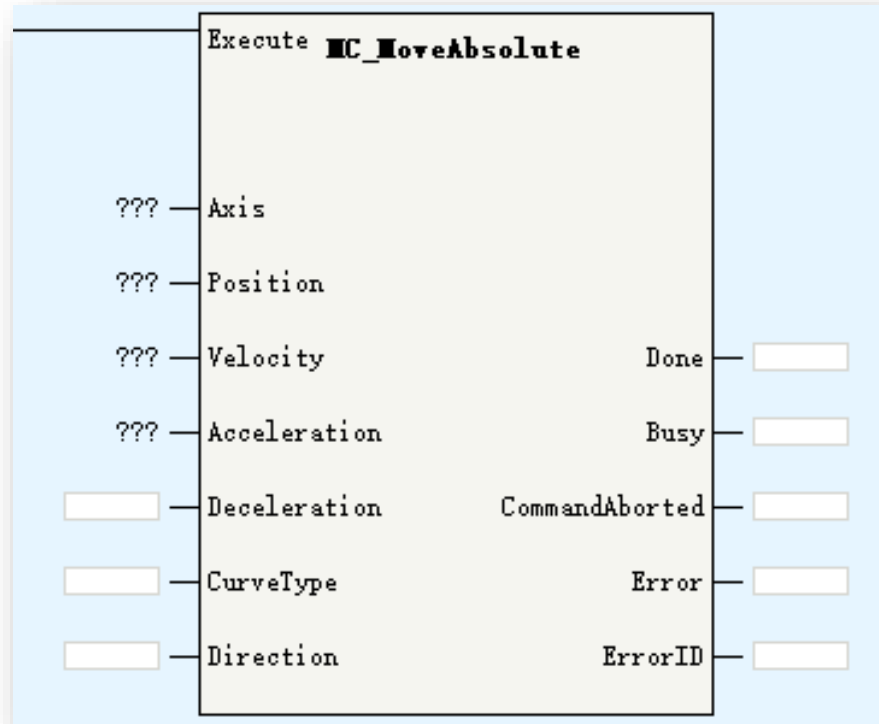

Parameters	Description
Axis	Axis ID/Axis name
Position	Target position
Velocity	Target velocity
Acceleration	Acceleration
Deceleration	Deceleration
CurveType	Velocity ACC/DEC curve: 0: T curve 1: S curve
Direction	Only works in rotation mode 0: positive 1: negative 2: shortest 3: current direction

This command works while axis in standstill/discretemotion/continousmotion status, after executing this command, axis get into discretemotion status.

➤ MC_Jog

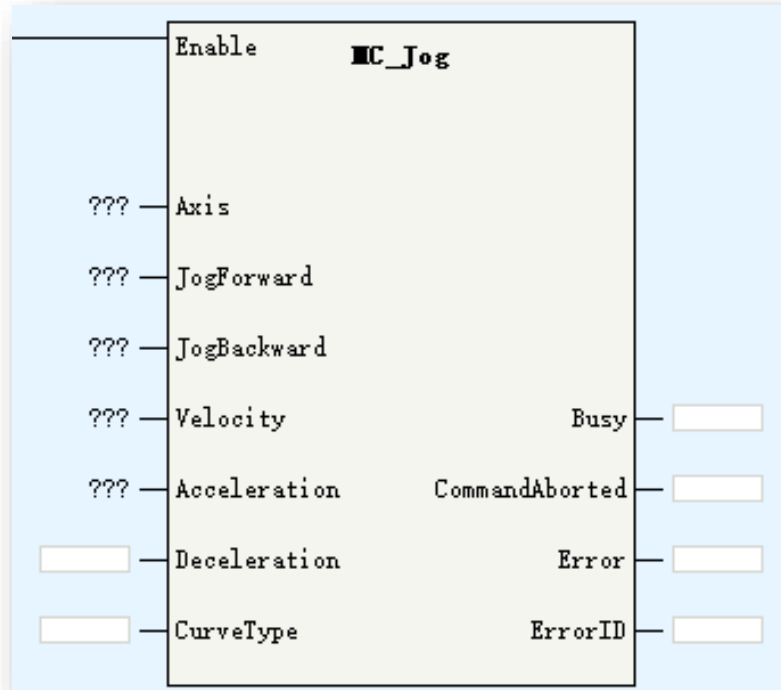

Parameters	Description
Axis	Axis ID/Axis name
JogForward	Moving forward
JogBackward	Moving backward
Velocity	Target velocity
Acceleration	Acceleration
Deceleration	Deceleration
CurveType	Velocity ACC/DEC curve: 0: T curve 1: S curve

This command works while axis in standstill/discretemotion/continousmotion status, after executing this command, axis get into continousmotion status. While JogForward and JogBackward enabled at the same time, the FB will report an error, but axis will not get into errorstop status.

Motion Control(EtherCAT & Pulse Output)

➤ MC_TorqueControl

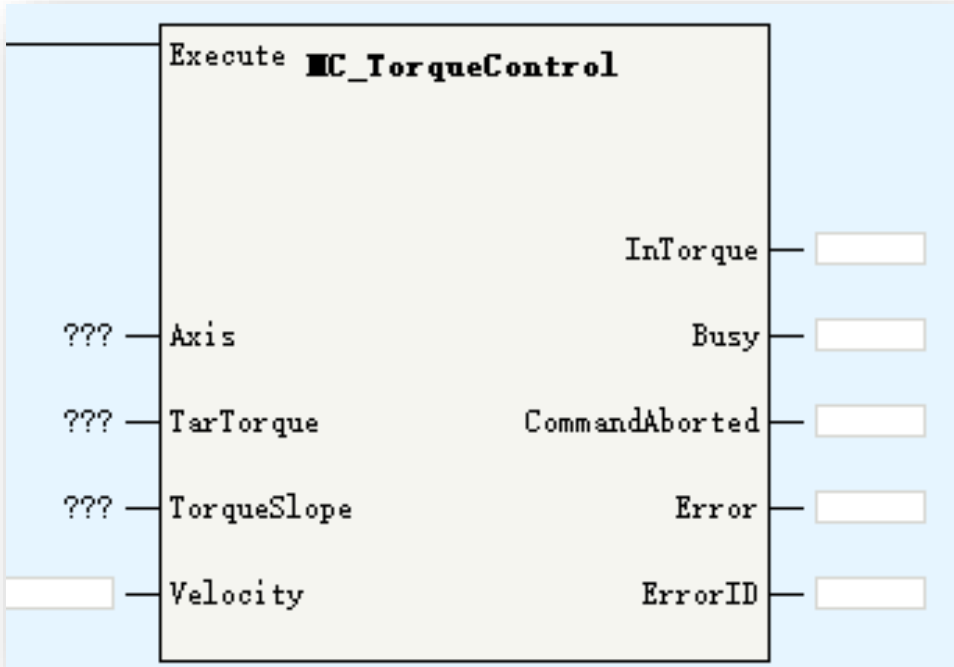

Parameters	Description
Axis	Axis ID/Axis name
TarTorque	Target torque(unit 1%)
TorqueSlope	Torque slope(unit 1%)
Velocity	Limit velocity
InTorque	While difference of target torque and set torque in 5%, InTorque valid

This command works while axis in standstill/discretemotion/continousmotion status, after executing this command, axis get into continousmotion status.

➤ MC_Home

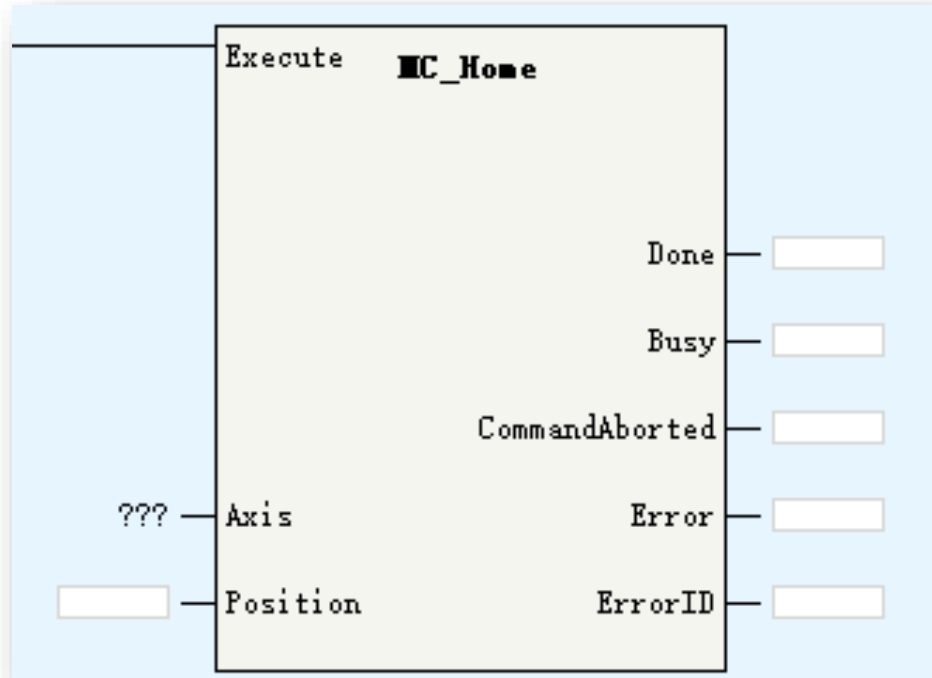

Parameters	Description
Axis	Axis ID/Axis name
Position	Origin offset

The screenshot shows the configuration interface for the MC_Home command. It includes several settings sections:

- Basic Settings:** Home signal (Unassigned), Z Signal (Unassigned).
- Unit Conversion Settings:** Positive Limit (Unassigned), Negative Limit (Unassigned).
- Mode/Parameter Settings:** Home Return Direction (Unassigned), Home Input Detection Direction (Unassigned).
- Home Return Settings:** Home return list (Zero Back?), Home return speed (10.0 Unit/s), Home return acceleration (100.0 Unit/s²), Home Return Close Speed (2.0 Unit/s), Home return timeout (50000 *10ms).
- Online Debug:** A timing diagram showing Motor Z Signal, Homing switch Signal, Positive limit switch, and Deceleration point signal. The diagram illustrates the sequence of events during homing, including the detection of the homing switch and the subsequent deceleration to a stop.

This command works while axis in standstill status, after executing this command, axis get into homing status. Homing related parameters set in [axis configuration](#). While axis in virtual mode, the homing method is CIA402 No. 35.

➤ MC_Stop

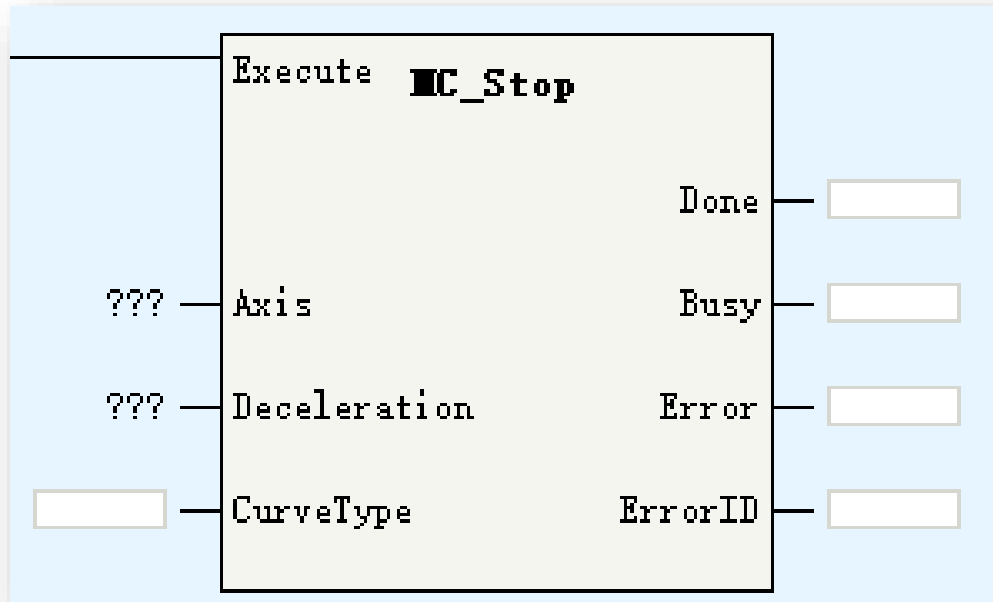

Parameters	Description
Axis	Axis ID/Axis name
Deceleration	Stop deceleration
CurveType	Velocity ACC/DEC curve: 0: T curve 1: S curve

After executing MC_Stop, axis get into stopping state.
 While stopping complete, <Done> signal valid,
 if execute is ON, axis is still in stopping state, IF Execute is OFF, axis get into standstill state.
 This command can be aborted by MC_ImmediateStop, while aborted, there is FB error 9142 occur.

➤ MC_Halt

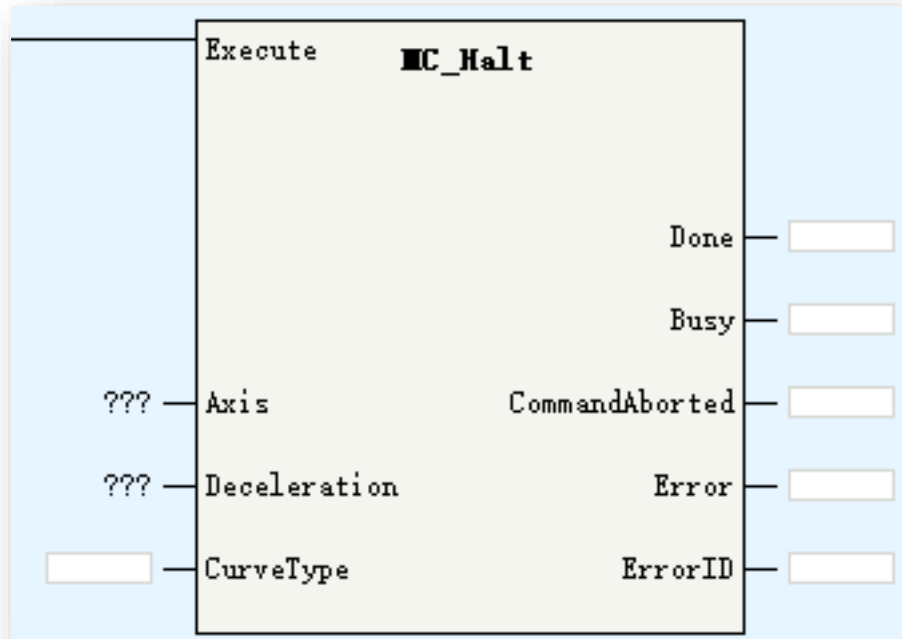

Parameters	Description
Axis	Axis ID/Axis name
Deceleration	Stop deceleration
CurveType	Velocity ACC/DEC curve: 0: T curve 1: S curve

MC_Halt is used to pause an axis motion. After executing MC_Halt, axis get into discrete motion state. This command can be aborted by MC_Stop/MC_immediateStop and other motion control FBs.

Motion Control(EtherCAT & Pulse Output)

➤ MC_MoveFeed

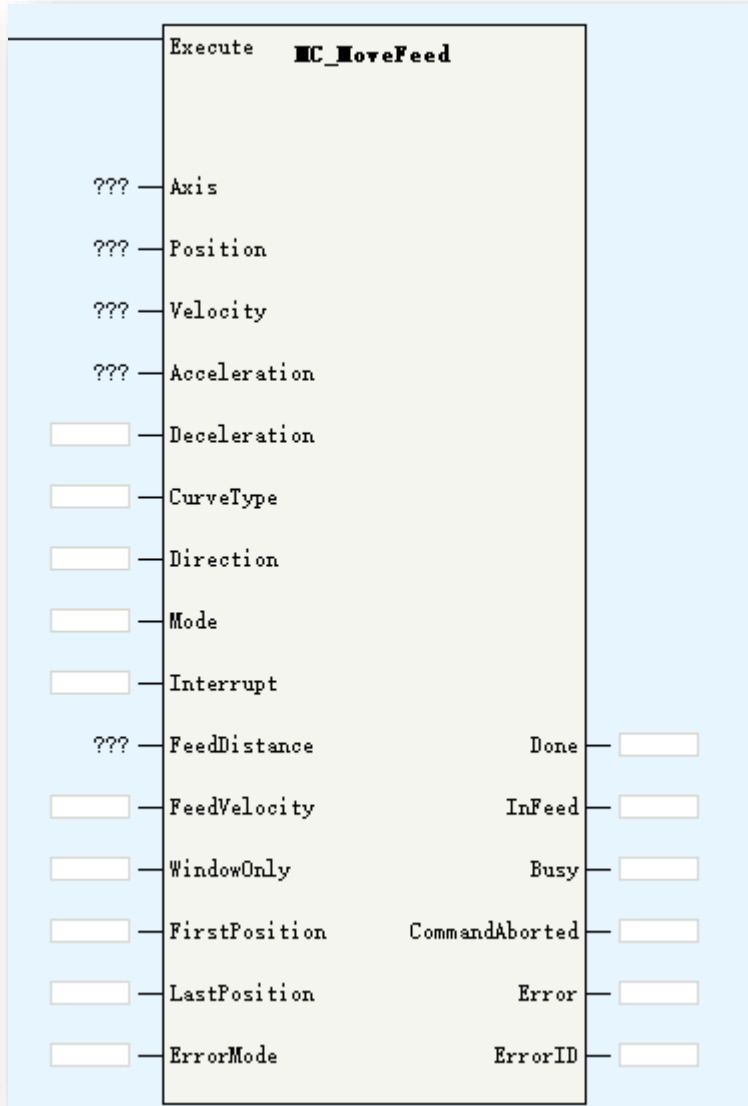

Parameters	Description
Axis	Axis ID/Axis name
Position	Target position
Velocity	Target velocity
Acceleration	Acceleration
Deceleration	Deceleration
CurveType	Velocity ACC/DEC curve: 0: T curve 1: S curve
Direction	Rotation mode absolute position direction: 0:pos 1:neg 2:shortest 3:current
Mode	0:abs 1:rel 2:vel
Interrupt	0:TP1 1:TP2
FeedDistance	Position after interruption signal triggered: Positive value means move current direction a certain distance, negative value means move revert direction a certain distance
FeedVelocity	Velocity after interruption signal triggered
WindowOnly	Window function: 0:disabled 1:enabled
FirstPosition	Interruption window start position
LastPosition	Interruption window end position
ErrorMode	While up to <Position>, if there is no interruption signal detected: 0:no error 1:error
InFeed	Interruption signal valid

Motion Control(EtherCAT & Pulse Output)

➤ MC_MoveFeed

MC_MoveFeed is used to move a certain distance according to interruption signal in a moving process.

Before the interruption signal triggered, axis move according to the parameters <Position>/<Velocity>/<Acceleration>/<Deceleration>/<Mode>, while the interruption signal triggered, axis move relatively according to the parameters <FeedPosition>/<FeedVelocity>.

Be noted if there is no interruption signal triggered during this process, the FB will report an error according to the parameters <ErrorMode>. The output parameter <Infeed> will indicate is there an interruption signal during this process.

While executing this command, axis get into discrete motion status, can be aborted by other motion FBs according to PLCopen state machine.

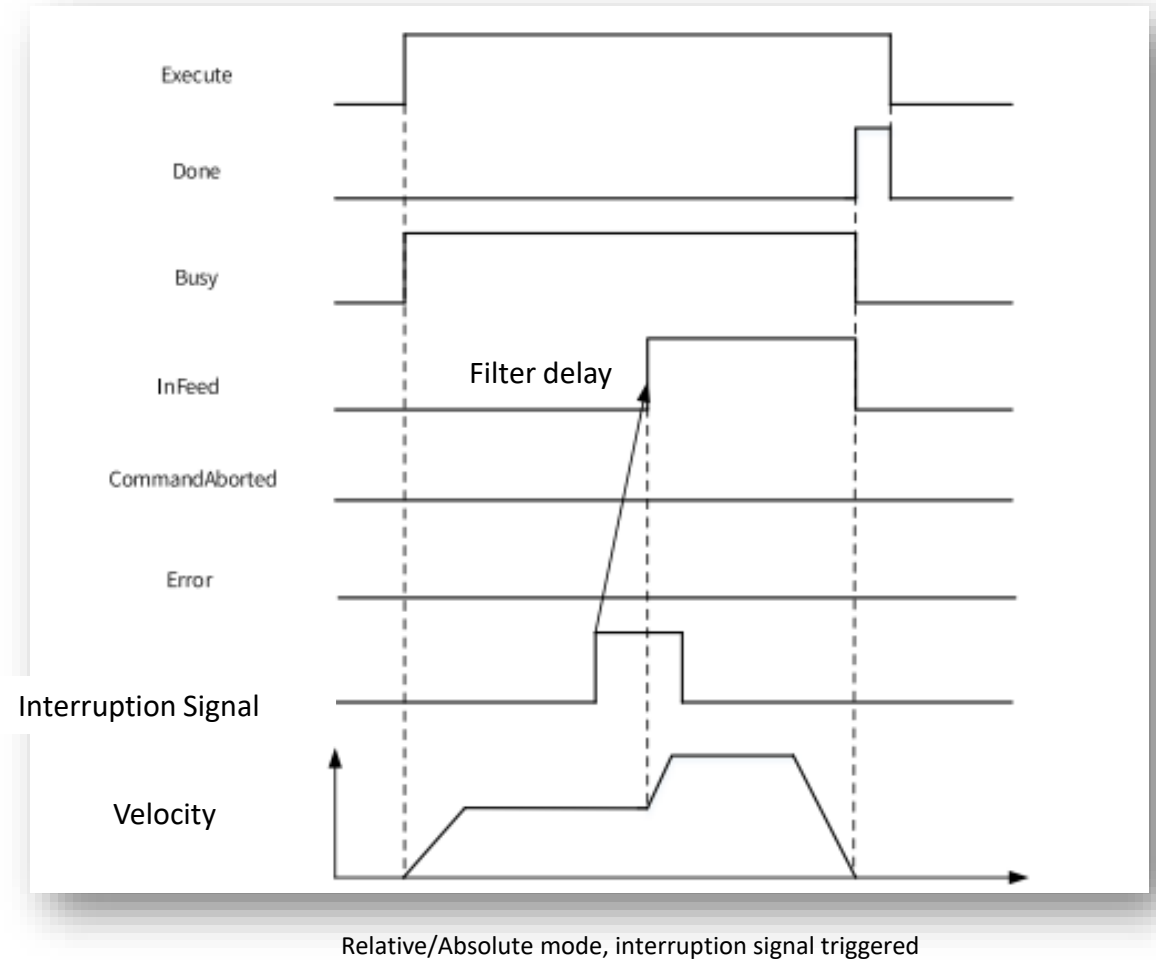

Motion Control(EtherCAT & Pulse Output)

➤ MC_MoveBuffer

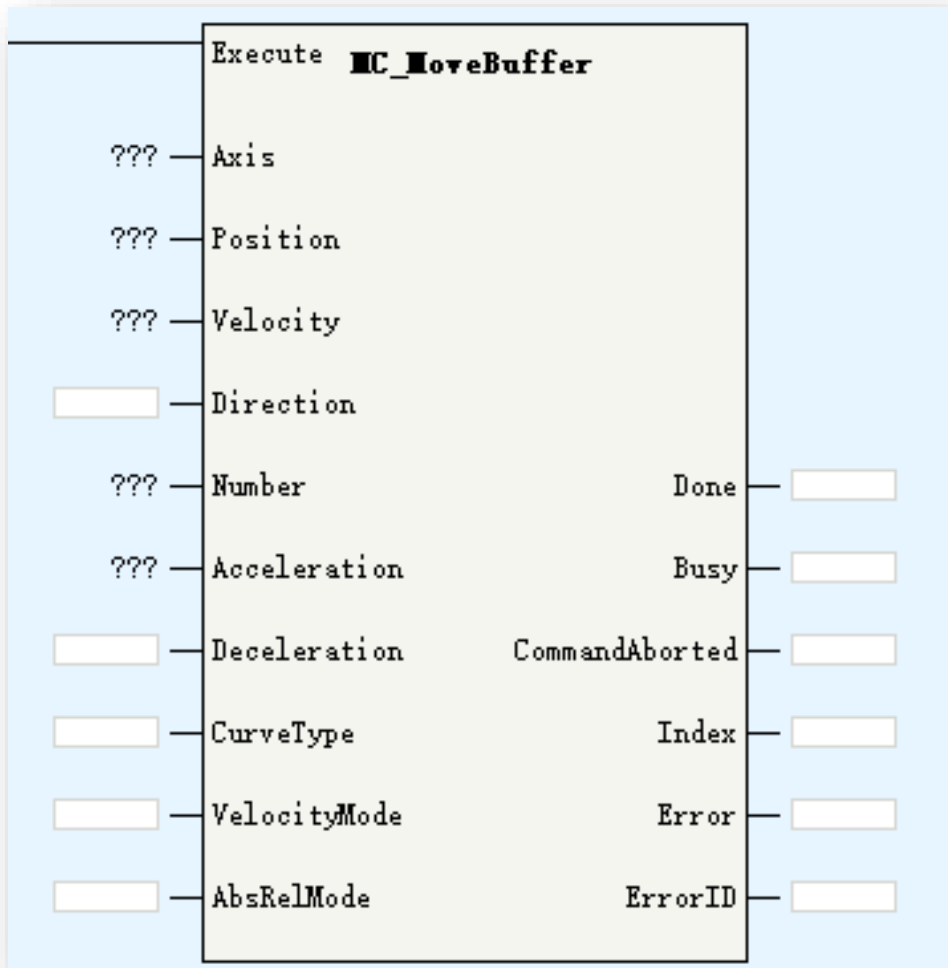

Parameters	Description
Axis	Axis ID/Axis name
Position	Target position
Velocity	Target velocity
Direction	Rotation mode absolute position direction: 0:pos 1:neg 2:shortest 3:current
Number	Buffer data quantity(up to 16)
Acceleration	Acceleration
Deceleration	Deceleration
CurveType	Velocity ACC/DEC curve: 0: T curve 1: S curve
VelocityMode	0: decrease to 0 then get into next position stage 1: keep current speed to get into next stage
AbsRelMode	0:abs 1:rel
Index	Index of current position stage

Motion Control(EtherCAT & Pulse Output)

➤ MC_MoveBuffer

MC_MoveBuffer is used for multi-position function. It can support up to 16 position segment.

Be noted the <Position>/<Velocity>/<Direction> are array type parameters, the length is depend on the buffer <Number>. The first position segment parameters is <Position>[0]/<Velocity>[0]/<Direction>[0], and so on for other segments.

This command works while axis in standstill/discrete motion/continuous motion status.

While executing this command, axis get into discrete motion status, can be aborted by other motion FBs according to PLCopen state machine.

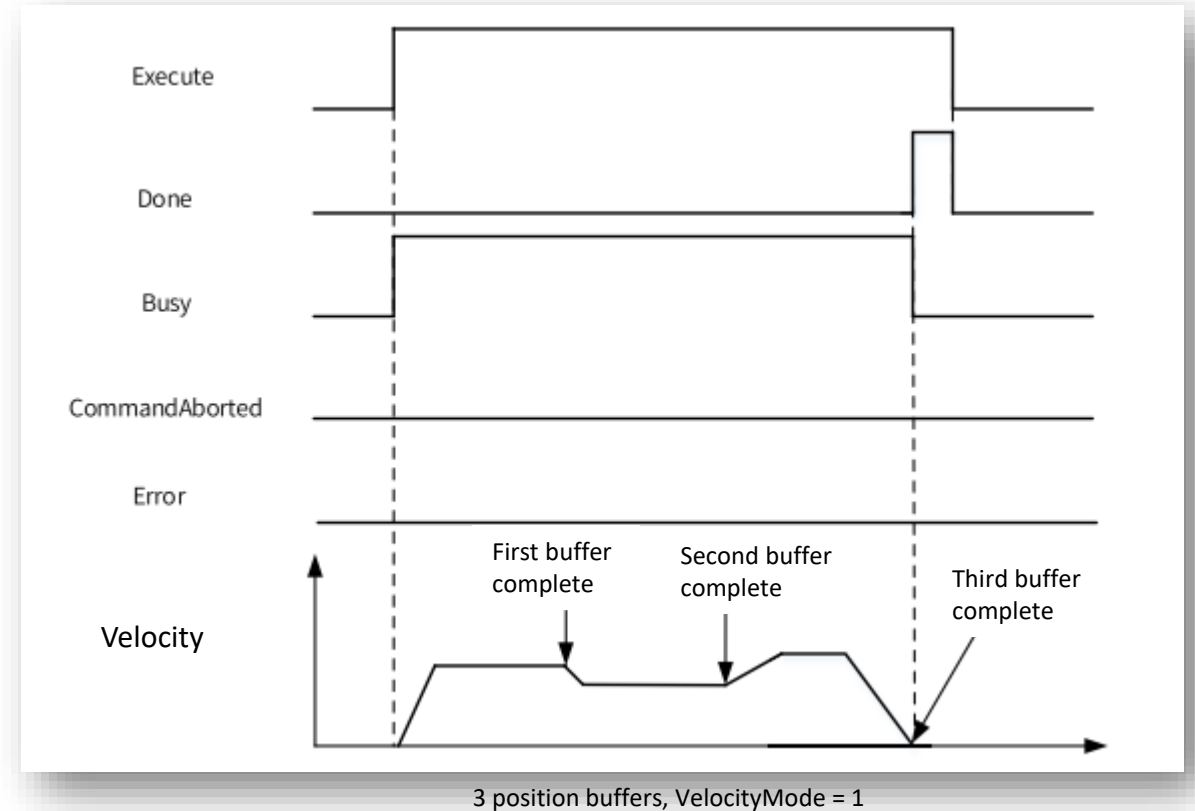

➤ MC_MoveSuperImposed

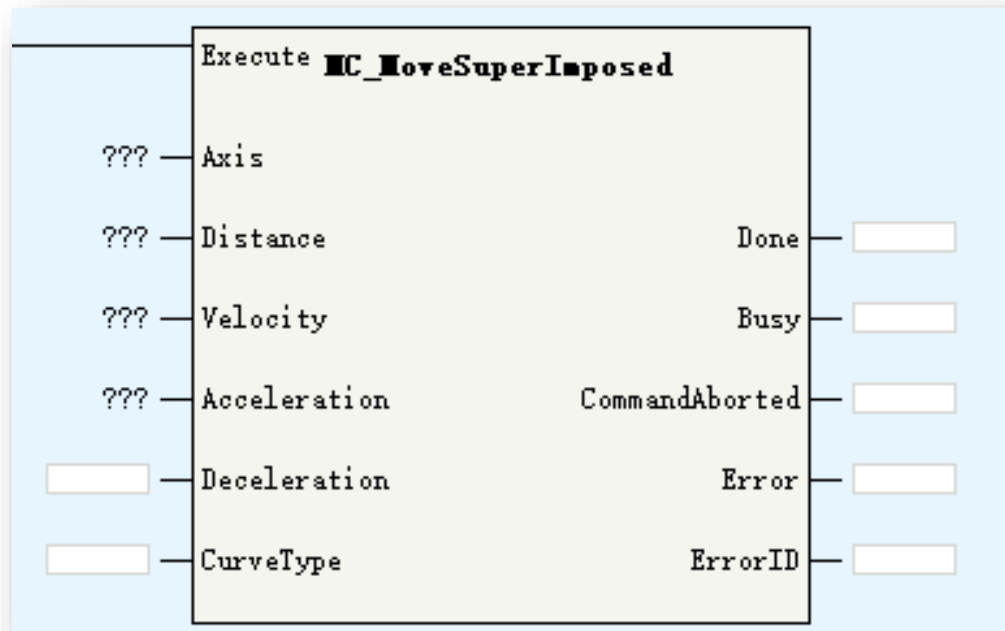

Parameters	Description
Axis	Axis ID/Axis name
Distance	Compensation position
Velocity	Target velocity
Acceleration	Acceleration
Deceleration	Deceleration
CurveType	Velocity ACC/DEC curve: 0: T curve

MC_MoveSuperImposed is used to superimposed a distance based on current motion.
 Not work when MC_Halt, axes group commands are using.
 Works only in CSP mode.
 Applicable to CAM/GEAR command. MC_CamOut/MC_GearOut can stop this command.
 After executing this command, axis get into discrete motion, can be aborted by other motion FBs.

➤ MC_MoveVelocityCSV

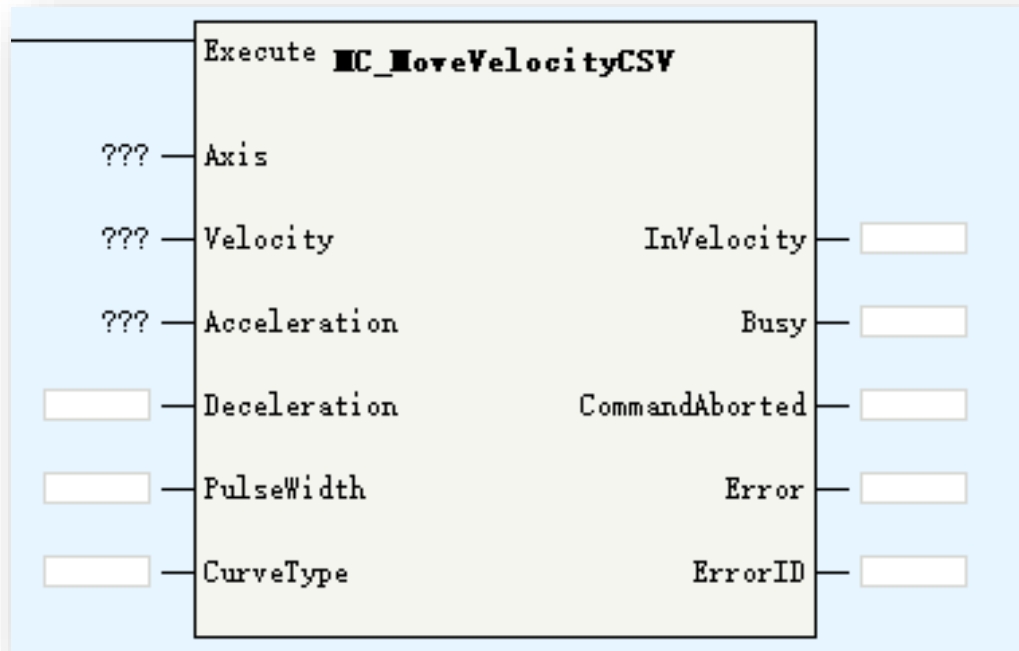

Parameters	Description
Axis	Axis ID/Axis name
Velocity	Target velocity
Acceleration	Acceleration
Deceleration	Deceleration
PulseWidth	Pulse width, unit: 0.01%
CurveType	Velocity ACC/DEC curve: 0: T curve 1:S curve
InVelocity	Get into target velocity

This command control axis in CSV mode.

While using with EtherCAT axis, same function with MC_MoveVelocity.

While using with pulse control axis, this FB can control hardware to output PWM curve, the <PulseWidth> is used to control the output pulse width.

Motion Control(EtherCAT & Pulse Output)

➤ MC_SyncMoveVelocity

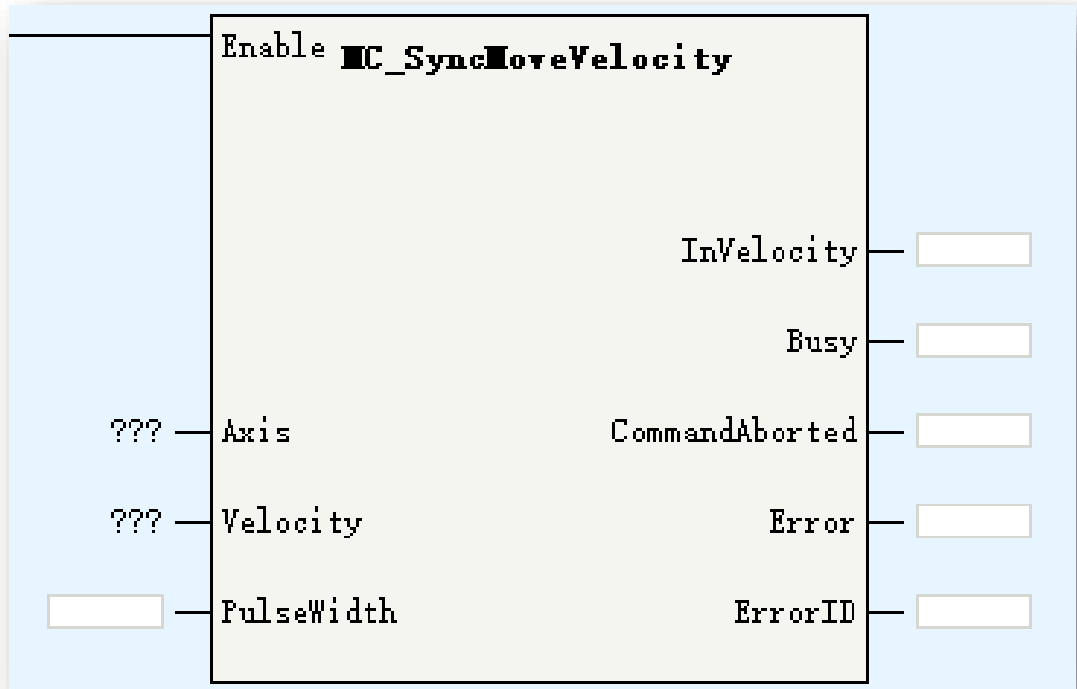

Parameters	Description
Axis	Axis ID/Axis name
Velocity	Target velocity
PulseWidth	Pulse width, unit: 0.01%
InVelocity	Get into target velocity

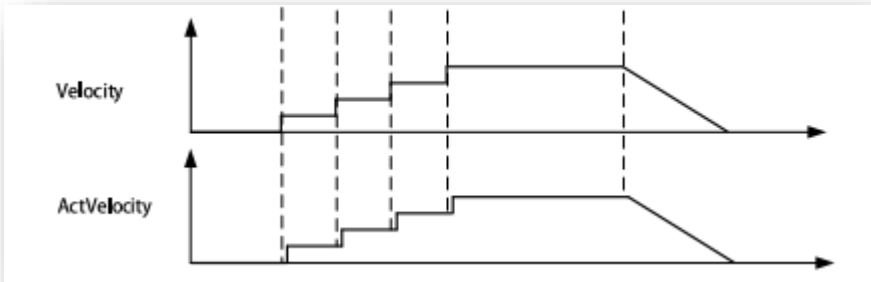

This command control axis in CSV mode. Almost same with MC_MoveVelocityCSV, the difference is this command have no acceleration and deceleration.

➤ MC_SyncTorqueControl

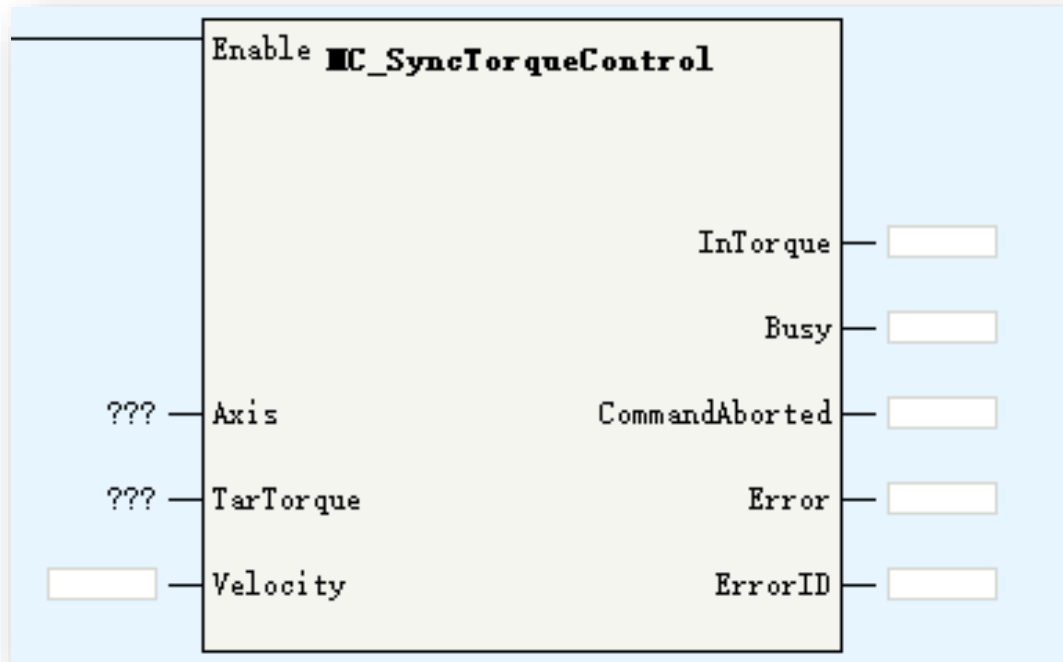

Parameters	Description
Axis	Axis ID/Axis name
TarTorque	Target torque(1%)
Velocity	Velocity limit
InTorque	Get into target torque

Work in CST mode.
Same with MC_TorqueControl.

➤ MC_SetAxisConfigPara



Parameters	Description
Axis	Axis ID/Axis name
ParameterIndex	-1: All parameters valid, works on disabled state 0: All parameters invalid 100: Modify gear ratio 200: Modify pos/neg software limit 300: modify linear/rotation mode 400: modify encoder mode 500: modify homing mode 600: modify hardware limit and origin signal 700: modify pulse output format 800: modify revert setting 900: modify virtual axis mode 1000: modify touch probe signal 1100: modify software limit variable

This command is used to modify axis configuration parameters. Parameters modifications may cause the position mutation, please execute homing operation after modifying these parameters if necessary.

Motion Control(EtherCAT & Pulse Output)

➤ MC_SetAxisConfigPara

ParameterIndex	Description	Work state
100	Gear ratio: dPulsePreCycle: pulse of 1 revolution fDistancePreCycle: displacement of workbench per round dNumerator: gear ratio numerator dDenominator: gear ratio denominator	Disabled
200	bSoftLimitEnable: enable software limit fPLimit: positive limit value (linear mode) fNLimit: negative limit value (linear mode)	Disabled/Standstill
300	iLineRotateMode: 0-linear mode 1-rotation mode fRotation: cycle of rotation mode	Disabled
400	iEncoderMode: 0-absolute 1-relative	Disabled
500	fHomeMethod: homing method fHomeVelocity: homing velocity fHomeApproachVelocity: homing approach velocity fHomeAcceleration :homing acceleration dHomeTimeOut: homing timeout dHomePositionMode: homing position mode selection	Disabled/Standstill
600	bPLimitTerminalPolarity: positive limit polarity: OFF-positive ON-negative bNLimitTerminalPolarity: negative limit polarity: OFF-positive ON-negative bHomeTerminalPolarity: origin point polarity: OFF-positive ON-negative dPLimitTerminalID: positive limit signal ID(Modbus address) dNLimitTerminalID negative limit signal ID(Modbus address) dHomeTerminalID origin signal ID(Modbus address)	Disabled
700	iPulseMethod: pulse output format 3-AB phase 4-pulse + direction 5-CW/CCW	Disabled
800	bDirection: OFF-positive ON-Negative	Disabled

Motion Control(EtherCAT & Pulse Output)

➤ MC_SetAxisConfigPara

ParameterIndex	Description	Work state
900	bVirtualMode: OFF-virtual mode invalid ON-virtual mode valid	Disabled
1000	dTouchProbeID1: touch probe 1 ID dTouchProbeID2: touch probe 2 ID	Disabled
1100	fLimitDeceleration fErrorStopDeceleration fFollowErrorWindow fInvelocityWindow fMaxVelocity fMaxJogVelocity fMaxAcc fMaxPTorque fMaxNTorque bEtherErrorStop: get into <errorstop> state while axis in error: OFF-invalid ON-valid	Disabled/Standstill

Modify axis linear/rotation mode configuration in program. All these configuration parameters are in the structure `_scfgAxis`. User can access these parameters by `<AxisName>.sConfig.<ParameterName>`.

```

M8000
[
  MOV      K1      Axis_0.sConfig.iLineRotateMode ]
  Linear / rotary mode selection
[
  DEMOV    E360.0  Axis_0.sConfig.fRotation
  Rotation period in rotation mode
]
Execute MC_SetAxisConfigPara

```

INT

Parameter Index

-1: update all;

0: ignore all;

100: modify gear ratio only;

200: modify positive and negative software limit only;

300: modify linear / rotation mode only;

others: refer to manual

Done

Busy

CommandAborted

Error

ErrorID

K300 ParameterIndex

Motion Control(EtherCAT & Pulse Output)

➤ MC_FollowVelocity

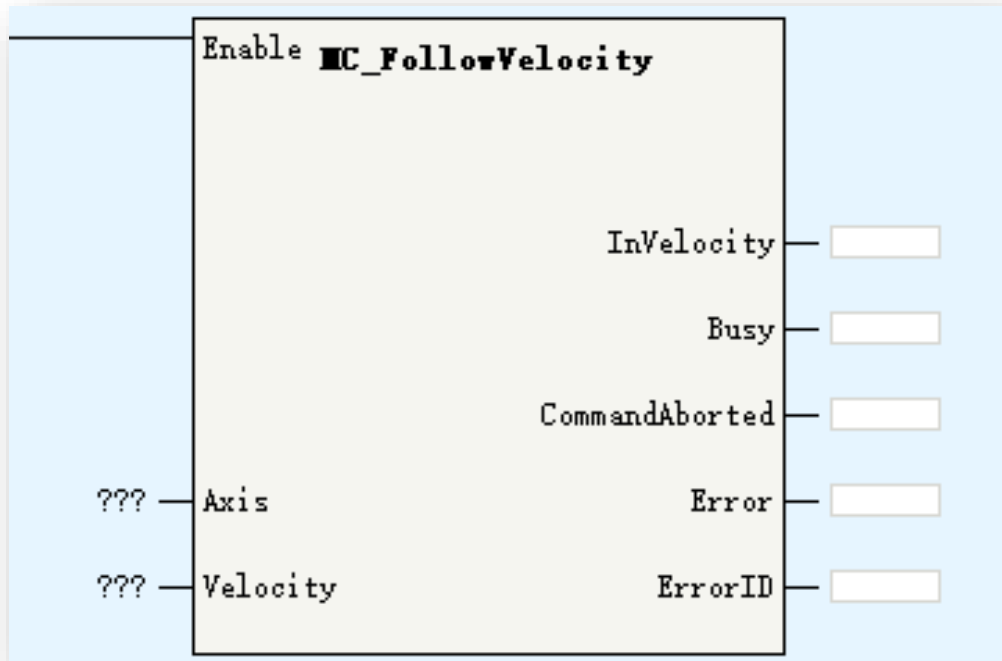

Parameters	Description
Axis	Axis ID/Axis name
TarTorque	Target torque(1%)
Velocity	Velocity limit
InTorque	Get into target torque

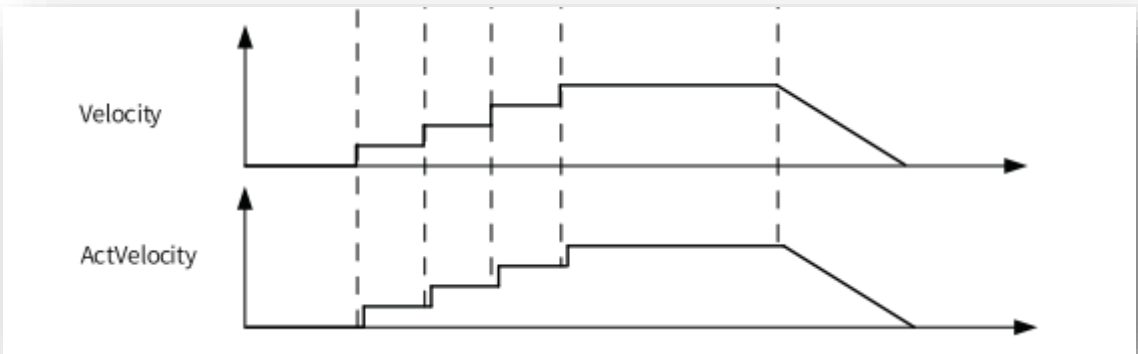

This command almost same with MC_SyncVelocity. The difference is this command works in CSP mode, can used with the MC_SuperImposed. While <Enable> =ON, the modification of <Velocity will effect immediately without acceleration/deceleration delay. While executing this command, axis get into synchronized motion state.

Motion Control(EtherCAT & Pulse Output)

CAM and GEAR	Function
MC_CamIn	Enable CAM
MC_CamOut	Disable CAM
MC_GetCamTablePhase	Get CAM phase(master position)
MC_GetCamTableDistance	Get CAM distance(slave position)
MC_GearIn	Enable GEAR
MC_GearOut	Disable GEAR
MC_Phasing	Master phase offset
MC_SaveCamTable	Save CAM table
MC_GenerateCamTable	Update CAM table
MC_DigitalCamSwitch	CAM tappet function

Motion Control(EtherCAT & Pulse Output)

➤ MC_CamIn

Execute		MC_CamIn	
Master	Master		
Slave	Slave		
CamTable	CamTable		
Cam.CamIn_Periodic	Periodic		
Cam.CamIn_StartMode	StartMode	CamInNode	Cam.CamIn_CamInNode
Cam.CamIn_StartPosition	StartPosition	InCam	Cam.CamIn_InCam
Cam.CamIn_MasterStartDistance	MasterStartDistance	InSync	Cam.CamIn_InSync
Cam.CamIn_MasterScaling	MasterScaling	EndOfProfile	Cam.CamIn_EndOfProfile
Cam.CamIn_SlaveScaling	SlaveScaling	Index	Cam.CamIn_Index
Cam.CamIn_MasterOffset	MasterOffset	Busy	Cam.CamIn_Busy
Cam.CamIn_SlaveOffset	SlaveOffset	Active	Cam.CamIn_Active
Cam.CamIn_ReferenceType	ReferenceType	CommandAborted	Cam.CamIn_CommandAbort
Cam.CamIn_Direction	Direction	Error	Cam.CamIn_Error
Cam.CamIn_BufferMode	BufferMode	ErrorID	Cam.CamIn_ErrorID

Parameters	Description
Master	Master axis: support EtherCAT axis, pulse control axis, Fieldbus encoder axis and local encoder axis
Slave	Slave axis: support EtherCAT axis and pulse control axis
CamTable	Cam table selection
Periodic	CAM cycle mode: 0:periodic Other: specified certain cycle numbers
StartMode	Master distance mode: 0:abs 1:rel 2:immediate
StartPosition	Start position of CAM table
MasterStartDistance	Master start distance
MasterScaling	Master scale factor
SlaveScaling	Slave scale factor
MasterOffset	Master offset
SlaveOffset	Slave offset
ReferenceType	Reference position: 0: last cycle set position 1: current cycle set position 2:current cycle feedback position

Motion Control(EtherCAT & Pulse Output)

➤ MC_CamIn

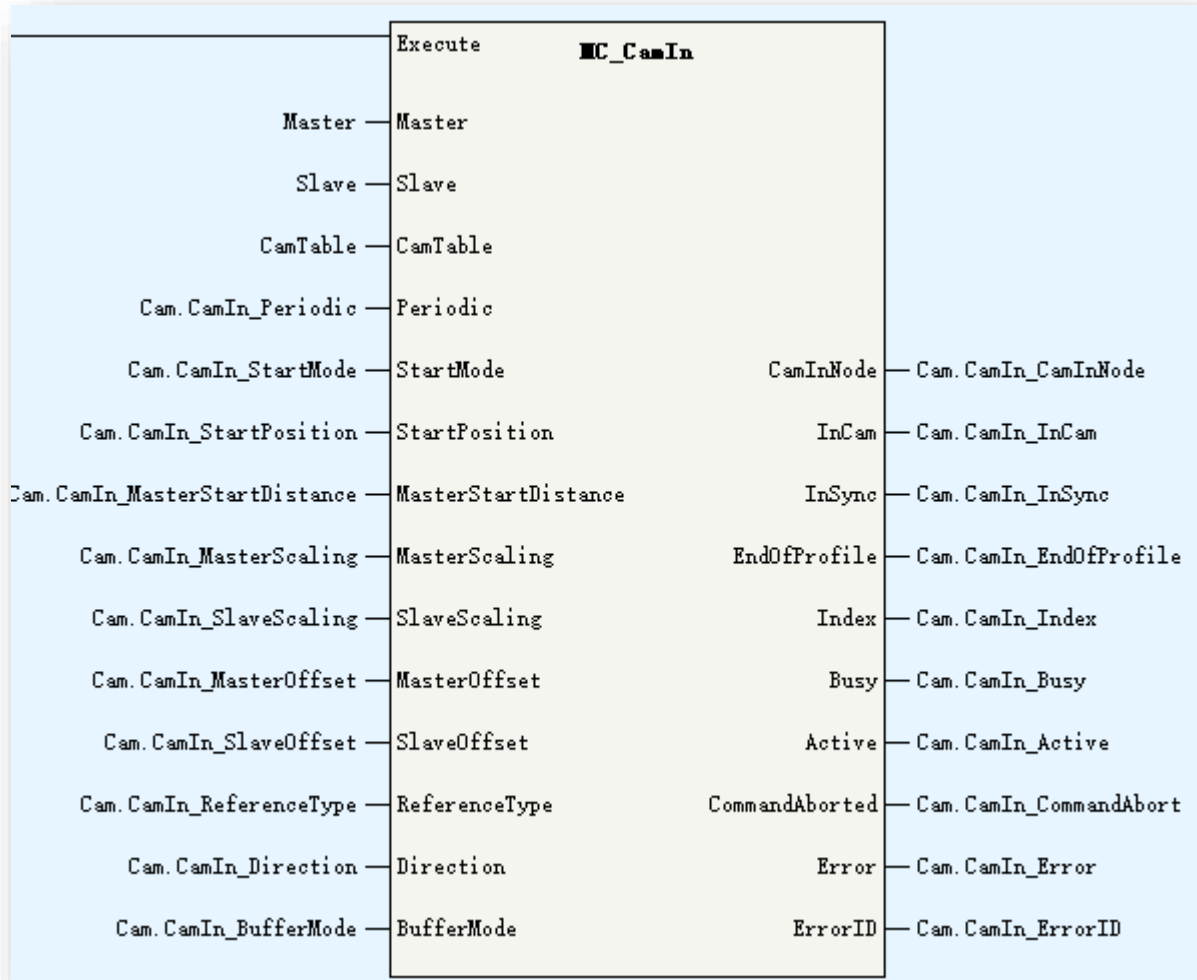

Parameters	Description
Direction	0:positive 1:negative 2:none
BufferMode	0:wait last motion complete Others: reserved
CamInNode	CamIn node(data structure)
InCam	In CAM motion
InSync	In sync motion
EndOfProfile	CAM cycle complete
Index	Index
Active	FB executing

MC_CamIn command can start from standstill, discrete motion, continuous motion and synchronized motion state.

Motion Control(EtherCAT & Pulse Output)

➤ MC_CamIn-CamTable

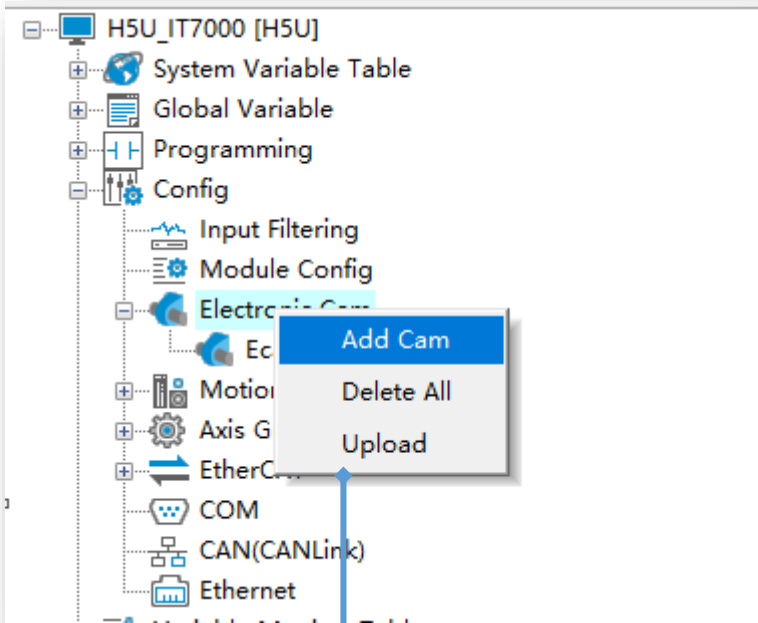

<Config>→<ElectricCam>→right click
<Add Cam> to add a CAM table.
AutoShop support up to **16** CAM tables,
and the H5U PLC support up to **8** CAM
running at the same time. Each CAM
table support **361** key points

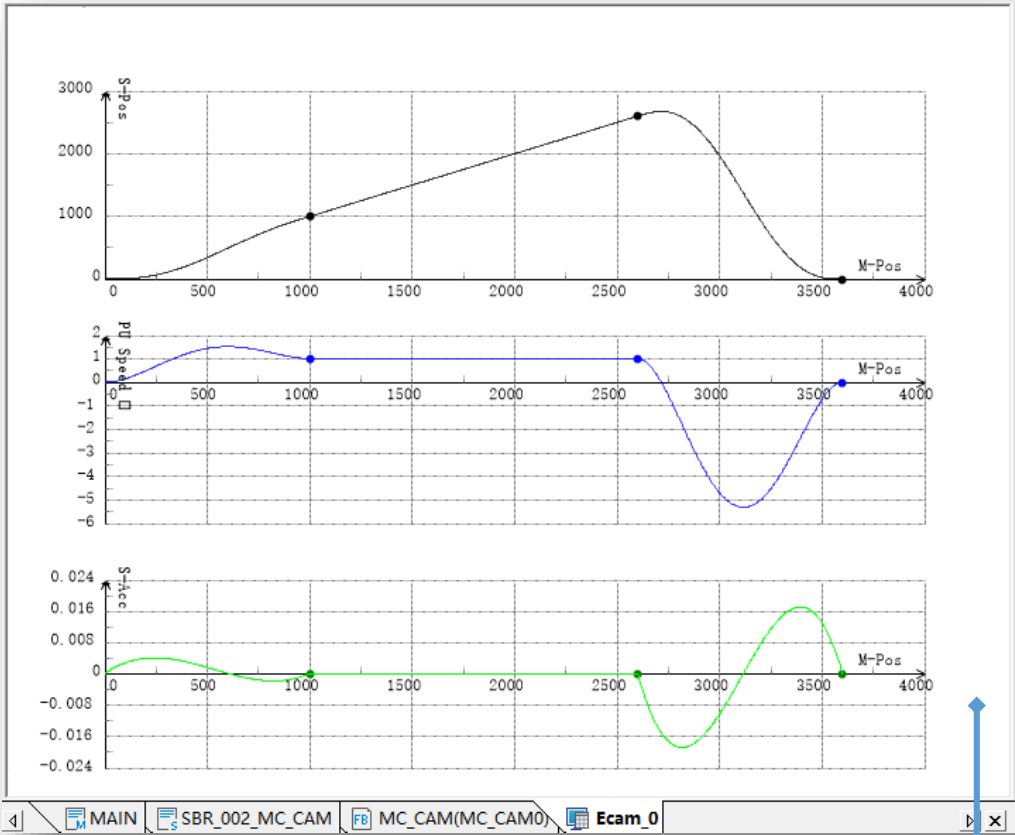

Toolbox

	M-Pos	S-Pos	PV Speed	Type
1	0	0	0	NA
2	1000	1000	1	Spline
3	2600	2600	1	Line
4	3600	0	0	Spline

Drag and drop the key point in the left CAM wiring or
modify the key point data in the right table

CAM table is data collection of master position and slave distance. It describe the position relationship between master and slave. In a CAM motion, controller calculate the slave position according to the CAM table. CAM table can only created by configuration.

Motion Control(EtherCAT & Pulse Output)

➤ MC_CamIn-CamTable Operation

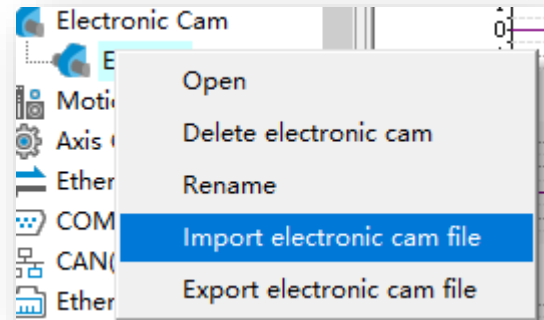

Right click to import/Export CAM file with .CSV format.

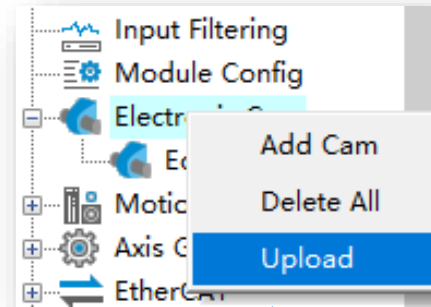

Right click to upload CAM table from PLC

Motion Control(EtherCAT & Pulse Output)

➤ MC_CamIn-StartMode

StartMode=2, CAM start immediately.

From below trace curve, while CamIn enabled, slave get into CAM motion(at this time, slave position is decided by master position, and slave is in synchronized state), at the same time, slave start to move according to CAM table relationship(Insync signal) without delay.

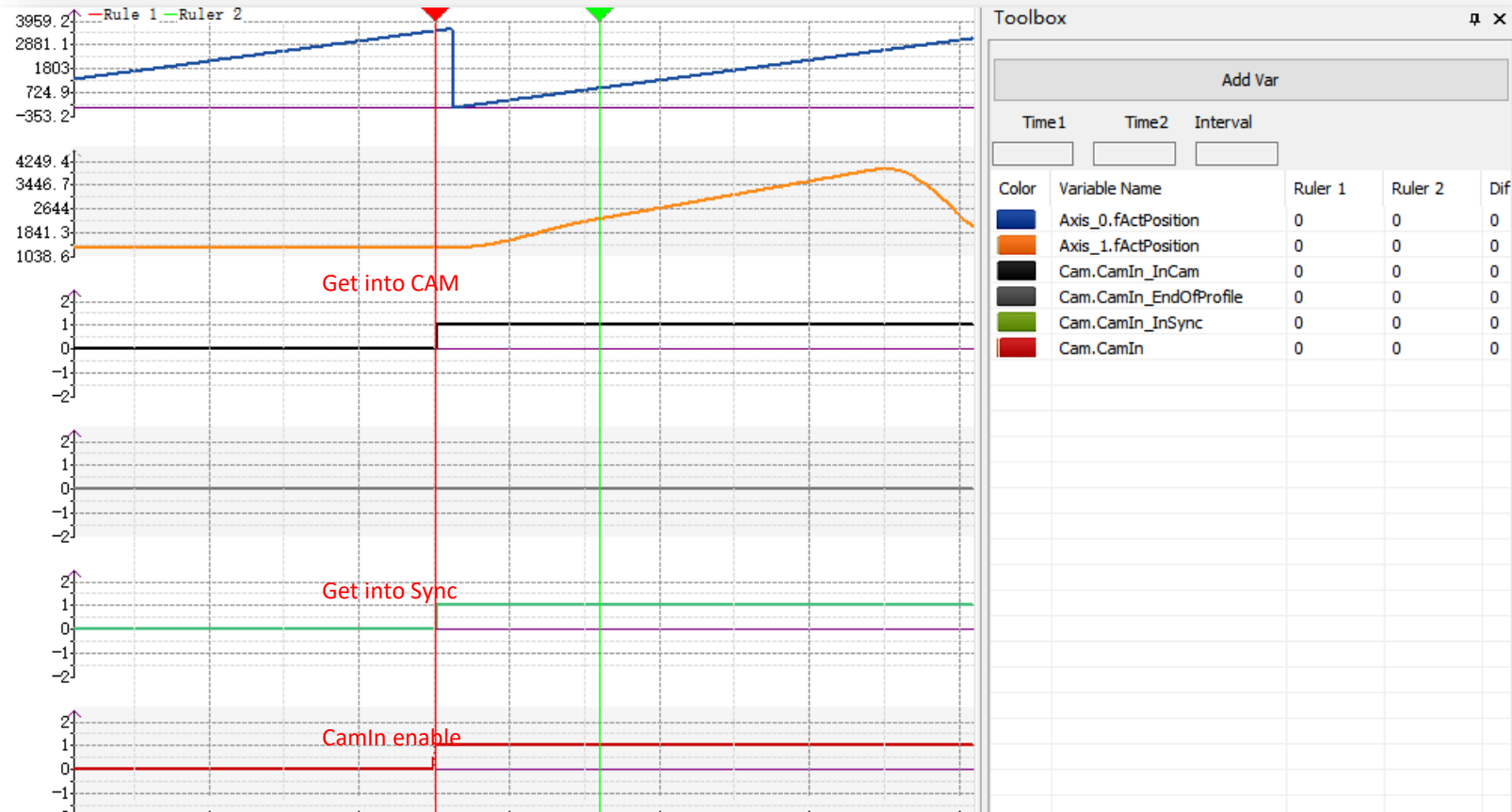

➤ MC_CamIn-StartMode

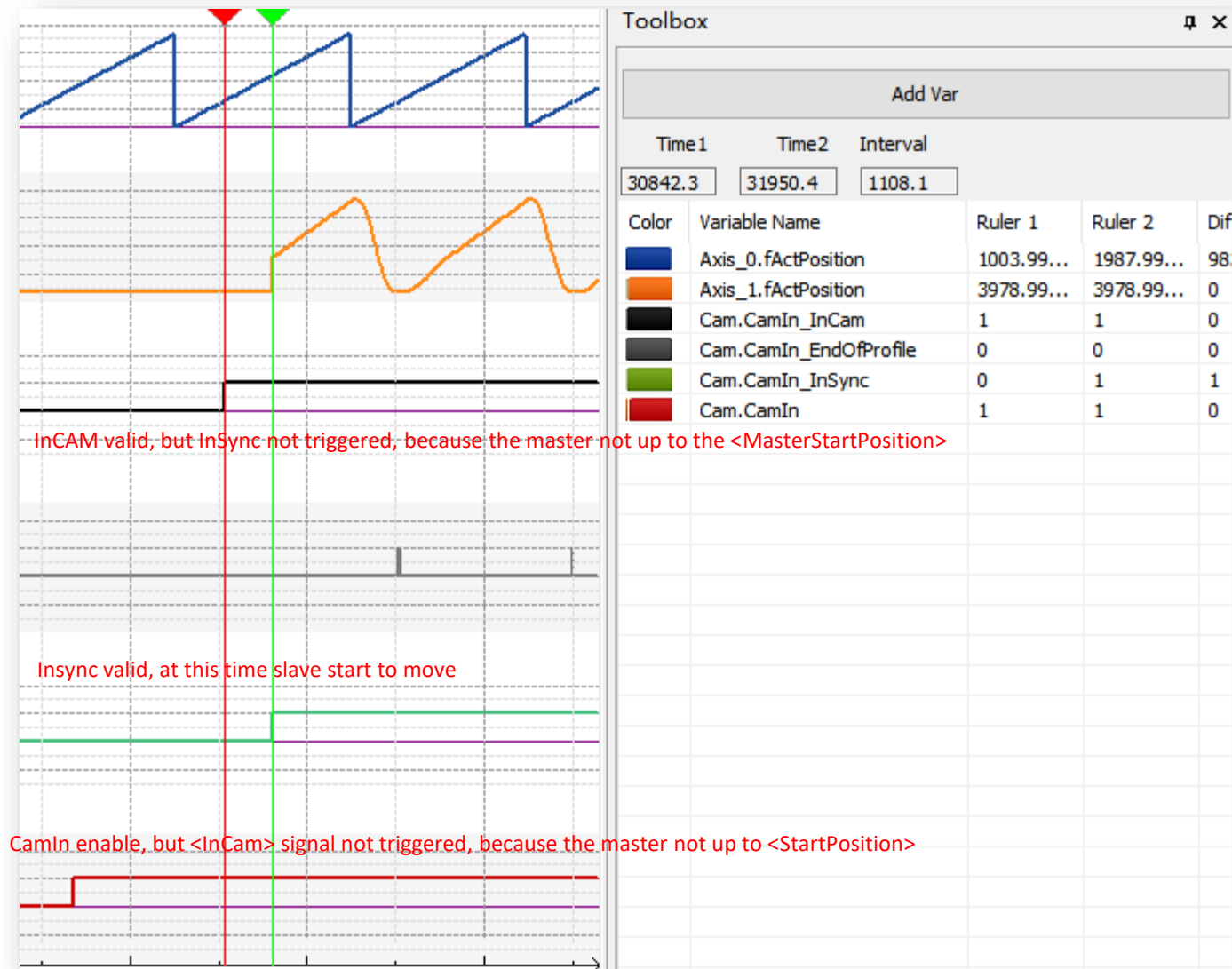

StartMode=0(absolute), CAM start in a specified position. To understand this function, there are 2 parameters need to clarify:

StartPosition: while master position up to startPosition, get into CAM. Be noted <Get into CAM> not mean the slave have to move, it means the slave already create CAM relationship with master.

MasterStartPosition: While master position up to MasterStartPosition, get into Sync. <Get into Sync> means the slave will motion with master according to CAM table(master position). See left trace curve.

While talking about <StartPosition> and <MasterStartPosition>, the value is affected by the <StartMode>, while StartMode=0, the real value:
 StartPosition=<StartPosition>
 MasterStartPosition=<MasterStartPosition>

While StartMode=1, the real value:
 StartPosition=<StartPosition>
 MasterStartPosition=<StartPosition> + <MasterStartPosition>

Motion Control(EtherCAT & Pulse Output)

➤ MC_CamIn-StartMode

Below is the parameters of the former curve, you can see the <InCam> and <InSync> triggered in master position 1000 and 2000:

MC_CamIn			
ON	Execute	InCam	ON
0	Periodic	InSync	ON
0	StartMode	EoP	OFF
1000.0	StartPos	Busy	ON
2000.0	MasterStartDis	Active	ON
1.0	MasterScale	CMDAbort	OFF
1.0	SlaveScale	Error	OFF
0.0	MasterOffset	ErrorID	0
0	SlaveOffset		
1	RefType		
0	Direction		
0	BufferM		

MC_CamOut			
OFF	Execute	ErrorID	
0.0	Dec	0	
0	CurveType		

Time1	Time2	Interval
30842.3	31950.4	1108.1

Color	Variable Name	Ruler 1	Ruler 2	Dif
Blue	Axis_0.fActPosition	1003.99...	1987.99...	98.
Orange	Axis_1.fActPosition	3978.99...	3978.99...	0

If we modify the StartMode=1(relative), other parameters not change, the effect show as below, the <InCam> and <InSync> triggered in master position 1000 and 3000(1000+2000)

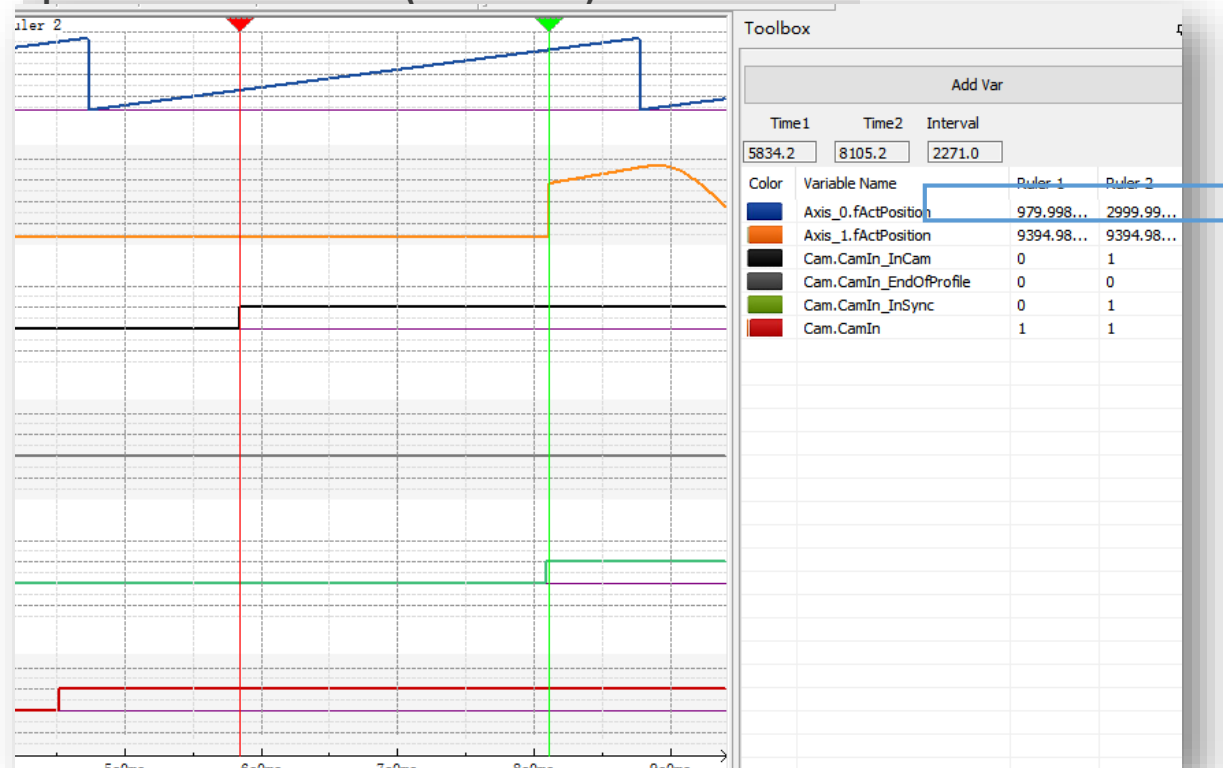

Motion Control(EtherCAT & Pulse Output)

➤ MC_CamIn-StartMode

Be noted while <InCam> position(StartPosition) and <InSync> position(MasterStartPosition) is different, there could be a position jump of slave. If don't want this jump, please make sure the StartPosition=MasterStartPosition(in other word, the <InCam> and <InSync> triggered at the same time). For example, while StartMode=0(absolute) and StartPostion = MasterStartPosition=1000, the effect show as right, the slave position no jump(right image, yellow curve).

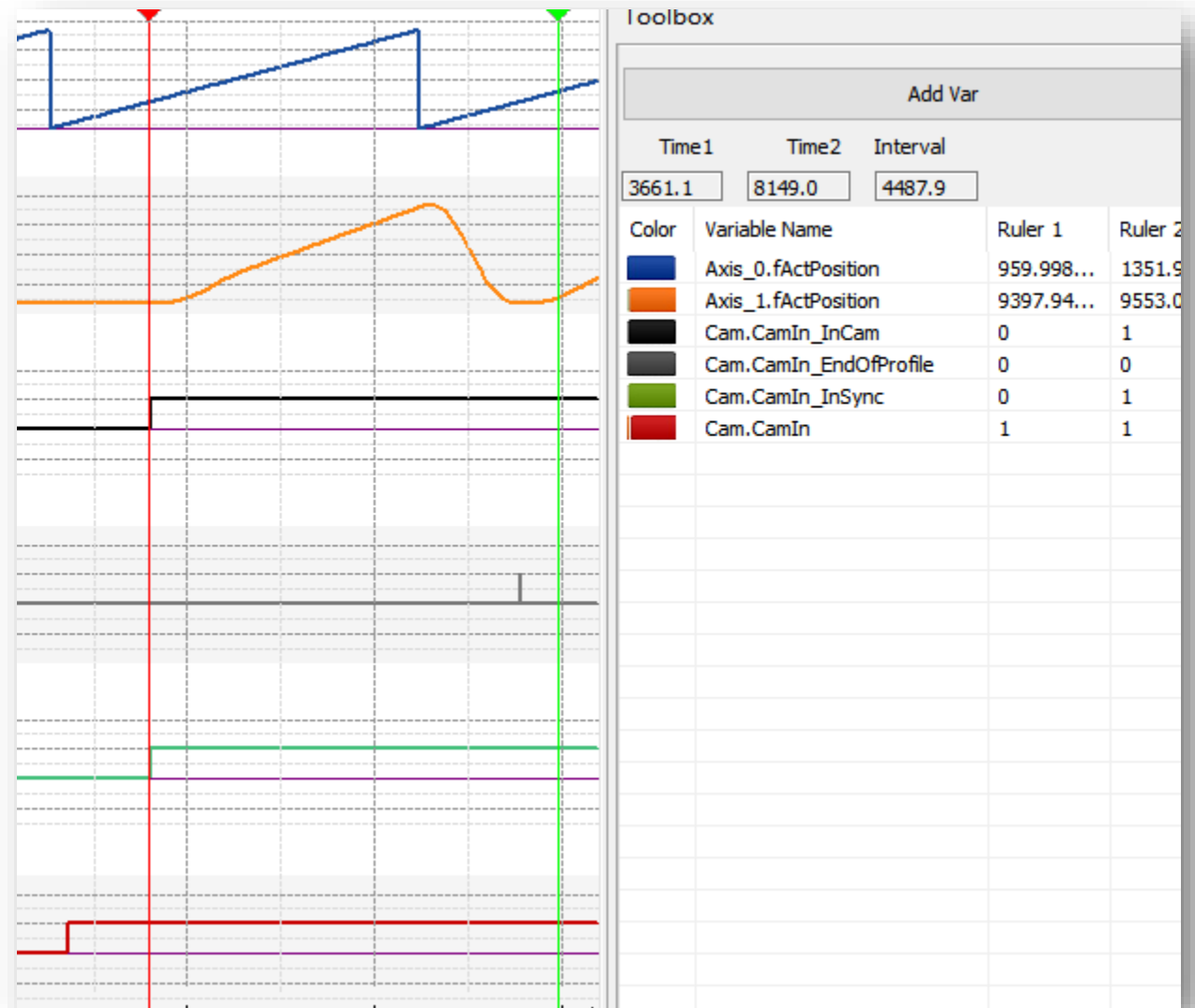

➤ MC_CamIn-Periodic

While Periodic=0, slave axis execute CAM motion repeatedly. <EndofProfile> will triggered and be valid for one cycle time while CAM cycle complete.

While Periodic=N(N>0), axis execute CAM motion N times. <EndofProfile> will triggered and be valid for one cycle time while CAM cycle complete. At the last CAM cycle, <EndOfProfile> will keep valid if Execute is ON.

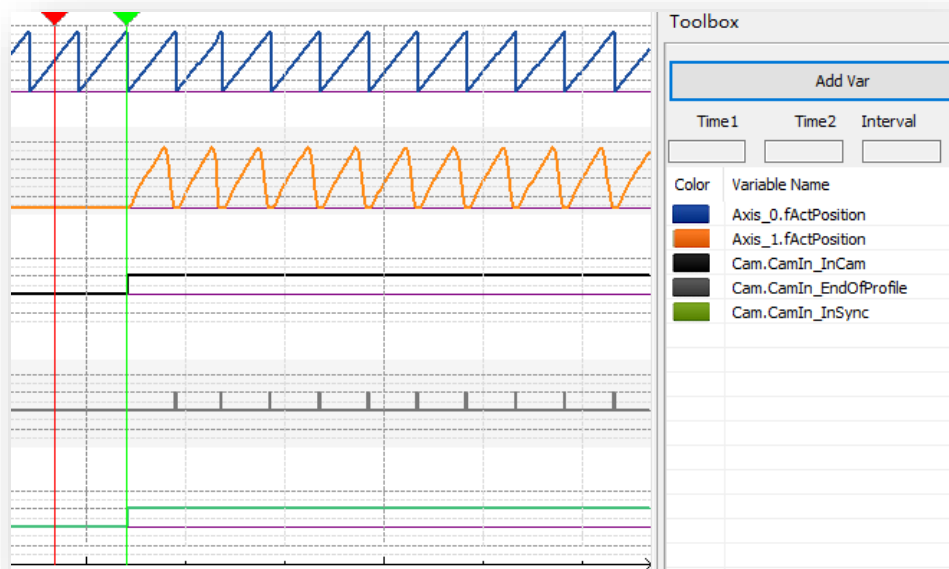

Periodic=0

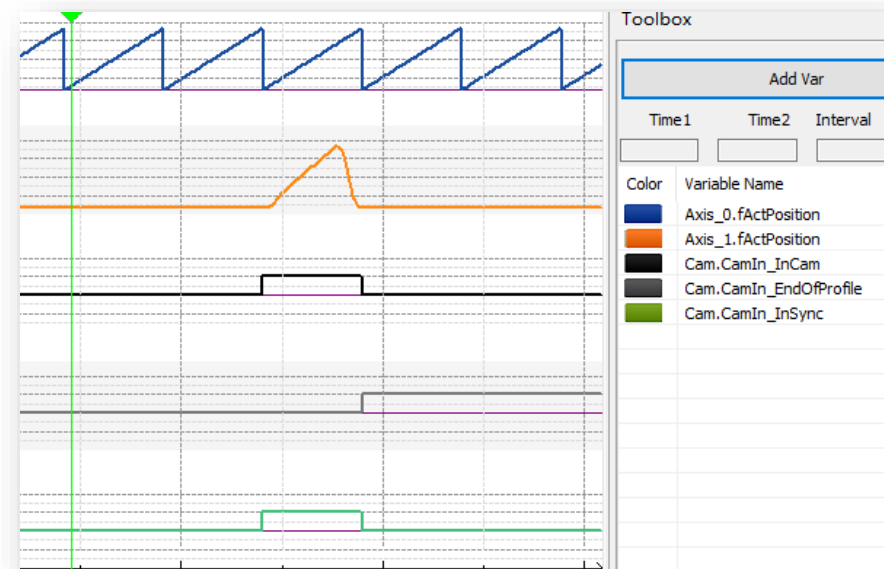

Periodic=1

Motion Control(EtherCAT & Pulse Output)

➤ MC_CamIn-Scale

Scale is used to scale up and down the master position and slave position.
The parameter <MasterScaling> and <SlaveScaling> used to set the ratio.

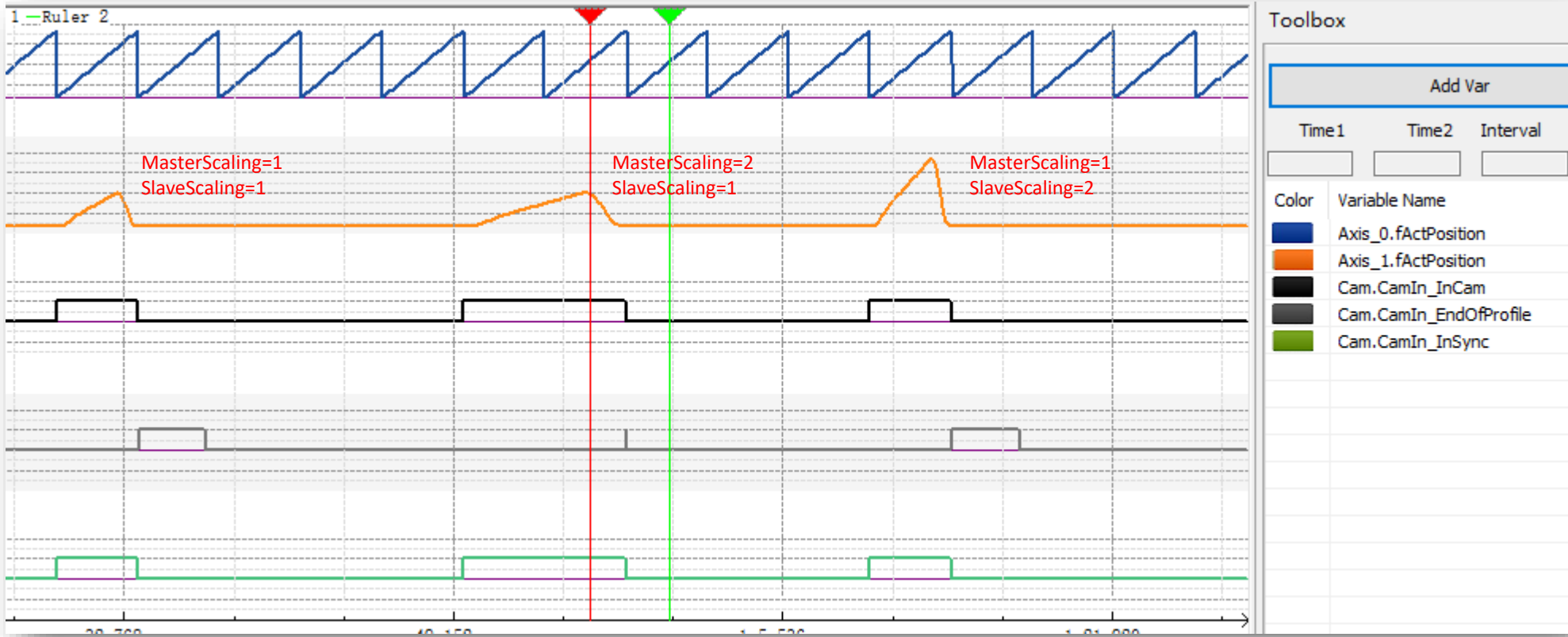

Motion Control(EtherCAT & Pulse Output)

➤ MC_CamIn-Offset

Offset is used to set offset distance for master position and slave position.
The parameter <MasterOffset> and <SlaveOffset> used to set the value.

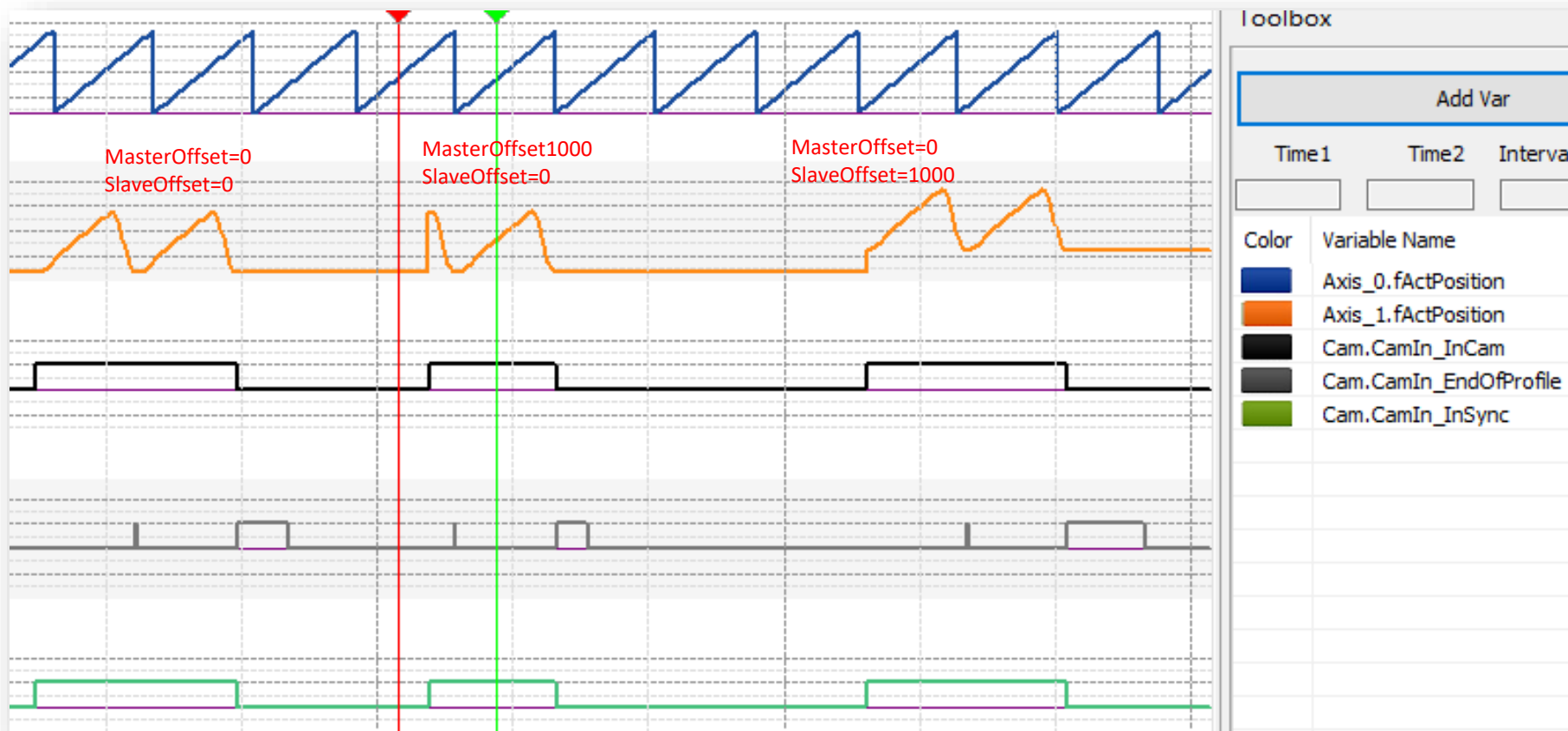

Motion Control(EtherCAT & Pulse Output)

➤ MC_CamIn-Direction

Only when master motion direction same as <Direction>, the slave CAM motion can be enabled. If the master motion direction reversed, the slave will stop motion, until master restore the former direction and position, the slave will continue to move. If there is no specified direction(Direction=2), CAM support move in both direction.

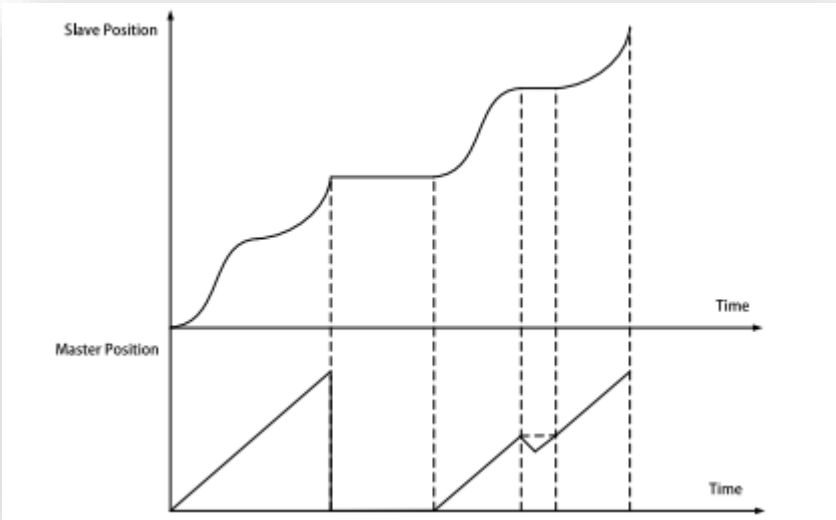
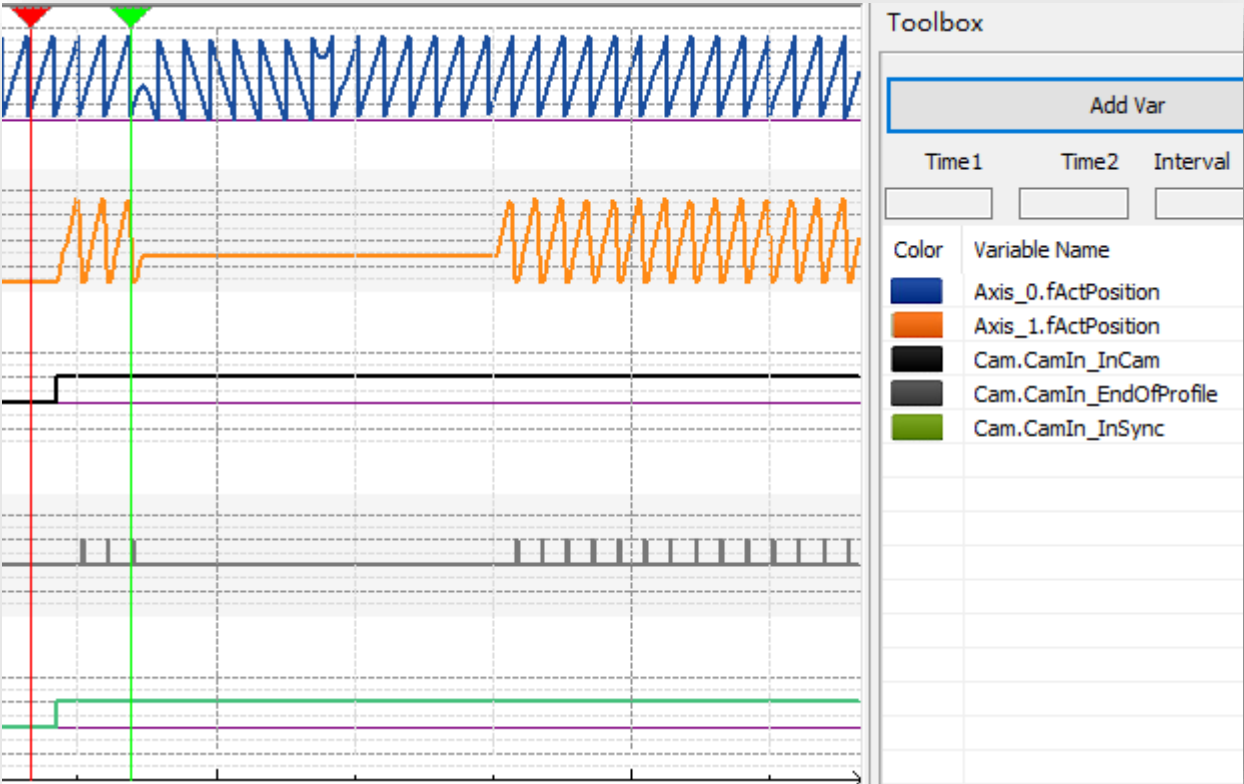

➤ MC_CamIn-Restart and Multi-Start

Re-execute MC_CamIn during FB busy period, <Periodic>/<MasterScaling>/<SlaveScaling>/<ReferenceType>/<Direction> will be refresh and valid in next CAM cycle.

Multi execute MC_CamIn command, the second command busy signal will be valid, but active will not be triggered immediately, need wait the current running CAM cycle complete, the new command active become valid. Then, the second CAM will work and <Periodic>/<MasterScaling>/<SlaveScaling>/<ReferenceType>/<Direction> parameters will follow the newer command.

➤ MC_CamOut

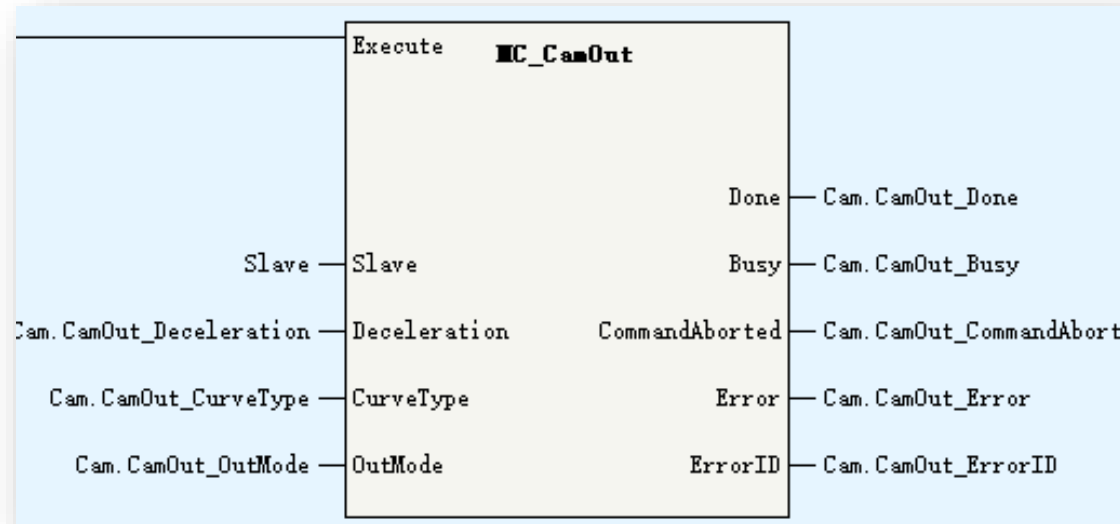

Parameters	Description
Slave	Slave Axis Name
Deceleration	Deceleration
CurveType	Velocity ACC/DEC curve: 0: T curve
OutMode	0: deceleration to stop 1: after current CAM cycle complete, stop immediately

MC_CamOut is used to release the CAM motion of slave.

If OutMode=0, while execute this FB, slave axis will get into continuous motion and deceleration to stop(standstill)

If OutMode=1, while execute this FB, slave will still in CAM motion(synchronized motion state) until current CAM cycle complete, after that, slave stop immediately.

➤ MC_GetCamTablePhase

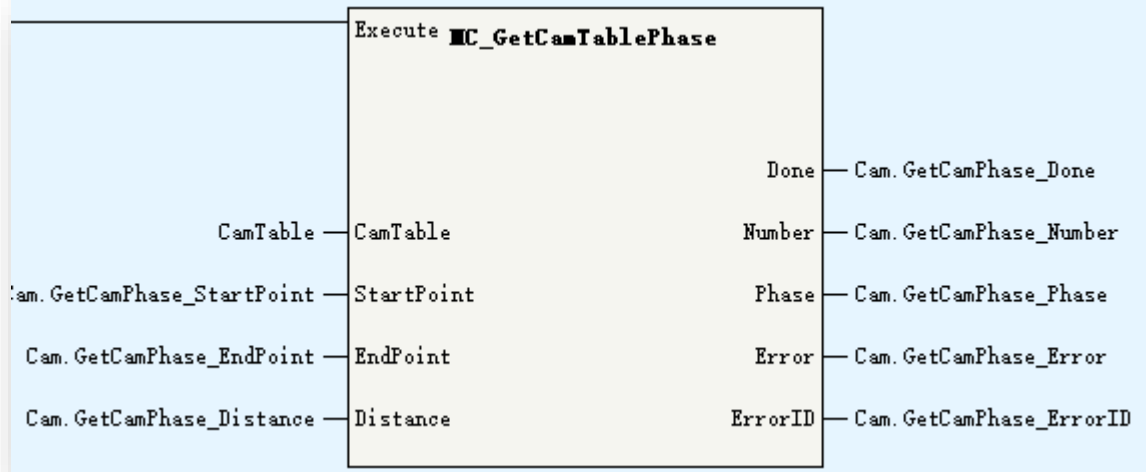

Parameters	Description
CamTable	Cam table
StartPoint	Start Point (_sMC_CAM_NODE)
EndPoint	End Point (_sMC_CAM_NODE)
Distance	Slave position in CAM
Number	Corresponding master position -1: infinite same position 0:None Greater than 0: the actual position quantities
Phase	The actual master position(array)

sMC_CAM_Node	Description
fPhase	Master phase
fDistance	Slave distance
fVel	Connection velocity
fAcc	Connection acceleration(reserved)
iCurve	Curve Type 0: reserved 1: linear 2: quintic curve

MC_GetCamTablePhase is used to calculate the master position according to slave position within 2 CAM key points(sMC_CAM_NODE).

Motion Control(EtherCAT & Pulse Output)

➤ MC_GetCamTableDistance

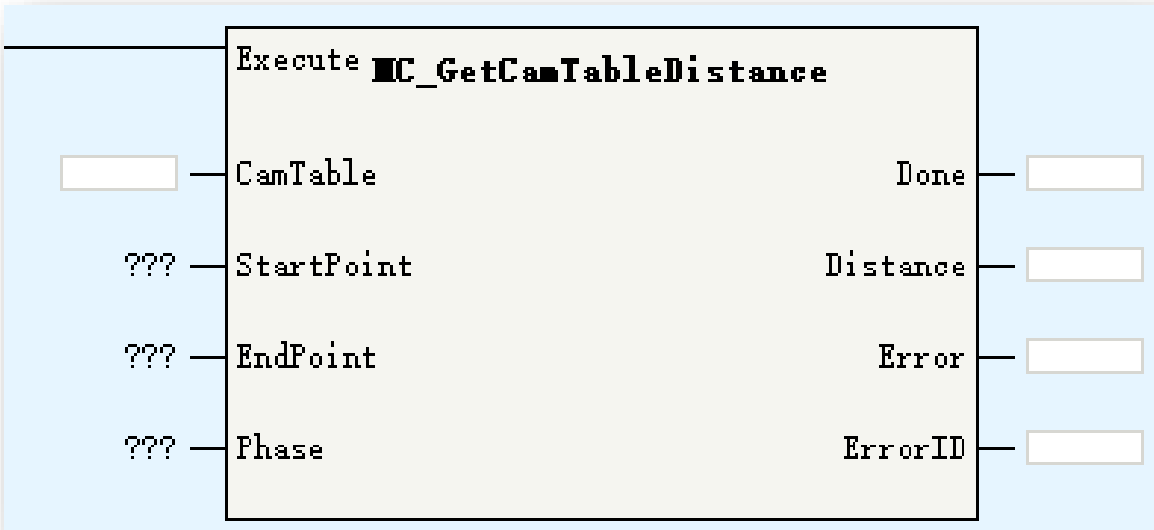

Parameters	Description
CamTable	Cam table
StartPoint	Start Point (_sMC_CAM_NODE)
EndPoint	End Point (_sMC_CAM_NODE)
Phase	Master position in CAM
Distance	Slave position in CAM

sMC_CAM_Node	Description
fPhase	Master phase
fDistance	Slave distance
fVel	Connection velocity
fAcc	Connection acceleration(reserved)
iCurve	Curve Type 0: reserved 1: linear 2: quintic curve

MC_GetCamTableDistance is used to calculate the slave position according to master position within 2 CAM key points(sMC_CAM_NODE).

➤ MC_SaveCamTable

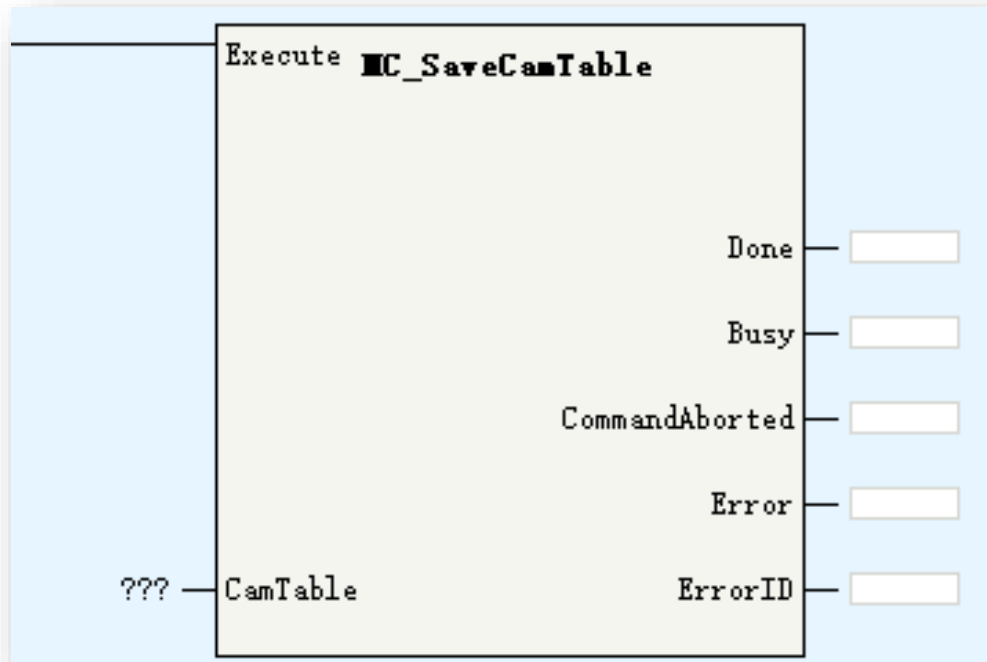

Parameters	Description
CamTable	Cam table

MC_SaveCamTable is used to save the specified CAM table to flash. Be noted while this command executing, cannot power off the controller, or the CAM data will lost.

Motion Control(EtherCAT & Pulse Output)

➤ MC_GenerateCamTable

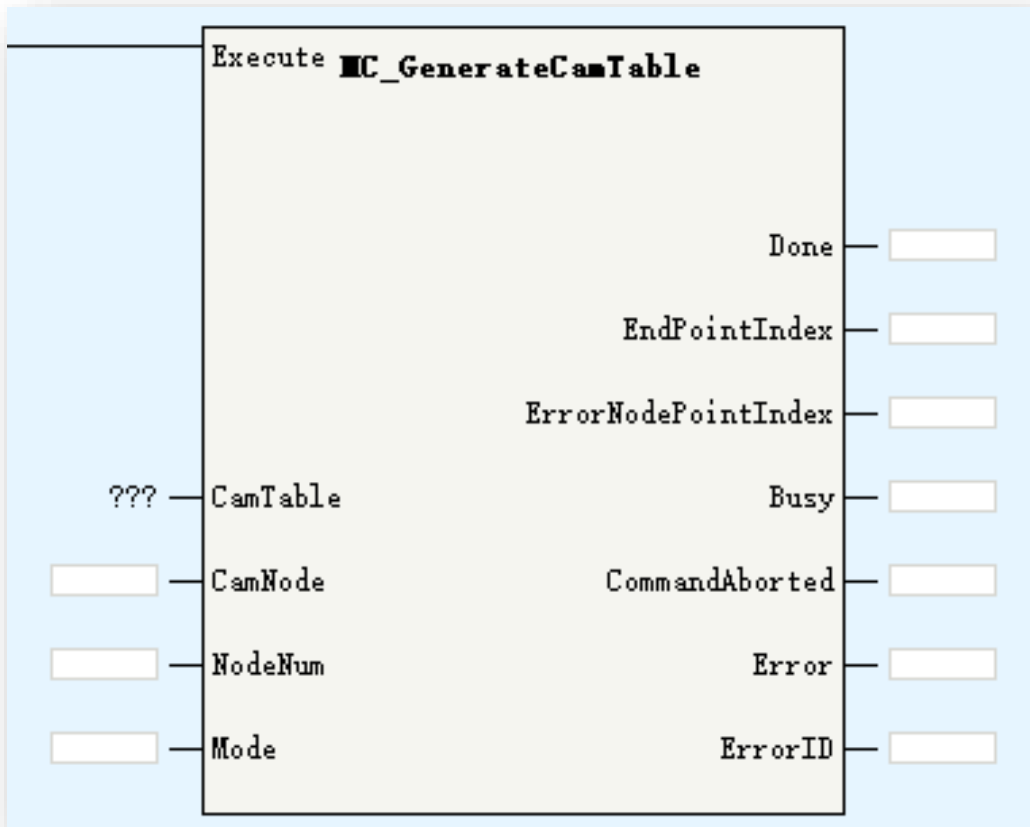

MC_GenerateCamTable is used to update the specified CAM table data according to <CamNode> and <NodeNum>, the updated CAM table will effect in next CAM cycle.

Parameters	Description
CamTable	Cam table
CamNode	CAM node array (_SMC_CAM_NODE)
NodeNum	CAM node number, 2~361. While this parameter is empty, using the mode number of current CAM table
Mode	0: valid in next CAM cycle
EndPointIndex	End point index
ErrorNodePointIndex	Error point index

sMC_CAM_Node	Description
fPhase	Master phase
fDistance	Slave distance
fVel	Connection velocity
fAcc	Connection acceleration(reserved)
iCurve	Curve Type 0: reserved 1: linear 2: quintic curve

➤ MC_GenerateCamTable-CamNode

<CamNode> is used to specify if the new CAM point array will be used. While <CamNode> is empty, the former CAM point array will be used and user only modify the key points value. While <CamPoint> is not empty (and range is 2~361), the new CAM point array will be used and users have to set all key points value.

Below table show the process while <CamNode> is empty:

Master	Slave
0	0
500	500
2600	2600
3600	0

Modify key point(s) in same node array

Master	Slave
0	0
1000	1000
2600	2600
3600	0

```

[ DEMOV E1000 Ecam_0.sCamnode[1].fPhase
  Spindle Phase (Writable) ]
[ DEMOV E1000 Ecam_0.sCamnode[1].fDistance
  Displacement from axis (writable) ]
[ DEMOV E0 Ecam_0.sCamnode[1].fVel
  Connection speed (writable) ]
[ MOV K4 Cam.GenCamTable_NodeNum ]
[ SET Cam.GenCamTable ]
    
```

Motion Control(EtherCAT & Pulse Output)

➤ MC_GenerateCamTable-CamNode

Below table show the process while <CamNode> is not empty:

Master	Slave
0	0
500	500
2600	2600
3600	0

Create a new node array

Master	Slave
0	0
500	500
1000	1000
2600	2600
3000	3000
3300	3200
3600	0

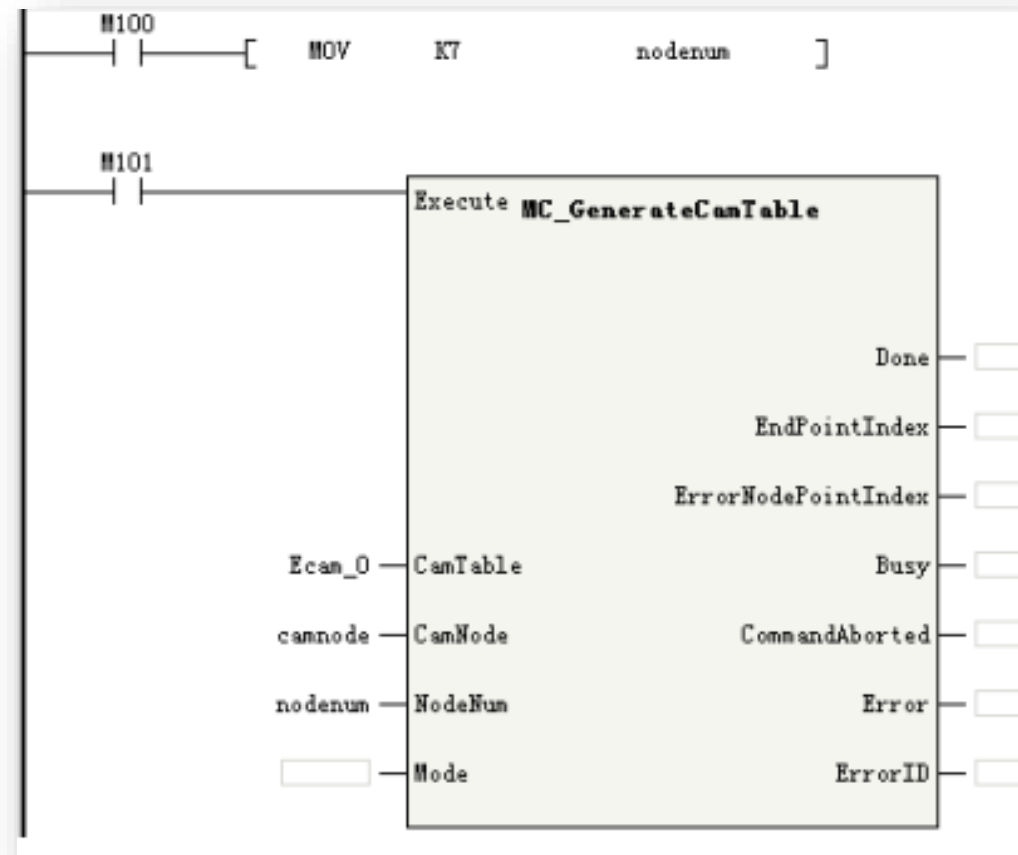

Motion Control(EtherCAT & Pulse Output)

➤ MC_DigitalCamSwitch

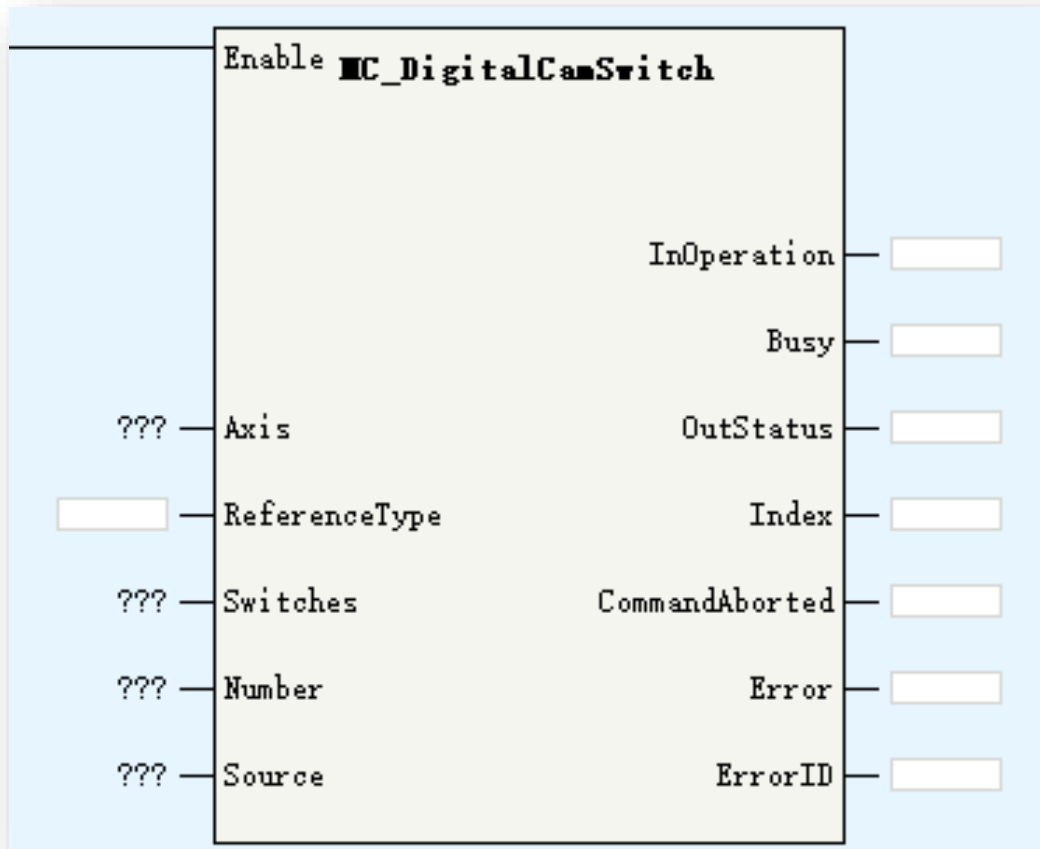

Parameters	Description
Axis	Axis ID/Axis name
ReferenceType	Reference position: 0: last cycle set position 1: current cycle set position 2:current cycle feedback position 3: while <Axis> as CAM slave, the master position
Switches	Tappet switch(_sMC_DigitalSwitch[1..32])
Number	Tappet switch number
Source	Tappet source: 0~13 is the physical output 1000~1007 is the virtual output
InOperation	In tappet
OutStatus	Out status
Index	Index of comparison point to be executed, 0~31

MC_DigitalCamSwitch used to reality CAM tappet function. The <Switch> used to set the configuration of tappet switch and the <Source> used to set the output tappet signal.

Motion Control(EtherCAT & Pulse Output)

➤ MC_DigitalCamSwitch

_sMC_DigitalSwitch	Description
fPosition	Start absolute position of tappet valid range
iMode	Switch mode: 0: disabled 1: position type 2: time type
iDirection	Master direction 0:positive 1:negative 2:none
fParameter	Positon type: end position of tappet valid range Time type: time(ms) for output valid, not over 10000ms

fPosition	iMode	iDirection	fParameter
500	1	0	1000
1100	1	0	1300
1500	1	0	2000
2500	2	0	100

Take note:

iMode=0, do not use current comparison point

iMode=1, while master up to <fPosition>, output valid, and while master up to <fParameter>, output invalid

iMode=2, while master up to <fPosition>, output valid, after <fParameter> ms, output invalid

The start position have to be different with end position

In the switch array, the <fPosition>(start position) of each switch is unique, which means, if over 2 switch share same start position, the error will occur.

In the right table, we set the switches.

Motion Control(EtherCAT & Pulse Output)

➤ MC_DigitalCamSwitch

The real effect in trace curve.

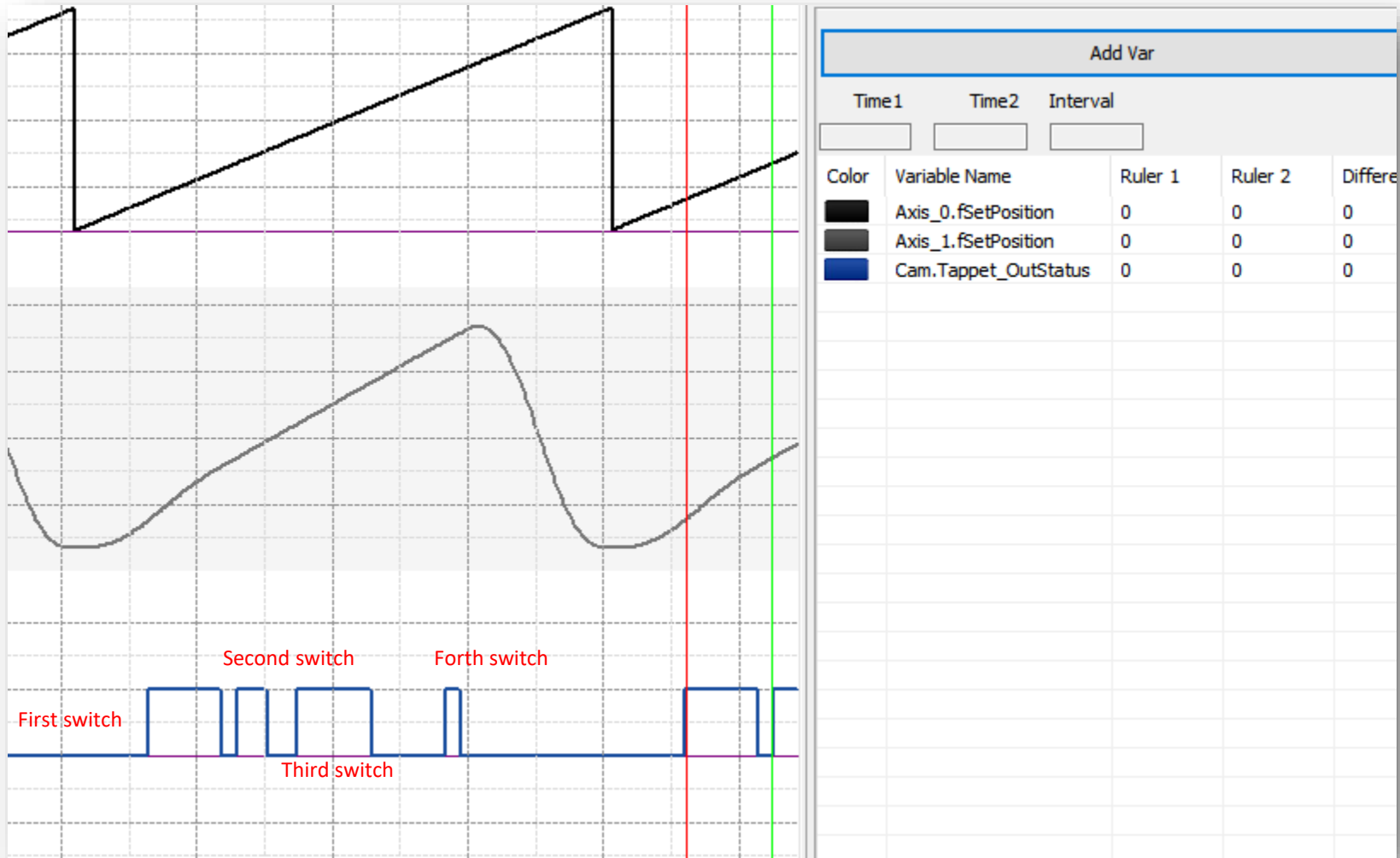

Motion Control(EtherCAT & Pulse Output)

➤ MC_GearIn

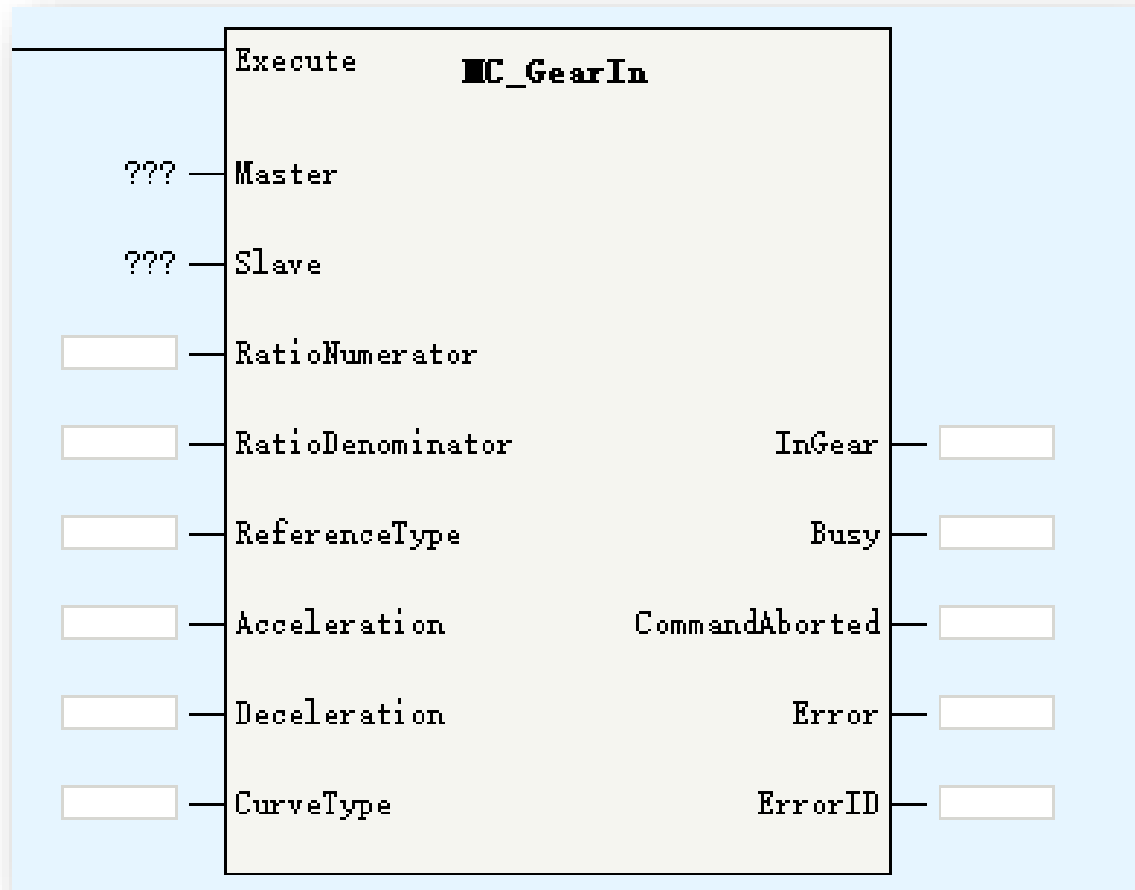

Parameters	Description
Master	Master axis: support EtherCAT axis, pulse control axis, Fieldbus encoder axis and local encoder axis
Slave	Slave axis: support EtherCAT axis and pulse control axis
RatioNumerator	Numerator of gear ratio
RatioDenominator	Denominator of gear ratio
ReferenceType	0: last cycle set position 1: current cycle set position 2:current cycle feedback position
Acceleration	Acceleration
Deceleration	Deceleration
CurveType	Curve type 0: T type curve
InGear	In gear

MC_GearIn is used to establish velocity relationship between 2 axis. The slave axis velocity will follow the master axis velocity according to the gear ratio. MC_GearIn support restart or multi start to update gear ratio.

Motion Control(EtherCAT & Pulse Output)

➤ MC_GearIn

Take note:

To get stable slave velocity, H5U provide filter function for MC_GearIn function to filter the master velocity. The calculation principle as below:

Filter Master velocity= $fFilter[0]*CurrentCycleMasterVelocity + fFilter[1]*LastCycleMasterVelocity + fFilter[2]*TheTimeBeforeLastCycleMasterVelcity$. In other word, it is a weighted calculation of recent 3 cycles master velocity. The fFilter[0..2] parameters is in axis structure, users can invoke these parameters by <AxisName>.fFilter[0..2] to set the filter parameters. Make sure the summary of fFilter[0..2] is 1.

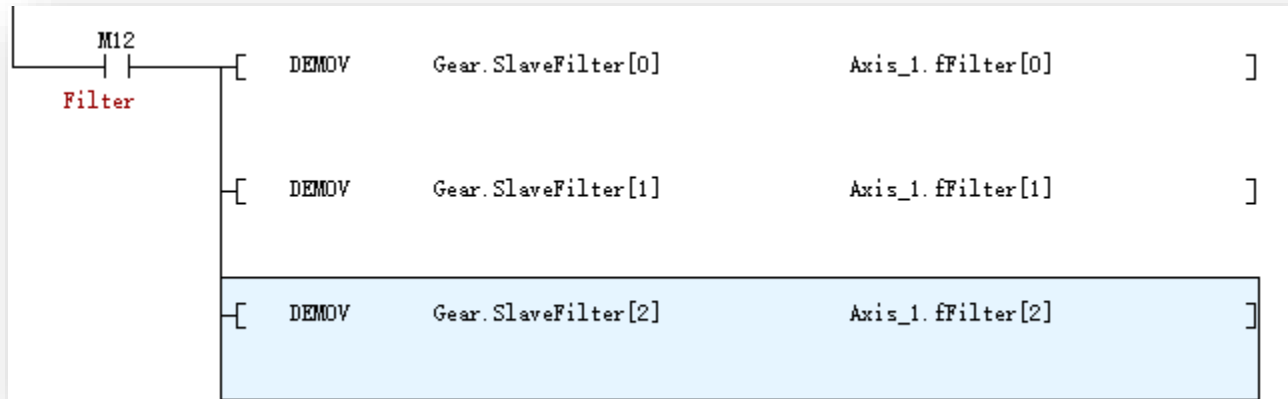

fFilter	REAL[3]		Set the filter factor for the spindle (power-on ini..
fFilter[0]	REAL	Dec	
fFilter[1]	REAL	Dec	
fFilter[2]	REAL	Dec	

Motion Control(EtherCAT & Pulse Output)

➤ MC_GearOut

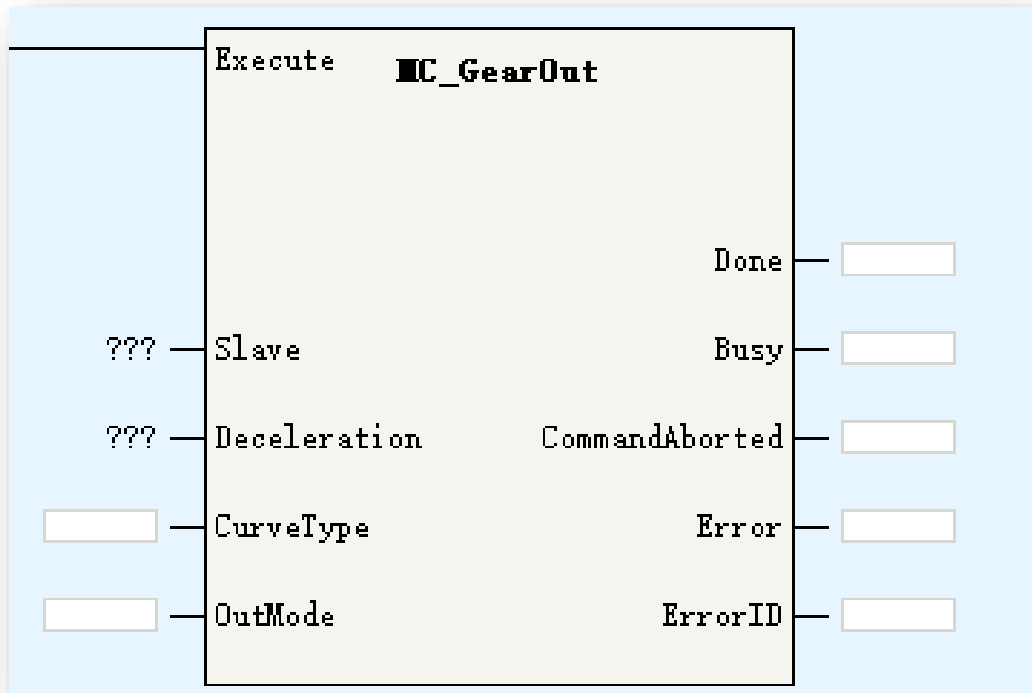

Parameters	Description
Slave	Slave axis: support EtherCAT axis and pulse control axis
Deceleration	Deceleration
CurveType	Curve type 0: T type curve
OutMode	0: Deceleration to stop

MC_GearOut is used to release the gear motion of slave.

➤ MC_Phasing

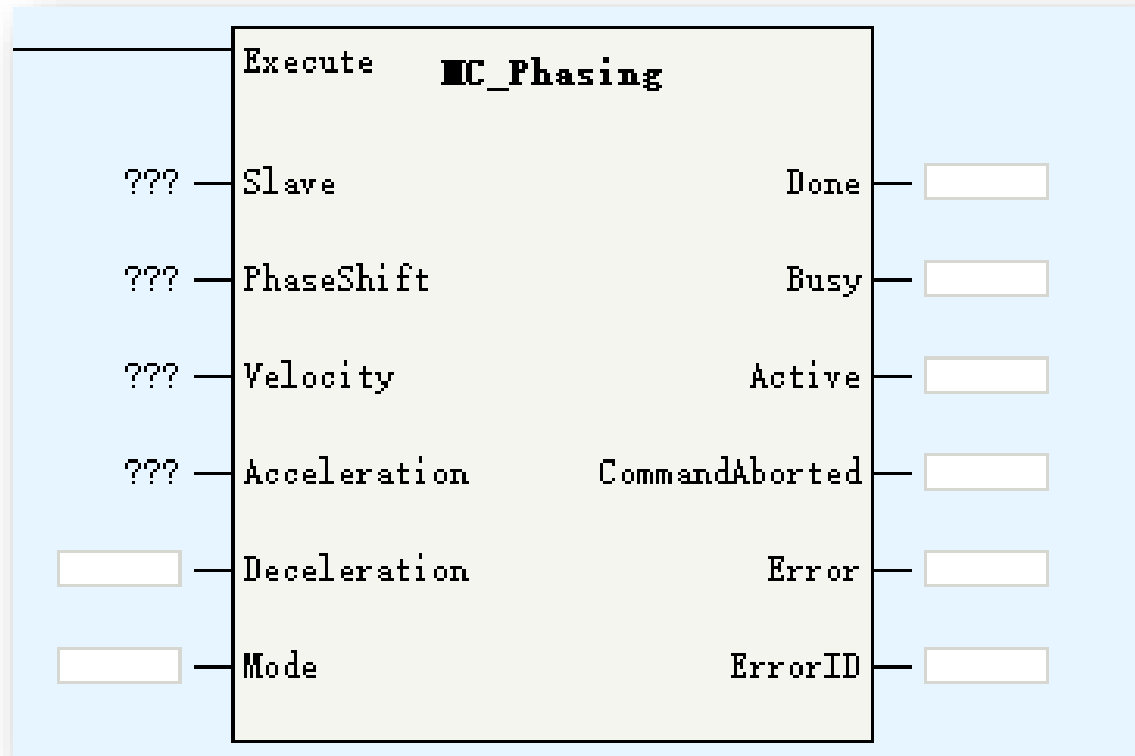

Parameters	Description
Slave	Slave Axis ID/Axis name
PhaseShift	Master offset value
Velocity	Target velocity
Acceleration	Acceleration
Deceleration	Deceleration
Mode	Mode: 0: reserved 1: Stop phase shift while master velocity is 0
Active	Compensation executing

MC_Phasing is used to set the master offset in CAM or GEAR motion. Be noted this command will not impact the position of master, but impact the position(origin set position + calculated offset position) of slave.

Motion Control(EtherCAT & Pulse Output)

➤ MC_Phasing-while using with CAM motion

While using with MC_CamIn, if MC_Phasing enabled before MC_CamIn.Insync signal, it will stay in buffer mode and wait the Insync signal turn ON.

The master position curve will not impact by this command by slave position will change to new position (corresponding position of master position + offset)

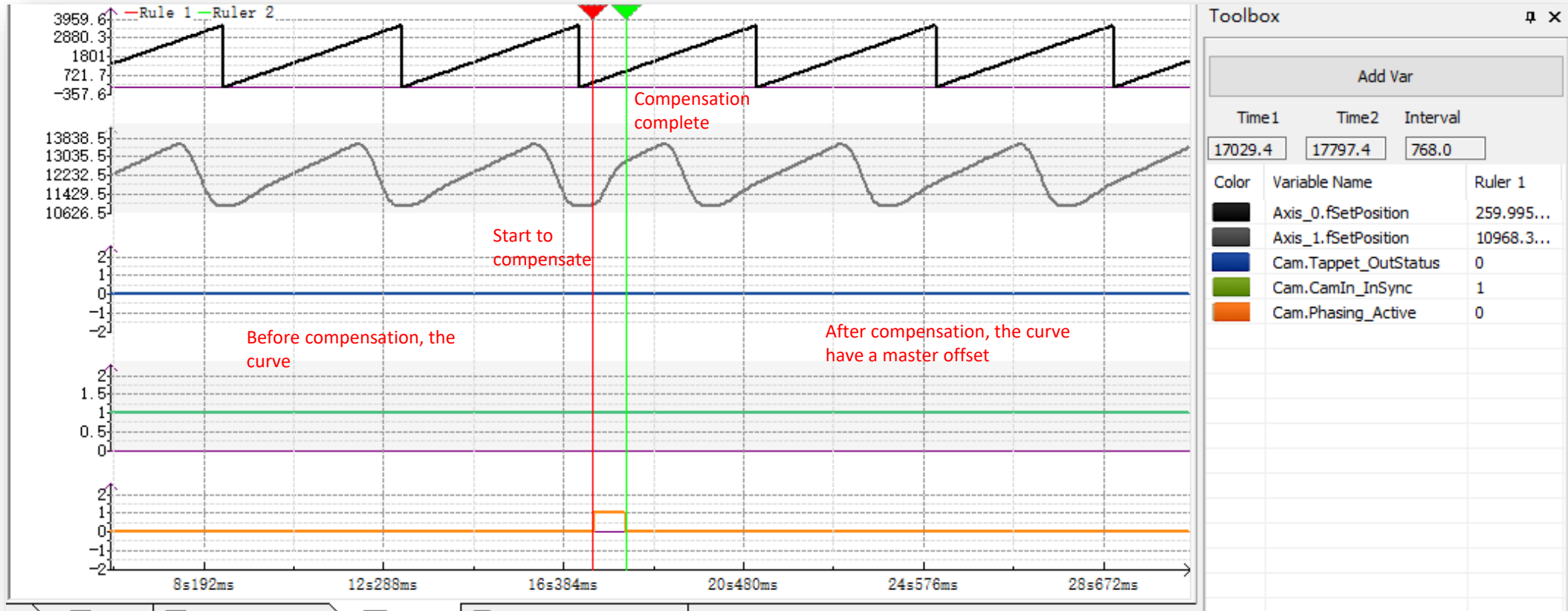

Add Var		
Time1	Time2	Interval
17029.4	17797.4	768.0
Color	Variable Name	Ruler 1
Black	Axis_0.fSetPosition	259.995...
Grey	Axis_1.fSetPosition	10968.3...
Blue	Cam.Tappet_OutStatus	0
Green	Cam.CamIn_InSync	1
Orange	Cam.Phasing_Active	0

Motion Control(EtherCAT & Pulse Output)

[Back to Contents](#)

Axes Group	Function
MC_MoveLinear	Axes group move linear curve
MC_MoveCircular	Axes group move circular curve
MC_GroupStop	Axes group stop
MC_GroupPause	Axes group pause

➤ Interpolation Introduction

H5U support linear interpolation and circular interpolation in a space Cartesian coordinate system. The interpolation function is realized in the form of axes group.

- >Each axes group support up to 4 axes(EtherCAT axis or local pulse axis), include X/Y/Z (coordinate axis) and A (auxiliary axis);
- >H5U support up to 8 axes group, each axes group support 2 axes(X/Y), 3 axes(X/Y/Z) and 4 axes(X/Y/Z/A);
- >Interpolation support buffer mode, each axes group support up to 8 buffer curve, the transition mode is settable.

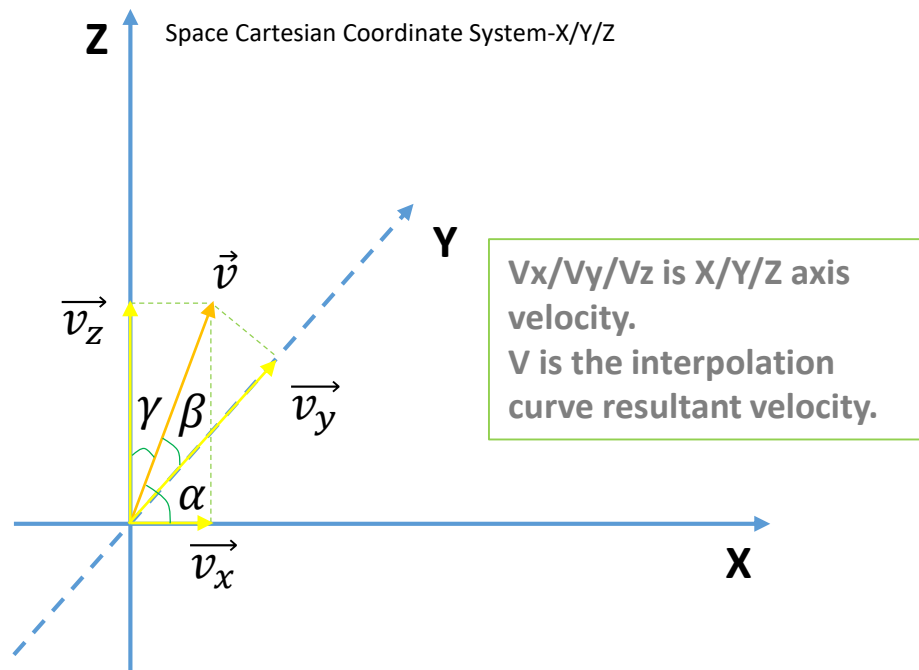

Linear Coordinate System-A

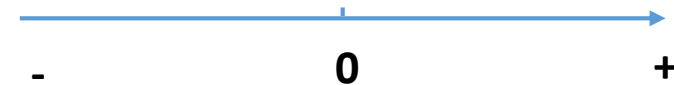

While linear interpolation, X/Y/Z motion in coordinate direction, auxiliary axis move linearly from start point to end point.
 While circular interpolation, select XY/YZ/XZ plane as circular interpolation, other axis move linearly from start point to end point.

Motion Control(EtherCAT & Pulse Output)

➤ Axes Group Configuration-Basic Settings

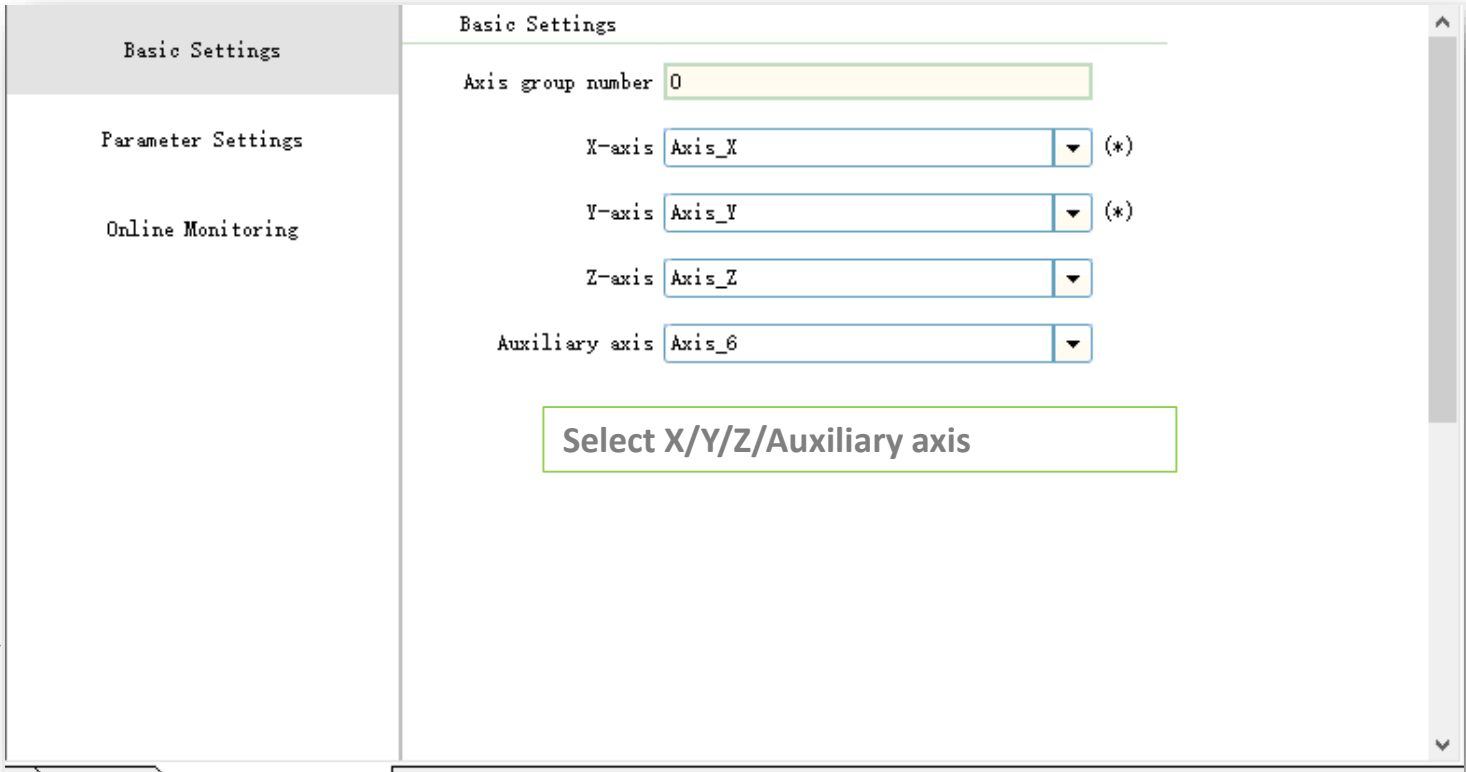
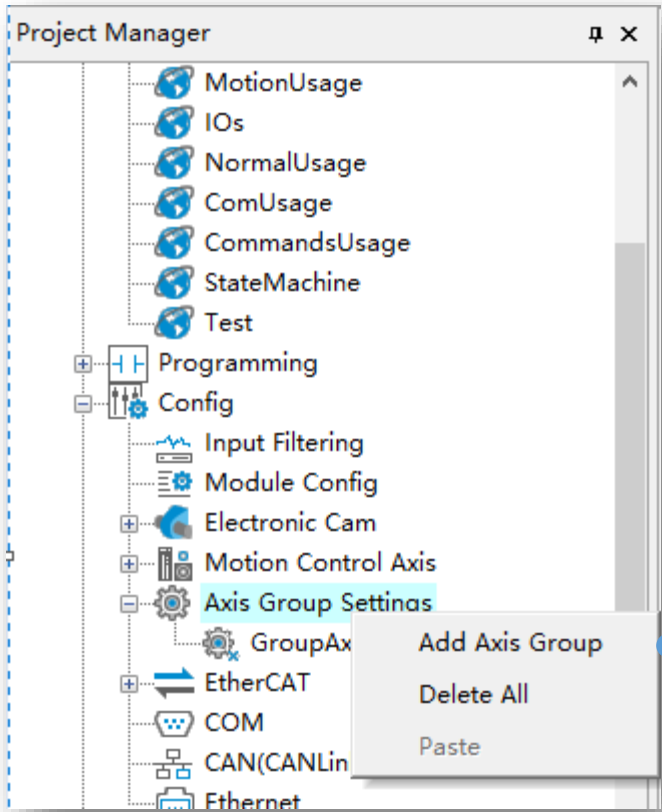

<Project Manager>→<Config>→<Axis Group Settings> right click to <Add Axis Group>

Motion Control(EtherCAT & Pulse Output)

➤ Axes Group Configuration-Parameter Settings

Basic Settings	Parameter Settings	
Parameter Settings	Speed limit	Maximum Speed <input type="text" value="5000.00"/> Unit/s Maximum acceleration <input type="text" value="30000.00"/> Unit/s ²
Online Monitoring	Interpolation parm.	Stop mode <input type="text" value="Stop now"/> ▼

Set maximum speed and maximum velocity. If the interpolation FBs parameters over the limit, the error will occur

Motion Control(EtherCAT & Pulse Output)

➤ Axes Group Configuration-Online Monitoring

Basic Settings	Online Monitor			
Parameter Settings	X-axis	Y-axis	Z-axis	Auxiliary Axis
Online Monitoring	Status	0	0	0
	Fault code	0	0	0
	Set location	0	0	0
	Feedback location	0	0	0
	Set speed	0	0	0
	Feedback speed	0	0	0
	Axis Group			
	Status	0	Fault code	0
	Running distance	0	Remaining distance	0
	Set speed	0	Set accel./decel.	0
	Radius	0	Center of circle	0

To check the parameters and error information for each axis in group

➤ Interpolation Process

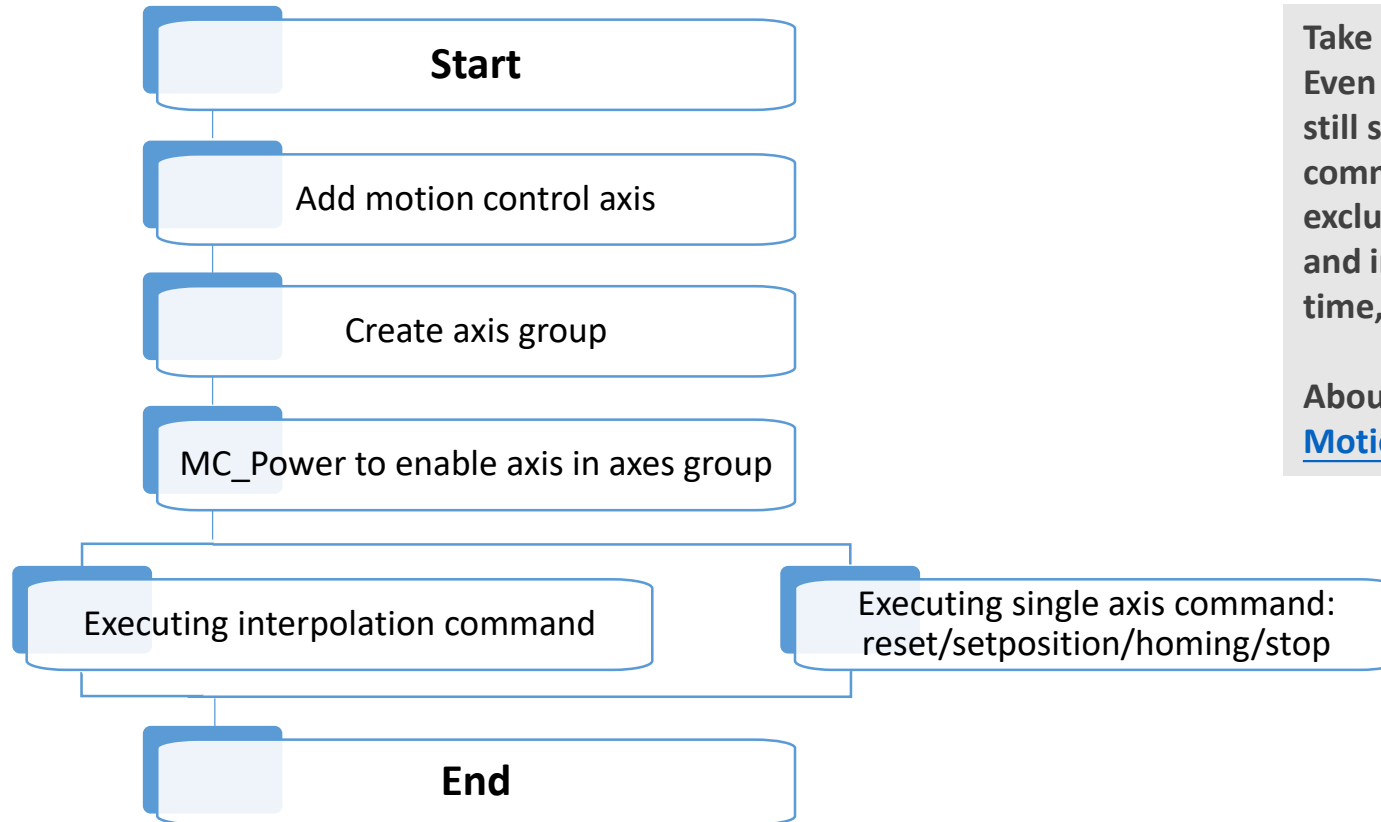

Take note :

Even though an axis is added to an axes group, the axis still support single axis motion. However, the single axis commands and interpolation commands are mutually exclusive, which means, single axis motion commands and interpolation commands will not effect at the same time, and at the same time, they cannot abort each other.

About how to add motion control axis, please refer to [Motion control axis configuration.](#)

Motion Control(EtherCAT & Pulse Output)

➤ Axes Group System Variable

While create an axes group in project configuration, a system structure `_SMC_GroupInfo` will be created automatically. In this data structure, users can monitoring and check the axes group status. Below table only show the `<wState>` definition, more details please refer to AutoShop software.

wState	Definition
0	Initialization
1	Disabled
2	Single Stop
3	Single Homing
4	Single Motion
5	Error Stop
6	Standstill
7	Stopping
8	Synchronous Motion

GroupAxes_0	_SMCGROUP_INFO		
wRingPos	INT	Dec	Configuration Number (Read Only, Monitoring)
wGroupID	INT	Dec	Axis Group Number (Read Only, Monitoring)
wState	INT	Dec	Status (read-only, monitoring)
wErrorCode	INT	Dec	Failure Code (Read-Only, Monitoring)
bMotionState	BOOL	Bin	Exercise Status (Read Only, Monitoring)
bHaltValid	BOOL	Bin	Pause state (read-only, monitoring)
wBufNum	INT	Dec	Number of buffers (read-only, monitoring)
sAxis_x	_sGROUFAXIS_INFO		X-axis status (read-only, monitoring)
wAxisID	INT	Dec	Axis number (read-only, monitoring)
wState	INT	Dec	Status (read-only, monitoring)
wErrorCode	INT	Dec	Failure Code (Read-Only, Monitoring)
fsetpos	REAL	Dec	Set location (read-only, monitoring)
factpos	REAL	Dec	Feedback location (read-only, monitoring)
fsetvel	REAL	Dec	Set Speed (Read Only, Monitor)
factvel	REAL	Dec	Feedback speed (read-only, monitoring)
sAxis_y	_sGROUFAXIS_INFO		Y-axis status (read-only, monitoring)
sAxis_z	_sGROUFAXIS_INFO		z-axis status (read-only, monitoring)
sAxis_a	_sGROUFAXIS_INFO		Auxiliary Axis Status (Read Only, Monitoring)
fSetvel	REAL	Dec	Set Speed (Read Only, Monitor)
fSetacc_dec	REAL	Dec	Set the plus (minus) speed (read-only, monitoring)
fSetvel_buf	REAL	Dec	Buffer Curve Set Speed (Read Only, Monitor)
fSetacc_d...	REAL	Dec	Buffer curve setting plus (minus) speed (read-only...
fSetdis	REAL	Dec	Set Distance (Read Only, Monitor)
fLeftdis	REAL	Dec	Remaining distance (read-only, monitoring)
fCenter_x	REAL	Dec	Coordinates of the x-point at the center of the ci...
fCenter_y	REAL	Dec	Coordinates of the Y-axis of the center of the cir...
fCenter_z	REAL	Dec	Coordinates of the z-axis of the center of the cir...
fRadius	REAL	Dec	Radius of circle for arc interpolation (read-only, ...
fStartAng	REAL	Dec	Arc interpolation start angle (read-only, monitoring)
fSetAng	REAL	Dec	Circular Interpolation Moving Angle (Read Only, Mo...

➤ MC_MoveLinear

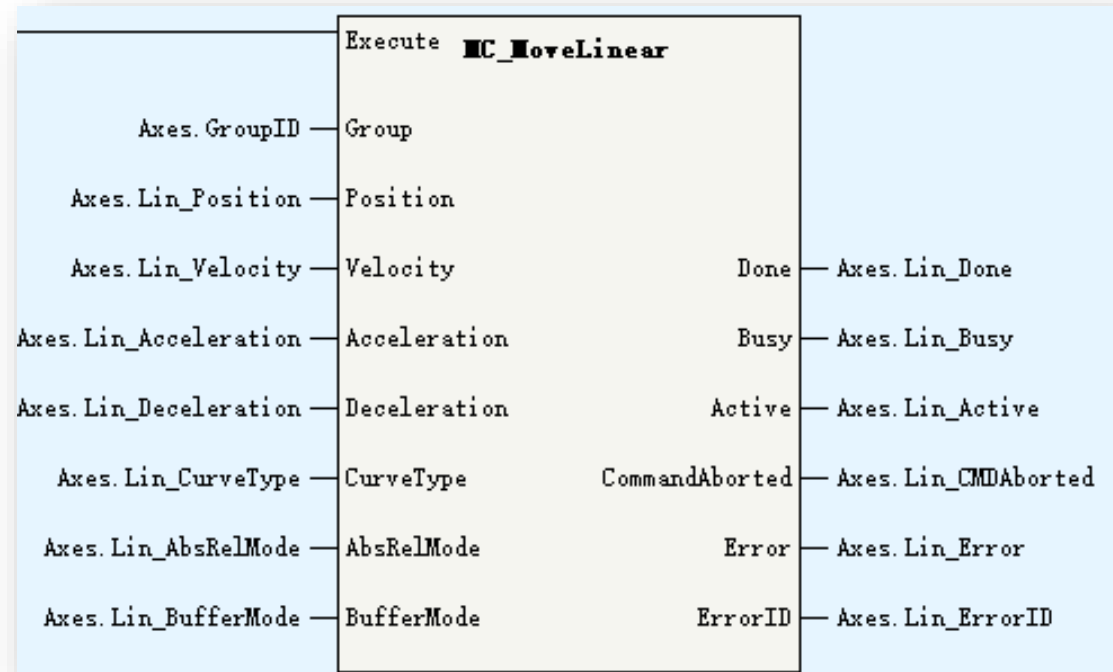

Parameters	Description
Group	Axes group ID
Position	Target position
Velocity	Target velocity
Acceleration	Acceleration
Deceleration	Deceleration
CurveType	Velocity Curve: 0: T type curve
AbsRelMode	0: absolute mode 1: relative mode
BufferMode	0: abort + no transition 1: buffer + no transition 2: former velocity + no transition 3: additional angle transition
Active	Executing current interpolation curve

MC_MoveLinear is used to move axes group linearly. While <Execute> triggered, input parameters will update and the FB will start to run.

Take note:

Only when all axis in group is standstill status, this command can execute, or there will be an error occur.

After this command executing, all axis in group will in synchronous motion state and cannot be aborted by single motion command.

After interpolation done, all axis in group will back to standstill state, at this time single motion command can be executed.

Don't support restart, if re-execute this command while <Busy> is ON, an error 9421 will occur.

➤ MC_MoveLinear-Position/Velocity

<Position> is an array data type, <Position[0]> set the X axis target position, <Position[1]> set Y axis target position, and so on for other axes.

$$V_x = V \cdot \cos\alpha \quad V_y = V \cdot \cos\beta \quad V_z = V \cdot \cos\gamma \quad V = \sqrt{v_x^2 + v_y^2 + v_z^2}$$

The auxiliary axis velocity is:

While X/Y/Z don't move, A axis will move follow the parameter <Velocity>

While X/Y/Z move, A axis will get into target position with X/Y/Z at the same time. For example, if displacement of X is L1, displacement of A is L2, then $V_a = V_x \cdot L2/L1$

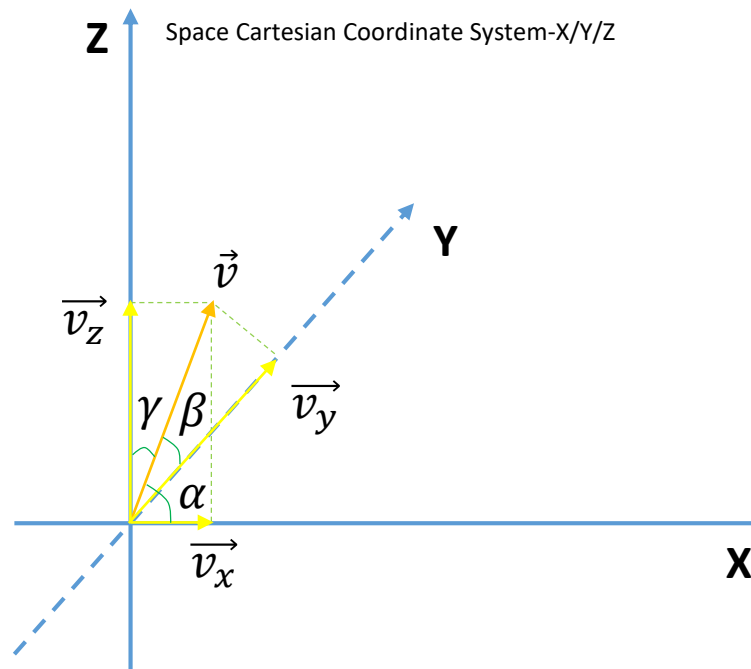

Motion Control(EtherCAT & Pulse Output)

➤ MC_MoveLinear-Mode

<AbsRelMode>=0, absolute mode, X/Y/Z/A move to <Position[0]>/<Position[1]>/<Position[2]>/<Position[3]>

<AbsRelMode>=1, relative mode, X/Y/Z/A move to Px + <Position[0]>/ Py + <Position[1]>/ Pz + <Position[2]>/ Pa + <Position[3]>, (Px, Py, Pz) is current coordinate system position, Pa is auxiliary axis position.

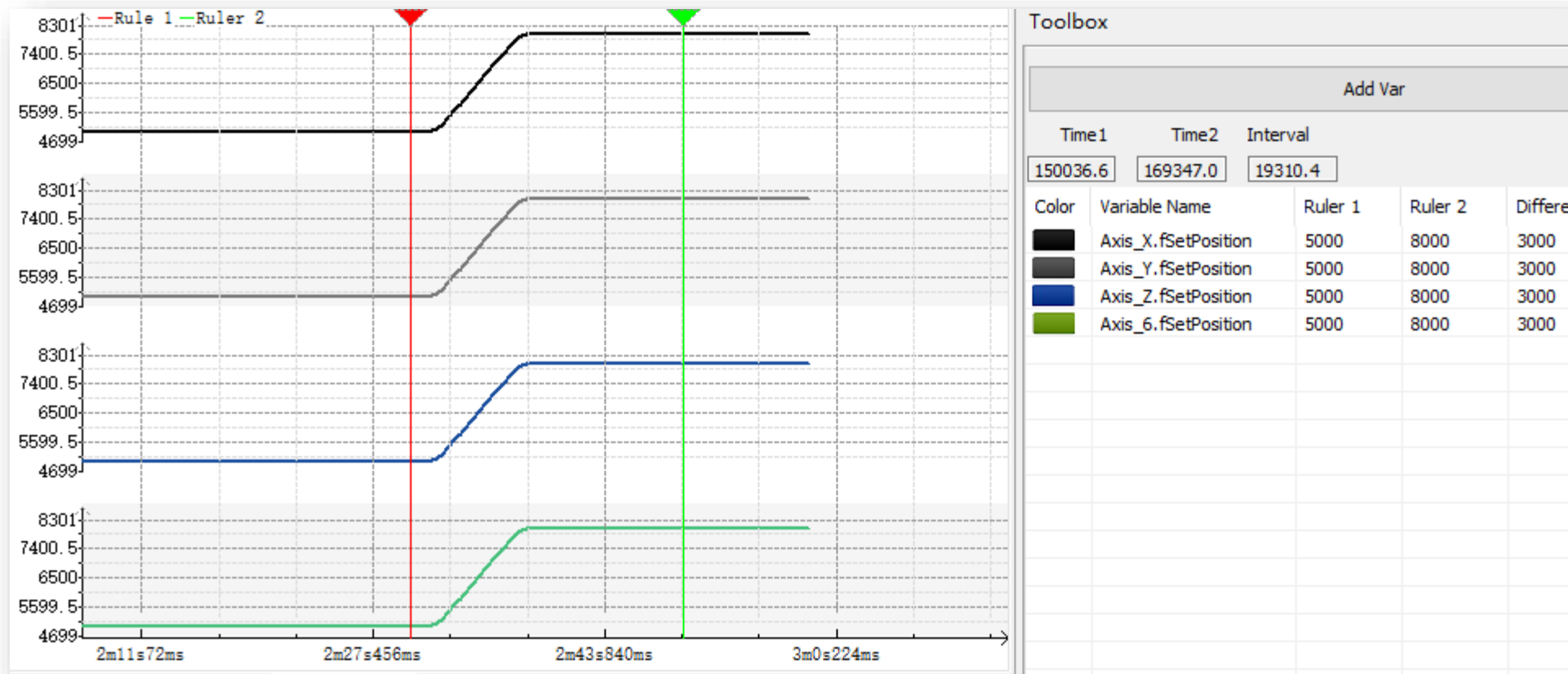

Start position is X/Y/Z(5000, 5000, 5000) + A(5000), target position is X/Y/Z(8000,8000,8000)+A(8000), absolute mode

Motion Control(EtherCAT & Pulse Output)

➤ MC_MoveLinear-Mode

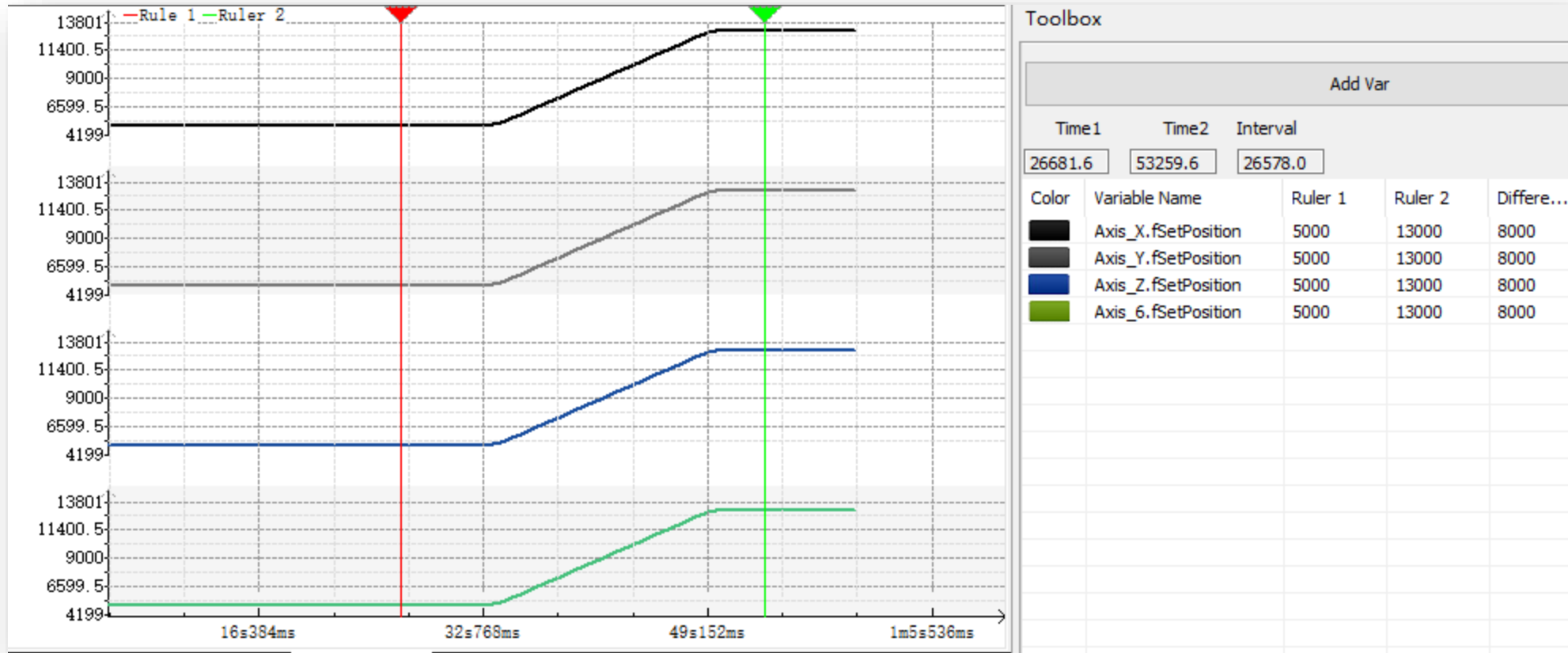

Start position is X/Y/Z(5000, 5000, 5000) + A(5000), target position is X/Y/Z(8000,8000,8000)+A(8000), relative mode

Motion Control(EtherCAT & Pulse Output)

➤ MC_MoveCircular

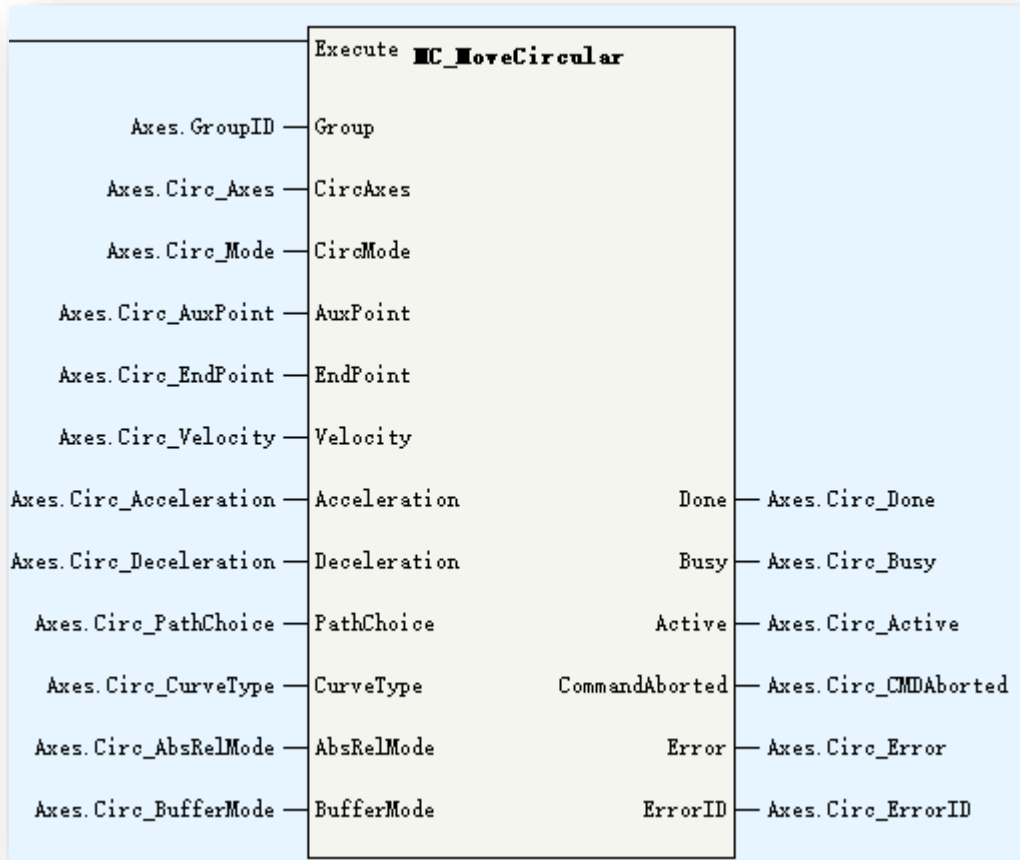

Parameters	Description
Group	Axes group ID
CircAxes	Circular motion base on: 0: x-y plane 1:y-z plane 2:x-z plane
CircMode	Circular interpolation mode: 0: 3 pass points 1: center point + start point + end point 2: radius + start point + end point
AuxPoint	Auxiliary points(array[0..3] of real)
EndPoint	End points(array[0..3] of real)
Velocity	Target velocity
Acceleration	Acceleration
Deceleration	Deceleration
PathChoice	0: CW 1: CCW
CurveType	Velocity curve 0: T type curve
AbRelMode	0: absolute mode 1: relative mode
BufferMode	0: abort + no transition 1: buffer + no transition 2: former velocity + no transition 3: additional angle transition
Active	Executing current interpolation curve

➤ MC_MoveCircular

MC_MoveCircular is used to move axes group circularly. While <Execute> triggered, input parameters will update and the FB will start to run.

Take note:

Only when all axis in group is standstill status, this command can execute, or there will be an error occur.

After this command executing, all axis in group will in synchronous motion state and cannot be aborted by single motion command.

After interpolation done, all axis in group will back to standstill state, at this time single motion command can be executed. Don't support restart, if re-execute this command while <Busy> is ON, an error 9421 will occur.

<CircAxes> specified coordinate plane. For example, while <CircAxes>=0, select X-Y coordinate plane. X axis and Y axis do circular interpolation motion, Z axis and A axis as auxiliary axes, do linear motion.

➤ MC_MoveCircular-Circle Mode

<CircMode>=0: 3 pass points mode. The circular(or arc) will generate according the given 3 points: start point, pass(middle) point and end point.

Start point is current position of axes group, the middle point is specified by <AuxPoint>, the end point is specified by <EndPoint>:
While select X-Y plane: start point is (Px, Py), middle point is (<AuxPoint[0]>, <AuxPoint[1]>), end point is (<EndPoint(0)>, <EndPoint(1)>)

While select Y-Z plane, start point is (Py, Pz), middle point is (<AuxPoint[1]>, <AuxPoint[2]>), end point is (<EndPoint(1)>, <EndPoint(2)>)

While select X-Z plane, start point is (Px, Pz), middle point is (<AuxPoint[0]>, <AuxPoint[2]>), end point is (<EndPoint(0)>, <EndPoint(2)>)

While start point is same as end point, the curve is a circle with a diameter as <start point ↔ middle point> distance. In this case, <PathChoice> will specified the motion direction of the circle, 0 is clockwise direction, 1 is counterclockwise direction.

Take note: except start point is same as end point, while 3 points in a line, the 3 points cannot form a circle.

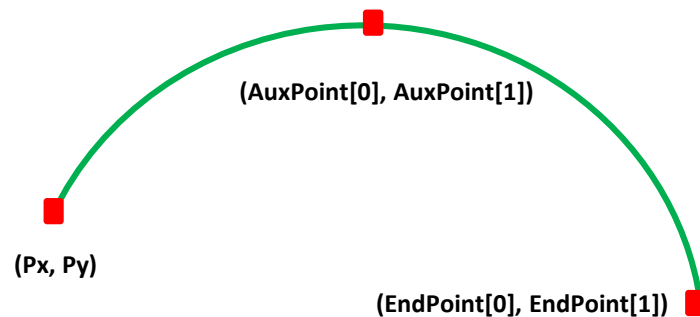

*Select X-Y plane, and start point <> end point

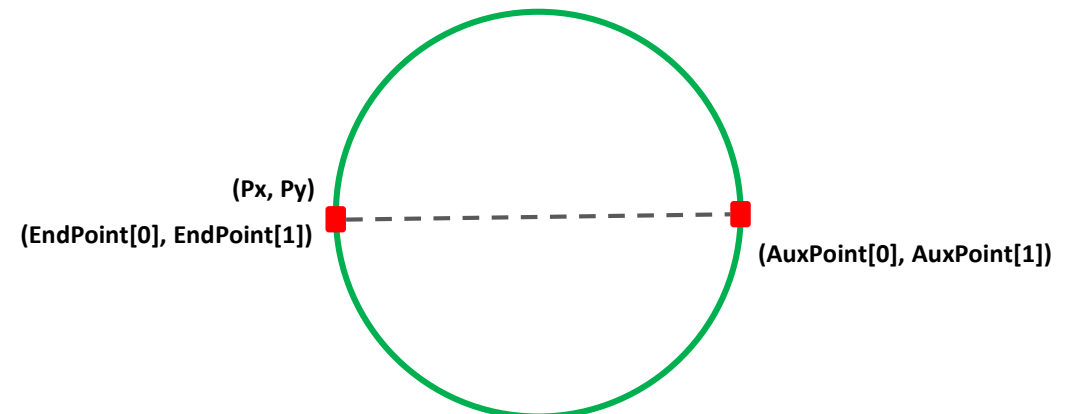

*Select X-Y plane, and start point = end point

➤ MC_MoveCircular-Circle Mode

<CircMode>=1: center point + start point + end point. The circular(or arc) will generate according the given 3 points: circle center, start point and end point.

Start point is current position of axes group, the center point is specified by <AuxPoint>, the end point is specified by <EndPoint>:
While select X-Y plane: start point is (Px, Py), center point is (<AuxPoint[0]>, <AuxPoint[1]>), end point is (<EndPoint(0)>, <EndPoint(1)>)

While select Y-Z plane, start point is (Py, Pz), center point is (<AuxPoint[1]>, <AuxPoint[2]>), end point is (<EndPoint(1)>, <EndPoint(2)>)

While select X-Z plane, start point is (Px, Pz), center point is (<AuxPoint[0]>, <AuxPoint[2]>), end point is (<EndPoint(0)>, <EndPoint(2)>)

Take note: While the distance between center and star point(R1) and distance between center and end point(R2) is different, interpolator will calculate the mean value $R(R=(R1+R2)/2)$, then calculate the new center point according to R. There could 2 center points calculated, at this time, the center point(C1) which is close to preset center point(C) will be selected, and, the new center point have to be in the circle of preset center(C) as circle center and $Rx<AuxPoint[3]>$ as radius.

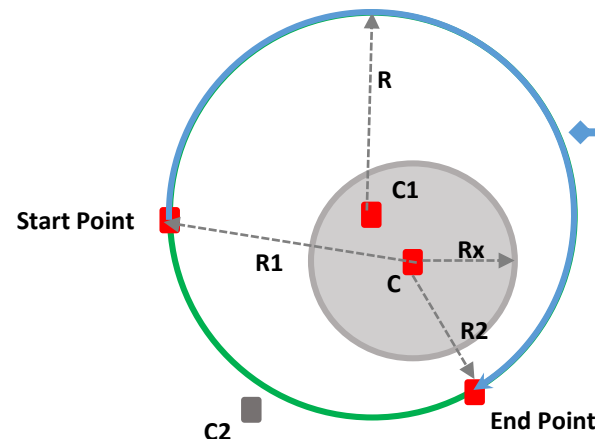

<Path Choice> to decide the interpolation direction, 0 is clockwise direction, 1 is counterclockwise direction

➤ MC_MoveCircular-Circle Mode

<CircMode>=2: radius + start point + end point. The circular(or arc) will generate according the given 3 parameters: radius, start point and end point.

Start point is current position of axes group, the radius is specified by <AuxPoint[0]>, the end point is specified by <EndPoint>:

While select X-Y plane, start point is (Px, Py), end point is (<EndPoint(0)>, <EndPoint(1)>)

While select Y-Z plane, start point is (Py, Pz), end point is (<EndPoint(1)>, <EndPoint(2)>)

While select X-Z plane, start point is (Px, Pz), <AuxPoint[2]>, end point is (<EndPoint(0)>, <EndPoint(2)>)

Take note: if radius value is negative, will generate the longer arc, if radius value is positive, will generate the shorter arc. The interpolation direction is set by <PathChoice>, 0 is clockwise direction, 1 is counterclockwise direction.

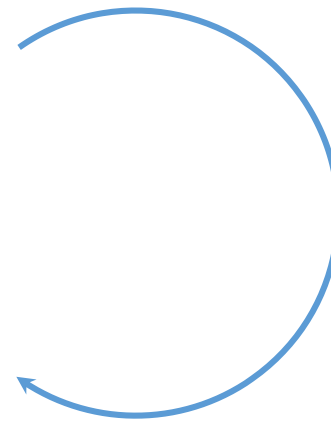
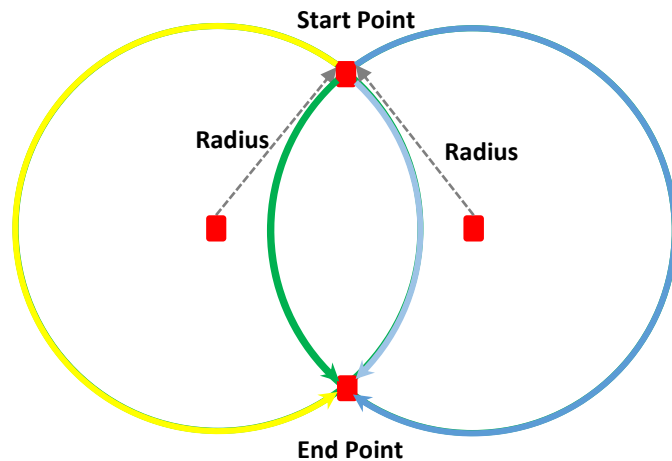

*<PathChoice>=0;
Radius value is negative



*<PathChoice>=0;
Radius value is positive

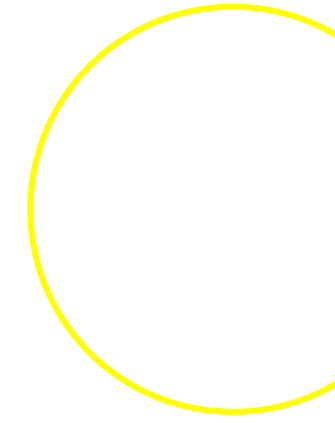

*<PathChoice>=1;
Radius value is negative



*<PathChoice>=1;
Radius value is Positive

➤ MC_MoveCircular-AbsRelMode

<AbsRelMode>=0, absolute mode, <AuxPoint> and <EndPoint> specified absolute position of axis.

<AbsRelMode>=1, relative mode, <AuxPoint> and <EndPoint> specified relative position of axis.

➤ MC_GroupStop

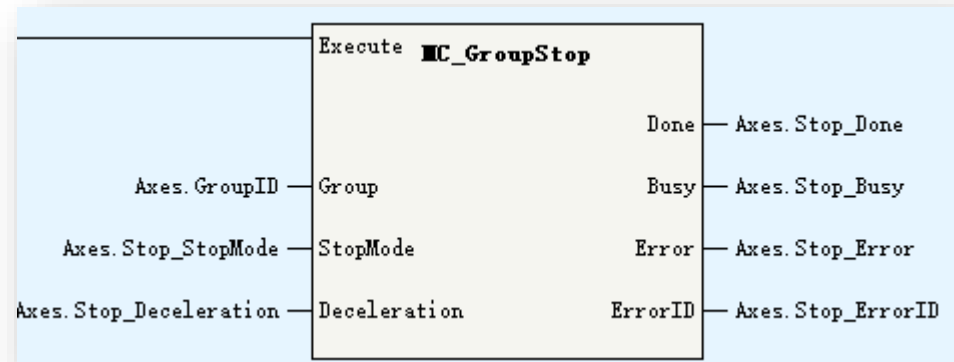

Parameters	Description
Group	Axes Group ID
StopMode	0: decelerate to stop 1: stop immediately
Deceleration	Deceleration

MC_GroupPause is used to stop the axes group motion.

After executing this command, axes group will decelerate to stop or stop immediately. When the axes group stopped and <Execute> enabled, the <Done> signal will valid and the axes group will keep in sync motion status. When the <Execute> signal disabled, the axes group will get into standstill status, at this time, can re-execute new interpolation motion or single axis motion.

Take note:

MC_GroupStop only works for interpolation commands(MC_MoveLinear, MC_MoveCircular).

Support restart, the deceleration follow the latest command.

Don't support multi commands, if over 1 MC_GroupStop commands execute at the same time, the error 9441 will occur.

Motion Control(EtherCAT & Pulse Output)

➤ MC_GroupStop

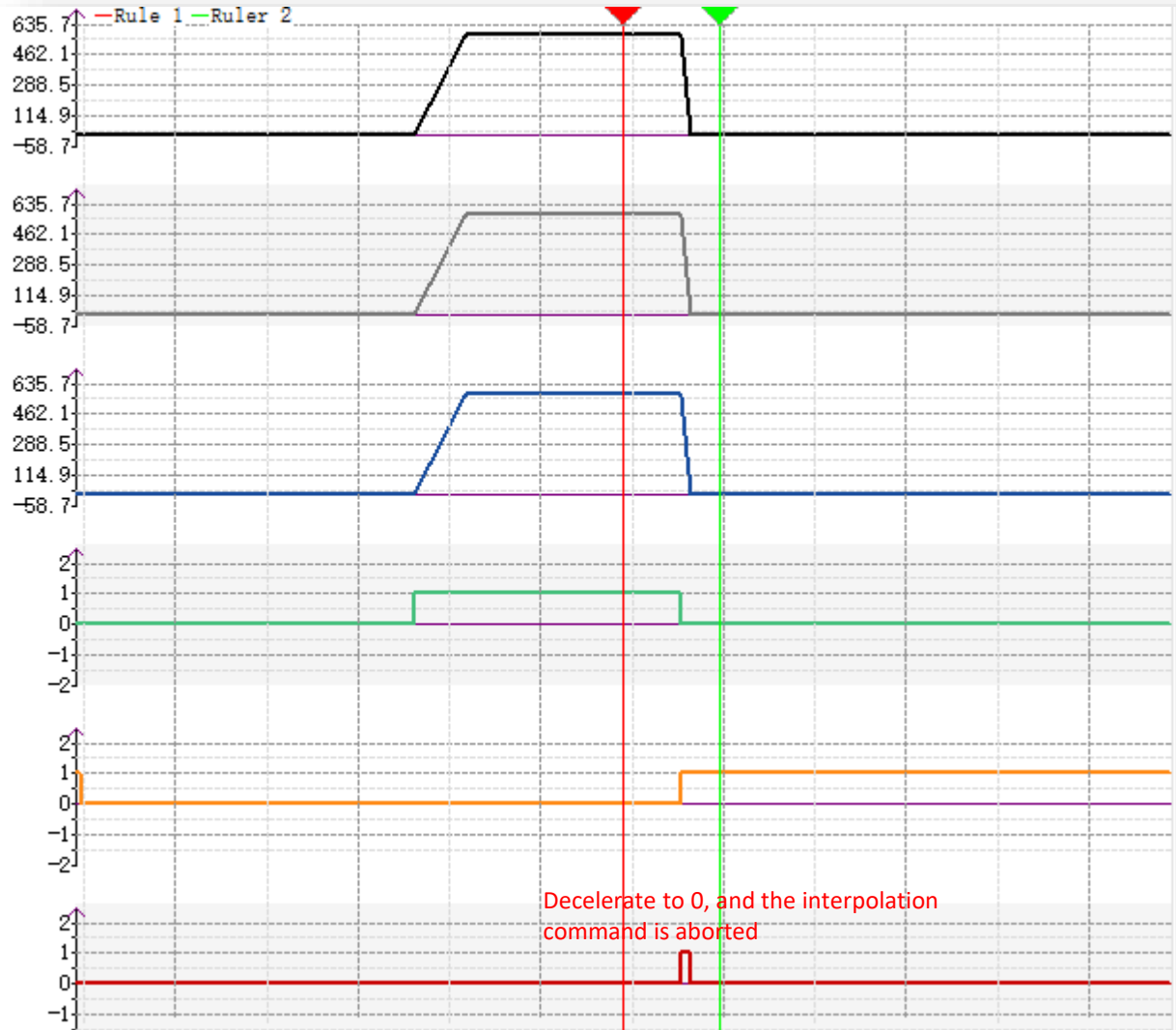

Toolbox

Add Var

	Time1	Time2	Interval
	26400.4	28572.4	2172.0

Color	Variable Name	Ruler 1	Ruler 2	Differe...
Black	Axis_X.fSetVelocity	577.350...	0	577.35...
Grey	Axis_Y.fSetVelocity	577.350...	0	577.35...
Blue	Axis_Z.fSetVelocity	577.350...	0	577.35...
Green	Axes.Lin_Active	1	0	1
Orange	Axes.Lin_CMDAborted	0	1	1
Red	Axes.Stop_Busy	0	0	0

➤ MC_GroupPause

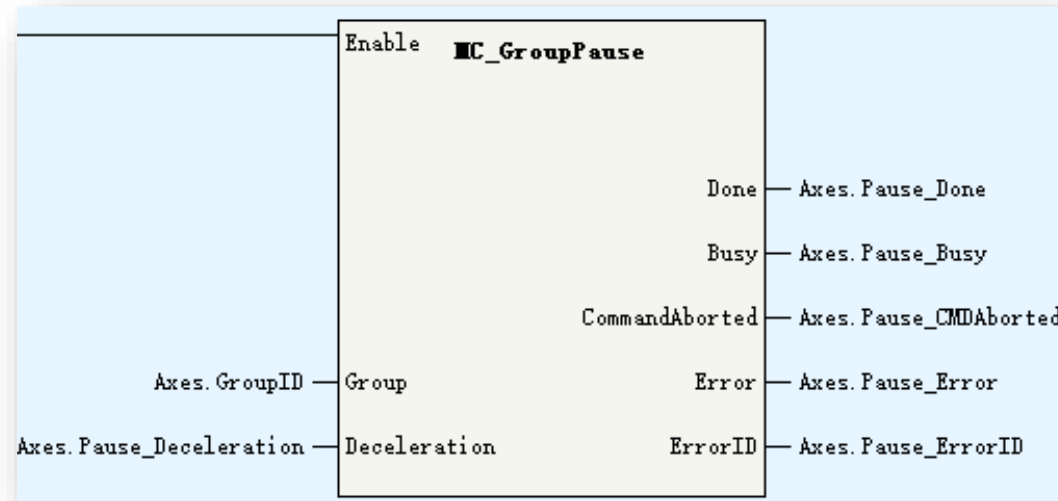

Parameters	Description
Group	Axes Group ID
Deceleration	Deceleration

MC_GroupPause is used to stop the axes group motion. Different from MC_GroupStop, this command will not change the motion state machine and will not stop the interpolation.

If the axes group in standstill status, after executing MC_GroupPause, axes group still in standstill, at this time if an interpolation FB execute, the interpolation will not execute immediately, but while disabled the MC_GroupPause FB, the interpolation motion will start.

If the axes group in sync motion status, after executing MC_GroupPause, axes group will decelerate to 0 speed and still be in sync motion status, while disabled the MC_GroupPause FB, the interpolation motion will continue.

Take note:

MC_GroupPause only works for interpolation commands(MC_MoveLinear, MC_MoveCircular).

Support restart and multi start, the deceleration follow the latest command.

Motion Control(EtherCAT & Pulse Output)

➤ MC_GroupPause

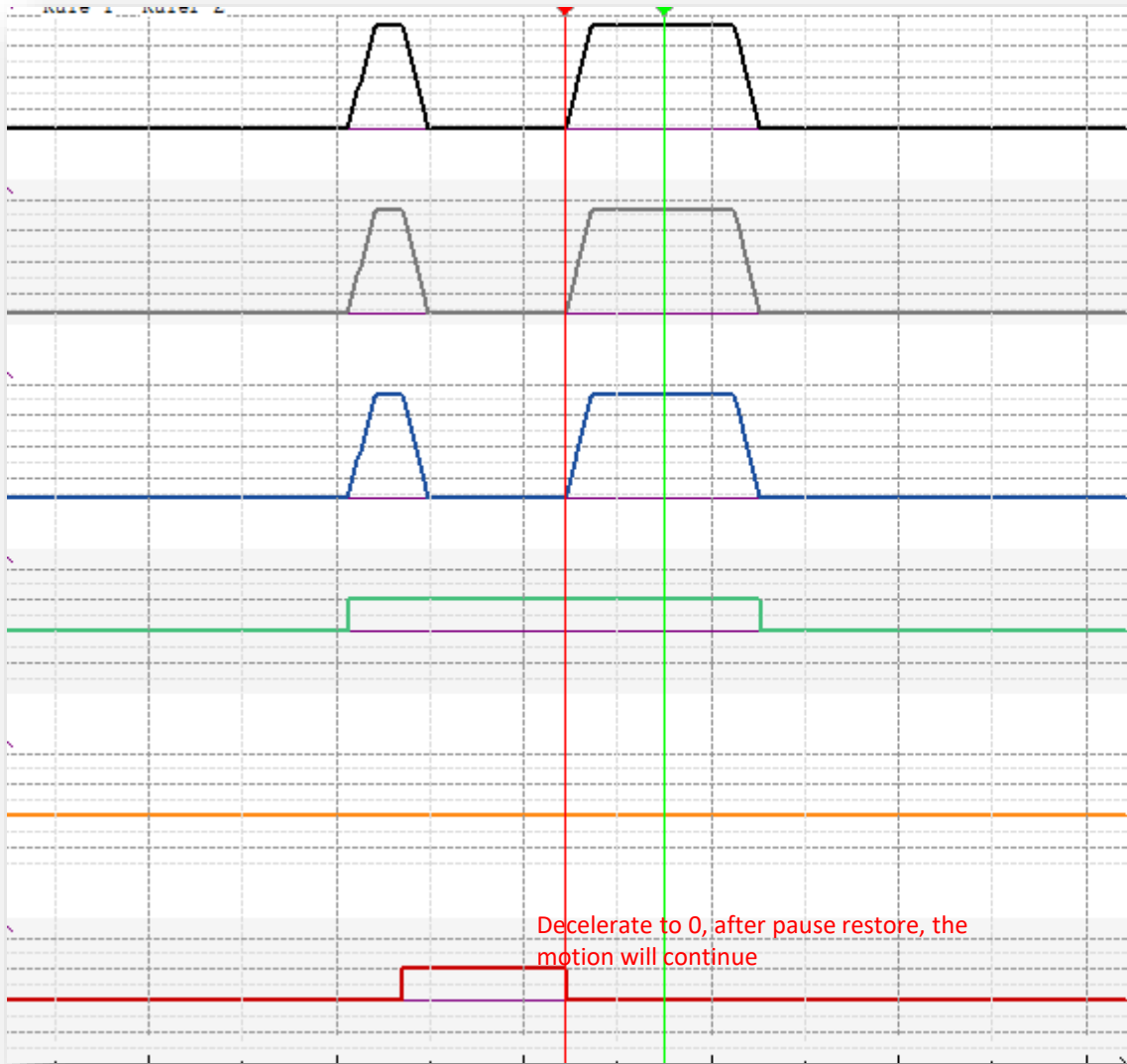

IOIDBOX

Add Var

Time1	Time2	Interval
29410.2	32361.3	2951.1

Color	Variable Name	Ruler 1	Ruler 2	Differe...
Black	Axis_X.fSetVelocity	0	0	0
Grey	Axis_Y.fSetVelocity	0	0	0
Blue	Axis_Z.fSetVelocity	0	0	0
Green	Axes.Lin_Active	0	0	0
Orange	Axes.Lin_CMDAborted	0	0	0
Red	Axes.Pause_Busy	0	0	0

➤ BufferMode

MC_MoveLinear/MC_MoveCircular support 4 buffer modes.

0: abort + no transition: change to another interpolation curve immediately, no transition

1: buffer + no transition: after current interpolation complete and decelerate to 0, execute the next interpolation curve, no transition

2: former velocity + no transition: interpolator will try to complete current interpolation with current velocity, and start the second interpolation with current velocity, no transition

3: additional angle transition, with transition curve: when current interpolation deceleration and next interpolation acceleration executing at the same time.

Motion Control(EtherCAT & Pulse Output)

➤ BufferMode

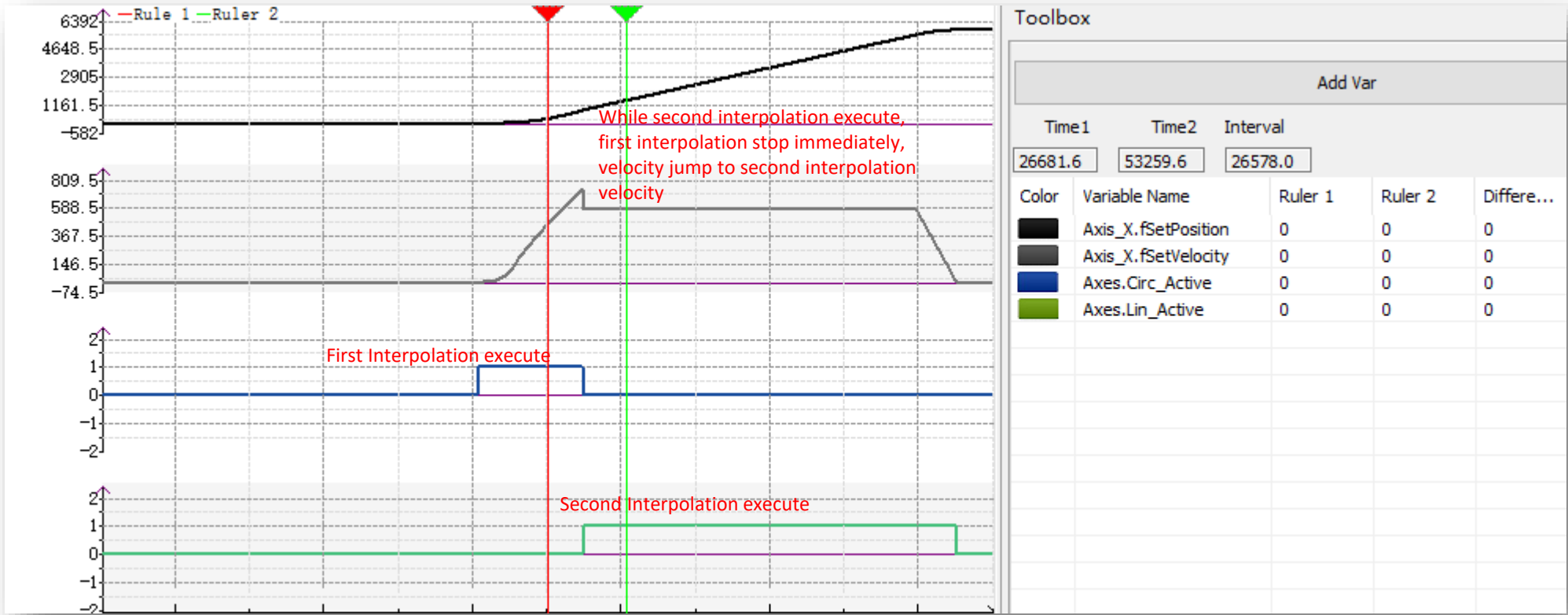

Buffer Mode = 0, abort + no transition

Motion Control(EtherCAT & Pulse Output)

➤ BufferMode

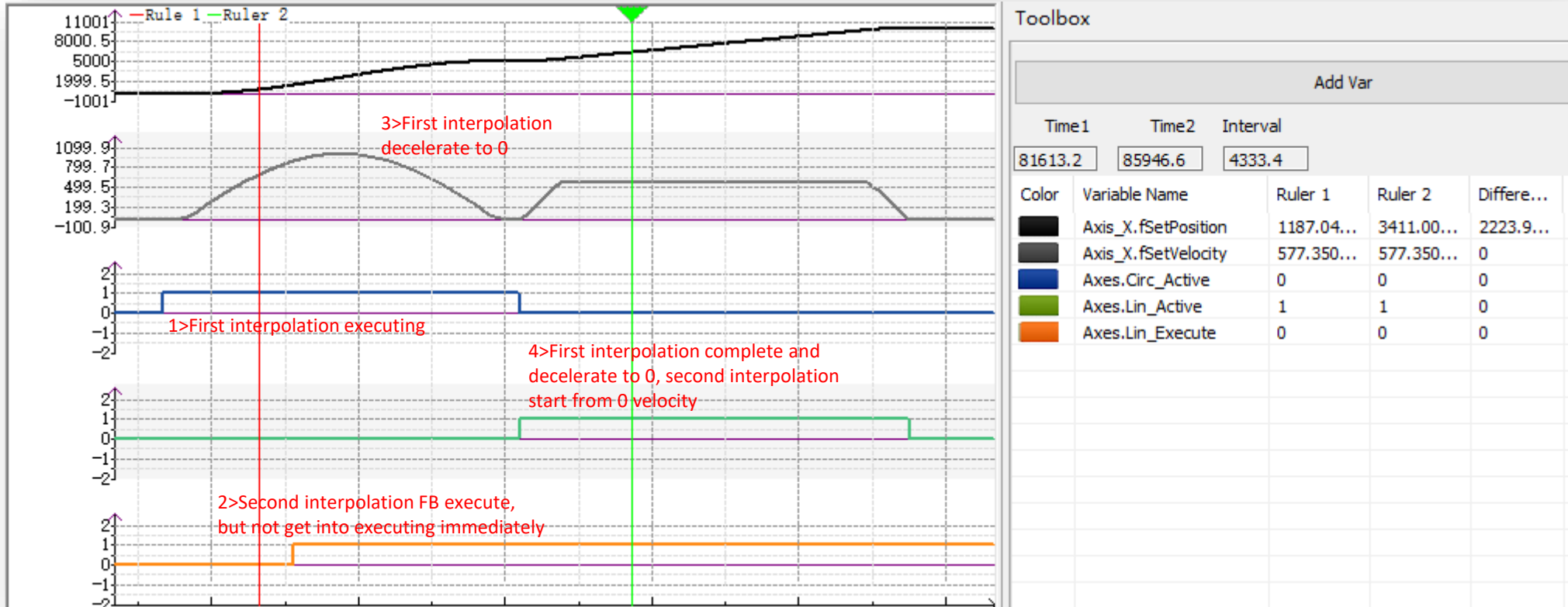

Buffer Mode = 1, buffer + no transition

Motion Control(EtherCAT & Pulse Output)

➤ BufferMode

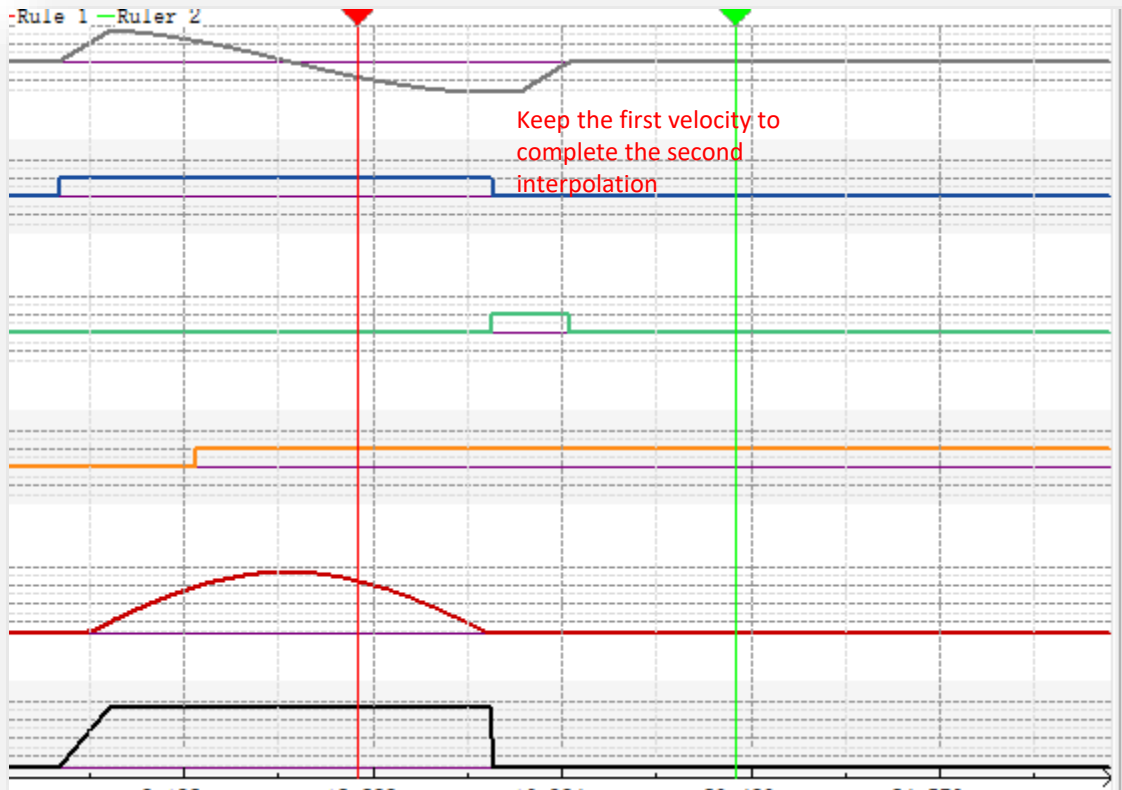

Toolbox

Add Var

Time1	Time2	Interval
11937.8	20127.0	8189.2

Color	Variable Name	Ruler 1	Ruler 2	Differe...
Black	Axis_Y.fSetVelocity	-506.22...	0	506.22...
Blue	Axes.Circ_Active	1	0	1
Green	Axes.Lin_Active	0	0	0
Orange	Axes.Lin_Execute	1	1	0
Red	Axis_X.fSetVelocity	862.400...	0	862.40...
Black	Axis_Z.fSetVelocity	127.323...	0	127.32...

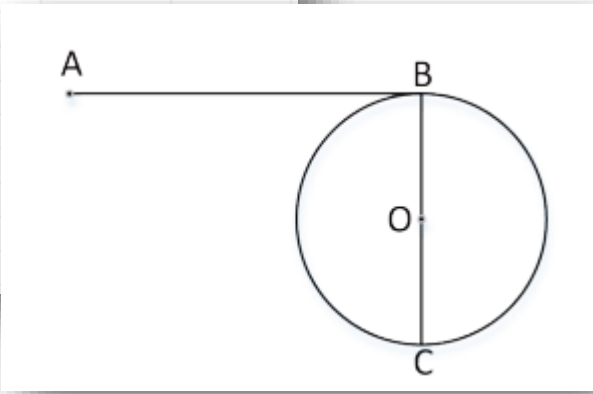

Buffer Mode =2, former velocity + no transition

Take note :

Buffer mode=2 will try to keep first interpolation velocity to execute second interpolation. But it not means the velocity is static. For example, if the first interpolation is circular motion, some axis end velocity is 0, and while execute the second interpolation, there could be a velocity jump. To make the velocity constant(or continuous), need consider the real motion situation.

Motion Control(EtherCAT & Pulse Output)

➤ BufferMode

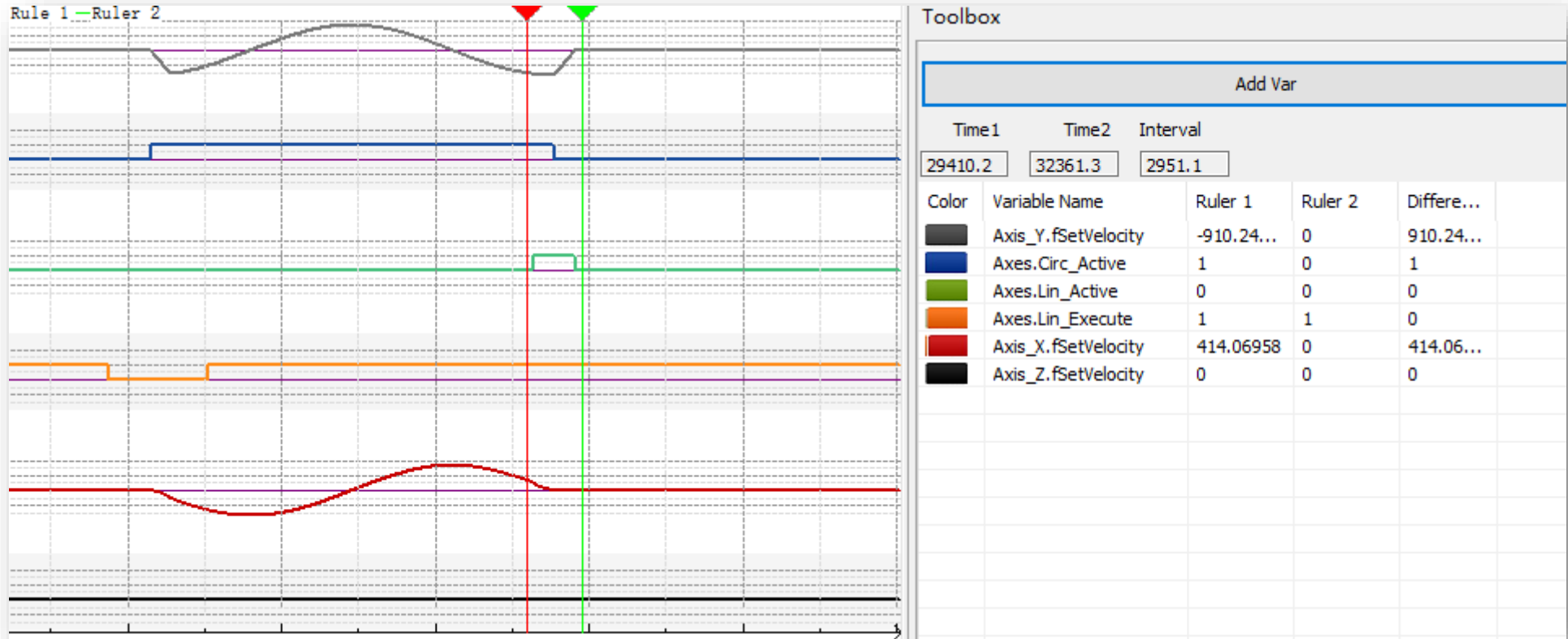

Buffer Mode =3, additional angle transition, with transition curve

Take note :

Buffer Mode =3. While interpolator detect that first interpolation start to decelerate, the second interpolation will start to execute. Each axis velocity equal to the summary of velocity components of first interpolation and second interpolation. The velocity curve will be continuous.

➤ AxesGroup Reset

If axes group in error status, users can check the status of axis in group with single axis command(MC_ReadStatus), using axes group data structure or monitoring function in axes group configuration view, also need check the error code of the error reported function block. After confirm (and solved) the error, users can using MC_Reset FB to reset corresponding axis.

Take note:

Only when all axis in group in standstill status, the axes group will get into standstill status.

➤ Single axis configuration in axes group

Single axis setting	In axes group
Gear ratio	Follow the single axis <unit conversion setting>
Encoder mode	Follow the single axis encoder mode(absolute or incremental)
Mode setting	Axes group only support linear mode, so need set the mode as linear mode in single axis configuration
Limit	Axis in group support the limit setting in single axis configuration
Following error threshold	Axis in group support the following error setting
Velocity limit	Axis in group limited by the velocity limit setting in single axis configuration, but the maximum acceleration will not follow single axis configuration
Torque limit	None

Motion Control(CANopen)

CANopen Motion Control	Function
MC_Power_CO	Axis enable control
MC_Reset_CO	Axis error reset
MC_ReadActualVelocity_CO	Read axis velocity
MC_ReadActualPosition_CO	Read axis position
MC_Halt_CO	Stop axis
MC_Stop_CO	Emergency stop axis
MC_MoveVelocity_CO	Axis move in velocity
MC_MoveRelative_CO	Axis move relatively
MC_MoveAbsolute_CO	Axis move absolutely
MC_Home_CO	Axis homing
MC_Jog_CO	Axis jog
MC_WriteParameter_CO	Write parameter
MC_ReadParameter_CO	Read parameter

CANopen motion commands is used to control inovance CANopen servo, which support up to 16 axes.

Motion Control(CANopen)

➤ CANopen Configuration

The screenshot shows the software interface for CANopen configuration. On the left is the Project Manager tree, and on the right is the CAN Config dialog box. Annotations with blue arrows and green boxes provide step-by-step instructions:

- 1-<Project Manager>→CAN double click**: Points to the 'CAN(CANopen)' item in the Project Manager tree.
- 2-Select <CANopen>**: Points to the 'CANopen' checkbox in the 'CAN Port Setting' section of the dialog box.
- 3-Communication Parameter using default: Station No. 63 Baud rate 500 kbps**: Points to the 'Station No.' field (set to 63) and the 'Baud Rate' dropdown (set to 500 Kbps) in the 'Communicate Param' section.
- 4-Click <OK>**: Points to the 'OK' button at the bottom of the dialog box.

Additional text in the dialog box includes: 'Please right click to add the main config.' and 'Station: 63 1 <= Station NO. <= 63'.

➤ CANopen Configuration

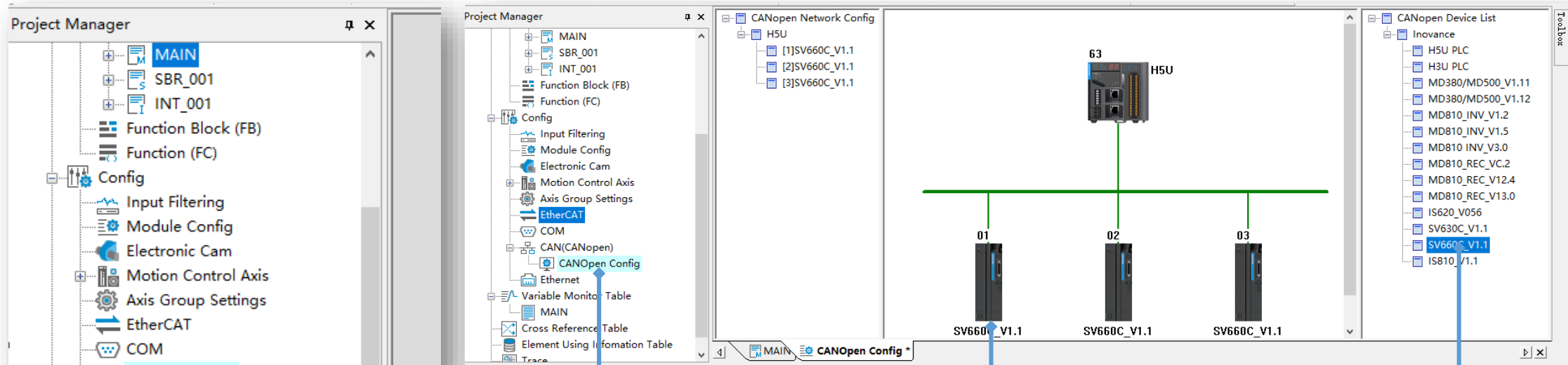

5-<Project Manager>→CAN Right click to add CAN configuration

6-Click <CANopen Config> to open the configuration view

8-Click the device to get into device configuration view(next slide)

7-Click from the device list to add the device

Motion Control(CANopen)

➤ CANopen Configuration

Node ID will automatically generated, the range is 1~63

Check the <Enable Expert setting> to enable CANopen communication setting, normally use the default set.

Error Control:
Node protection and heart beat cannot selected at the same time. Recommend to use node protection. The difference is node protection is sent-receive confirmation mechanism, the heart beat only sent heart beat frame periodically but slave no reply.

Error Control:
Enable sync production and emergency frame.

Restart parameters.

Motion Control(CANopen)

➤ CANopen Configuration

SV660C_V1.1

Slave Node			Set The Axis Parameters		Receive PDO		Send PDO
Service Data Objects			Debug	I/O Mapping		Module information	
Number	Index	Subindex	Name	Value	Bit Length	Download	
1	16#1000	16#00	Device type	0x00020192	32	*	
2	16#1018	16#01	Vendor ID	0x000003B9	32		
3	16#1018	16#02	Product code	0x000D010C	32		
4	16#1018	16#03	Revision number	0x00020001	32		
5	16#1400	16#01	Disable PDO	0x80000201	32	*	
6	16#1401	16#01	Disable PDO	0x80000301	32	*	
7	16#1402	16#01	Disable PDO	0x80000401	32	*	
8	16#1403	16#01	Disable PDO	0x80000501	32	*	
9	16#1600	16#00	Clear PDO mapping	0x00	8	*	
10	16#1601	16#00	Clear PDO mapping	0x00	8	*	
11	16#1602	16#00	Clear PDO mapping	0x00	8	*	
12	16#1603	16#00	Clear PDO mapping	0x00	8	*	
13	16#1800	16#01	Disable PDO	0xC0000181	32	*	
14	16#1801	16#01	Disable PDO	0xC0000281	32	*	
15	16#1802	16#01	Disable PDO	0xC0000381	32	*	
16	16#1803	16#01	Disable PDO	0xC0000481	32	*	
17	16#1A00	16#00	Clear PDO mapping	0x00	8	*	
18	16#1A01	16#00	Clear PDO mapping	0x00	8	*	
19	16#1A02	16#00	Clear PDO mapping	0x00	8	*	
20	16#1A03	16#00	Clear PDO mapping	0x00	8	*	
21	16#1400	16#02	Set transmission type	0x01	8	*	
22	16#1401	16#02	Set transmission type	0x01	8	*	
23	16#1600	16#01	1st receive PDO mapping	0x60400010	32	*	
24	16#1600	16#02	1st receive PDO mapping	0x60FF0020	32	*	
25	16#1600	16#03	1st receive PDO mapping	0x60600008	32	*	
26	16#1601	16#01	2nd receive PDO mapping	0x607A0020	32	*	
27	16#1601	16#02	2nd receive PDO mapping	0x60810020	32	*	

SDO Timeout: ms

SDO Edit

When select <Enable expert setting> in <Slave Node>, users can manually add SDO in this page. All SDO will update in CANopen field bus start process(pre-operational status).

Motion Control(CANopen)

➤ CANopen Configuration

SV660C_V1.1

Service Data Objects Debug I/O Mapping Module information

Slave Node Set The Axis Parameters Receive PDO Send PDO

Axis Parameter Settings Axis Zero Parameter Settings

set axis parameters

Axis No: 1

display unit

pulse mm micron degree inch

set axis scale

pulses of one circle on the motor(1): 16#100000 pulses/cirde

distance of one circle on the Working gear(3): 1 Millimeter/Ro

Set the gear ratio

Working gear ratio(5): 1

Working gear ratio(4): 1

pulses = $\frac{\text{pulses of one circle on the motor(1)} * \text{Working gear ratio(5)}}{\text{distance of one circle on the Working gear(3)} * \text{Working gear ratio(4)}} * \text{distance}$

<Set the axis parameters> used to set the gear ratio and conversion ratio between user unit and encoder unit.

Motion Control(CANopen)

➤ CANopen Configuration

Creation Time	Error Code ...	Error Register (16#)	Manufacturer Error ...

<Debug> is used to monitoring CANopen bus status and support SDO reading.

Take note:
H5U share same CANopen configuration with H3U, for more details of CANopen configuration, users can refer to H3U manual.

Motion Control(CANopen)

➤ Motion Control Function Block

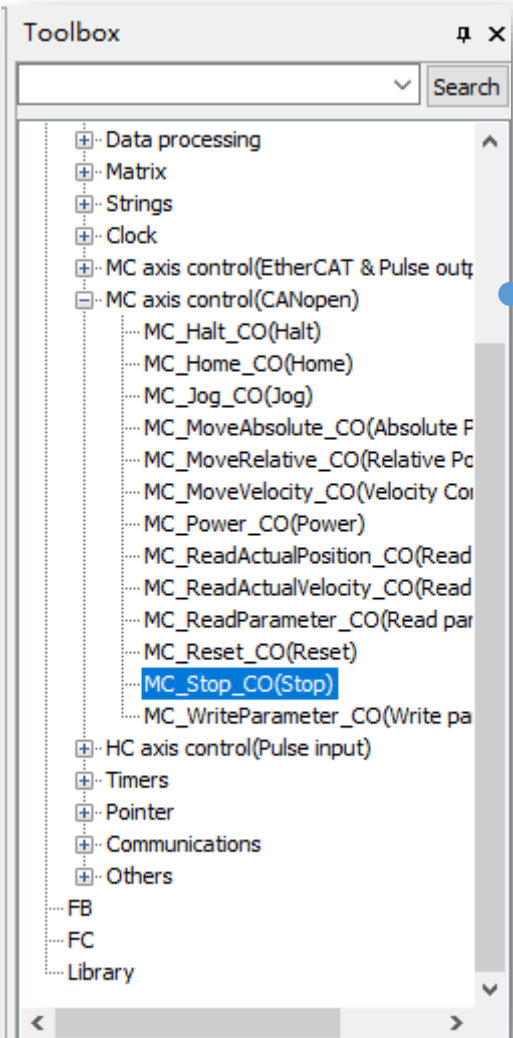

Select the CANopen motion FBs from toolbox to LD diagram.

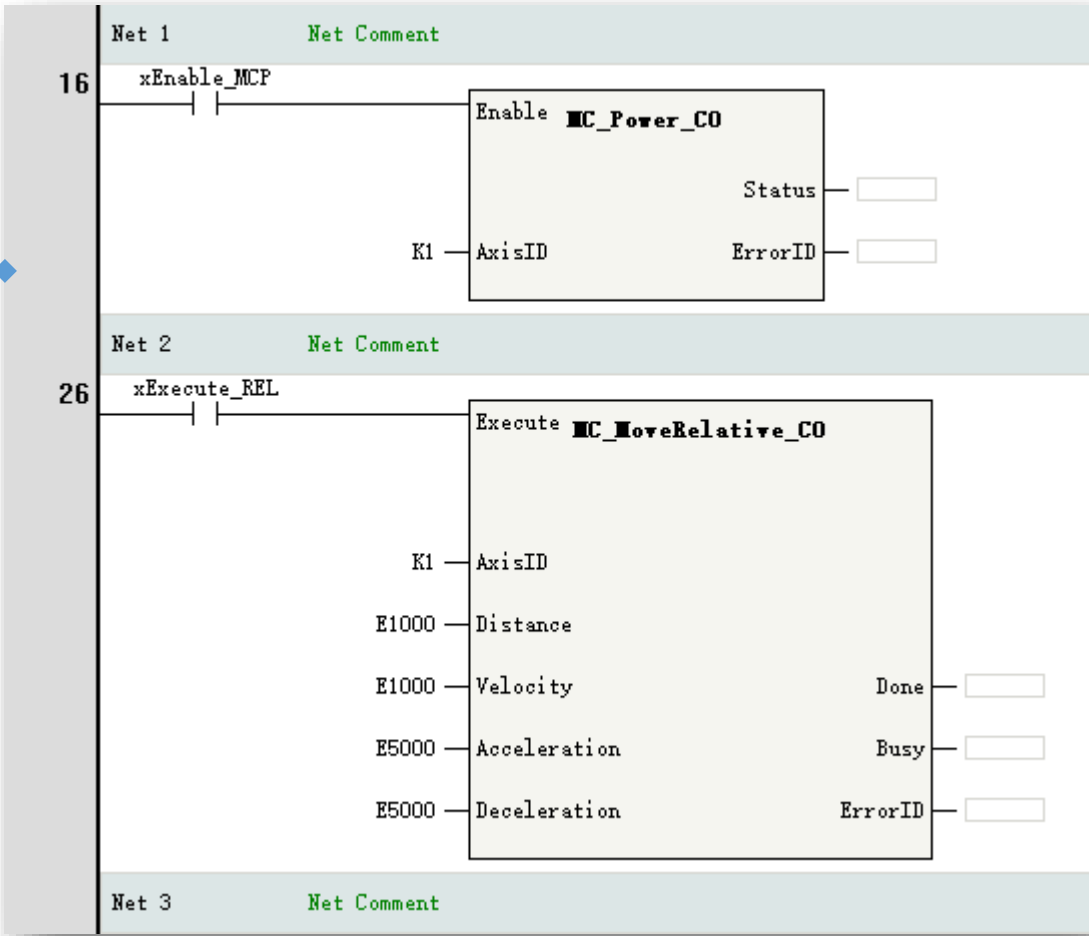

High Speed Input

Field bus encoder	Function
ENC_Counter	Encoder enable
ENC_Reset	Encoder reset
ENC_Preset	Encode value preset
ENC_TouchProbe	Encoder touch probe
ENC_ArrayCompare	Encoder array comparison
ENC_StepCompare	Encoder step(certain distance) comparison
ENC_GroupArrayCompare	Encoder array comparison(2 dimension array)
ENC_ReadStatus	Read encoder status
ENC_DigitalOutput	Encoder digital output control
ENC_ResetCompare	Encoder reset comparison output

HS counter	Function
HC_Counter	Enable high speed counter
HC_Preset	HS counter value preset
HC_TouchProbe	HS counter touch probe
HC_Compare	HS counter comparison
HC_ArrayCompare	HS counter array comparison
HC_SetCompare	HS counter step(certain distance) comparison

High Speed Input

➤ Add encoder axis

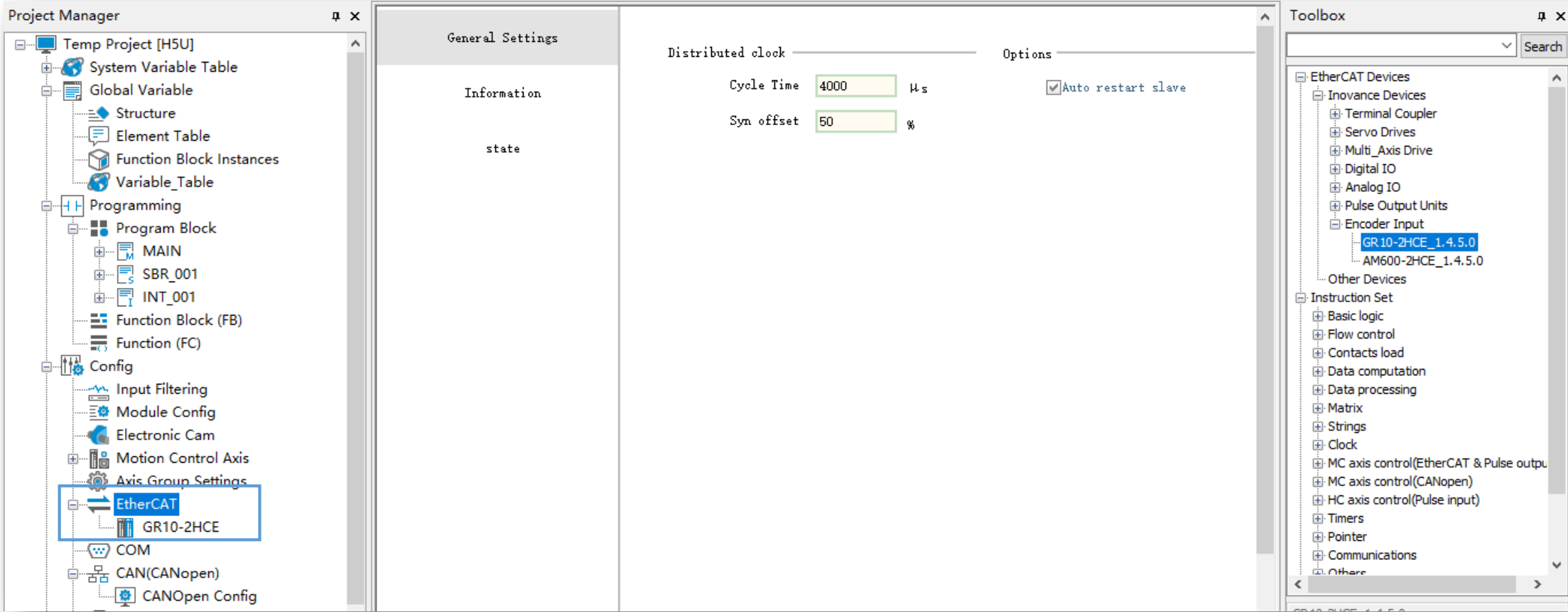

1> Open <Config>→<EtherCAT>, select GR10-2HCE model to add to EtherCAT device list.

High Speed Input

➤ Add encoder axis

Basic Settings	Basic Settings: Axis number: 0 Axis type: Bus Encoder Axis Input Device: GR10-2HCE:0 Output Device: Unassigned						
Unit Conversion Settings	<input type="checkbox"/> Virtual Axis M						
Mode/Parameter Settings	<table border="1"> <tr> <td>GR10-2HCE:0</td> <td></td> </tr> <tr> <td>GR10-2HCE:1</td> <td></td> </tr> <tr> <td>Function Name</td> <td>Process</td> </tr> </table>	GR10-2HCE:0		GR10-2HCE:1		Function Name	Process
GR10-2HCE:0							
GR10-2HCE:1							
Function Name	Process						

2> add a motion control axis, select <Bus Encoder Axis> and assign the <Input Device>, then the bus encoder axis can be used in program. For local encoder axis, select <Local Encoder Axis> assign the <Input Device>, H5U support up to 4 built in local counter. For more motion axis configuration, please refer to [Motion Control Axis Configuration](#)

Basic Settings	Basic Settings: Axis number: 1 Axis type: Local Encoder Axis Input Device: High speed counter 0 Output Device: Unassigned								
Unit Conversion Settings	<input type="checkbox"/> Virtual Axis M								
Mode/Parameter Settings	<table border="1"> <tr> <td>High speed counter 0</td> <td></td> </tr> <tr> <td>High speed counter 1</td> <td></td> </tr> <tr> <td>High speed counter 2</td> <td></td> </tr> <tr> <td>High speed counter 3</td> <td></td> </tr> </table>	High speed counter 0		High speed counter 1		High speed counter 2		High speed counter 3	
High speed counter 0									
High speed counter 1									
High speed counter 2									
High speed counter 3									

High Speed Input

➤ ENC_Counter

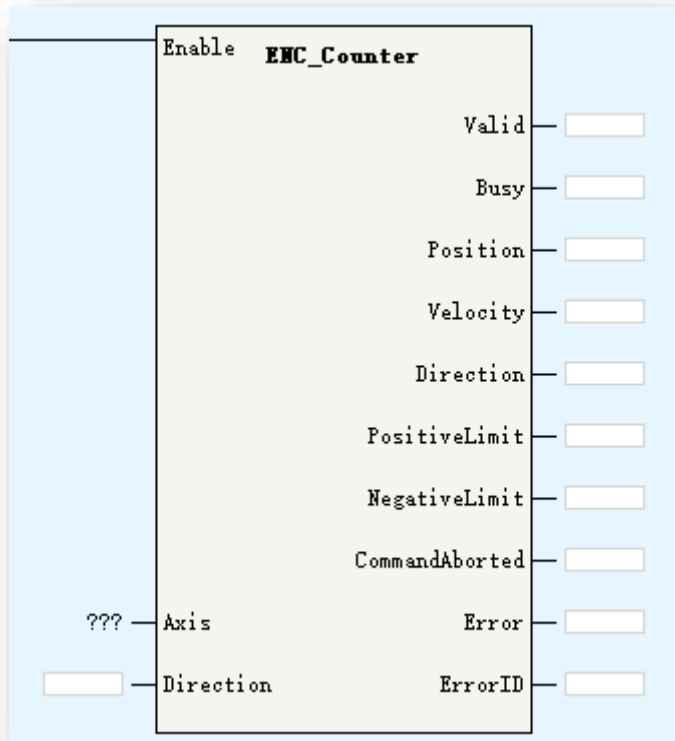

Parameters	Description
Axis	Encoder Axis name (bus encoder axis)
Direction	reserved
Valid	Encoder input valid
Position	Current position
Velocity	Current velocity
Direction	Current direction
PositiveLimit	Positive limit valid in linear mode
NegativeLimit	Negative limit valid in linear mode

ENC_Counter is used to enable the bus encoder axis.

When <Enable> is ON, <Busy> will be valid, when counter start to count, <Valid> will turn ON. The <Position>/<Velocity>/<Direction> will display current counter specifications.

While axis works in linear mode and counter up to positive or negative limit, <PositiveLimit> and <NegativeLimit> will be valid and counter stop counting.

➤ ENC_Counter

Basic Settings

Unit Conversion Settings

Mode/Parameter Settings

Mode Selection:

Mode Settings: Linear Mode Rotation Mode

Software Limits: Enable
Negative limit value: 0.00 Unit Forward Limit: 10

Count parameter settings:

Count Mode: A/B phase 4x
Count logic: Positive Logic Inverse Logic

Frequency sampling period: 10 ms Input filter time: 4 μs

X00 Settings:

Selection: Gated
General Input
Level Logic: Probe Function 1 Inverse Logic
Reset
Preset
Gated

Y00 Settings:

Selection: One dimensional comparison Output
Level Logic: Positive Logic Inverse Logic
Break Output status: Keep status Output set value
Set value: OFF ON

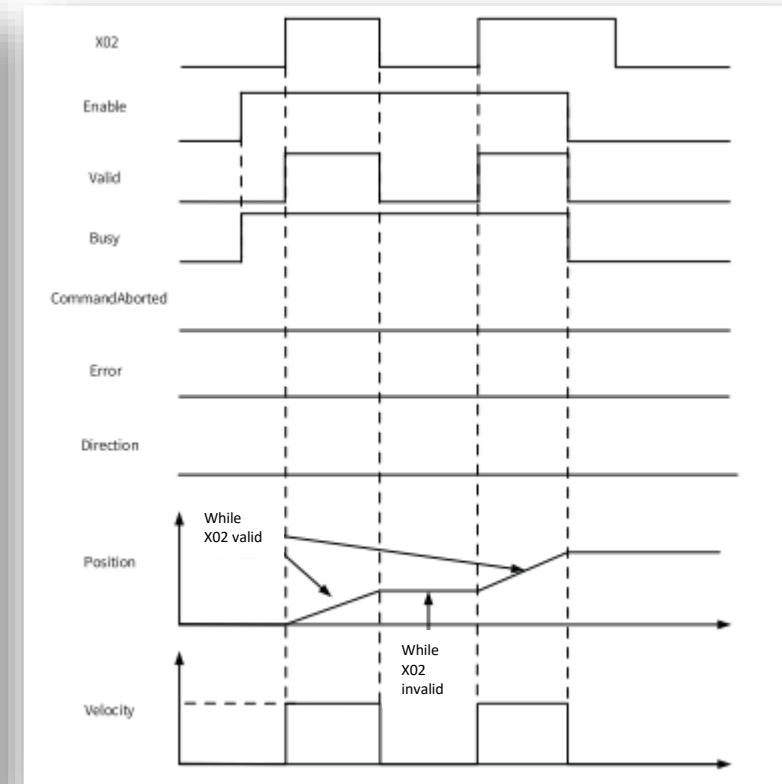

*X02(2HCE model) selected as <Gated> input for bus encoder counter

If select <Gated> in digital input setting, the corresponding input signal will control the encoder count, and the <Valid> will be ON when the gated signal valid(encoder counting), <Valid> will be OFF when the gated signal invalid(encoder not counting)

High Speed Input

➤ ENC_Reset

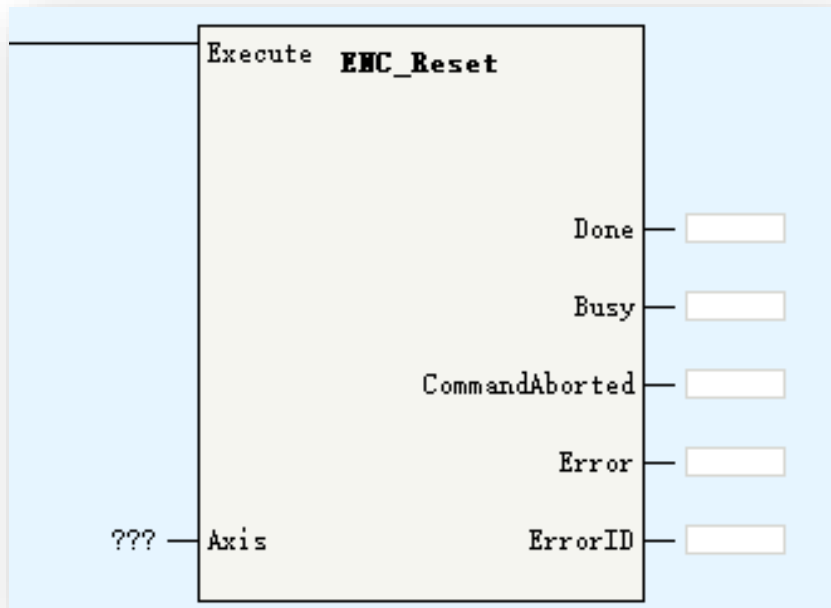

Parameters	Description
Axis	Encoder Axis name (bus encoder axis)

ENC_Reset is used to reset bus encoder axis when axis is in error.

High Speed Input

➤ ENC_Preset

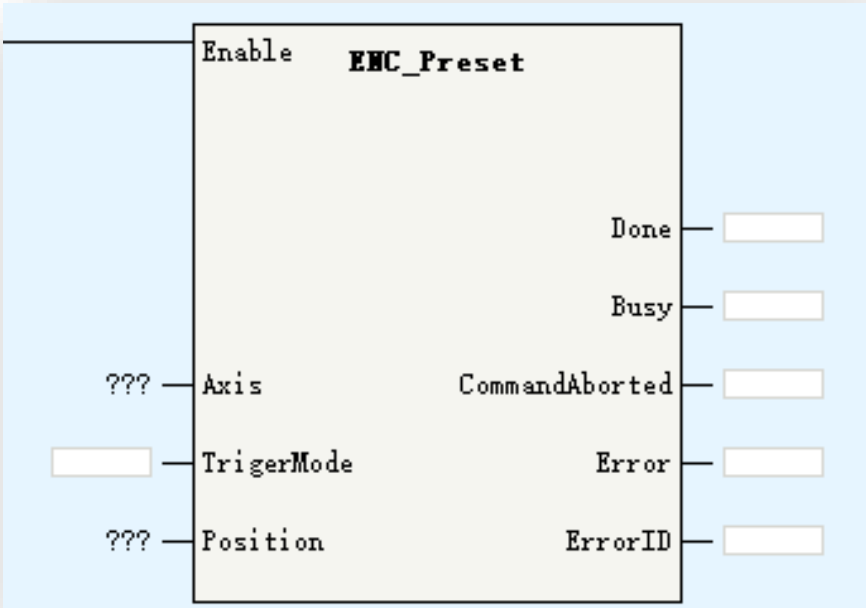

Parameters	Description
Axis	Encoder Axis name (bus encoder axis)
TriggerMode	0: trigger in command rising edge 1: digital input rising edge 4: Z signal
Position	Preset position

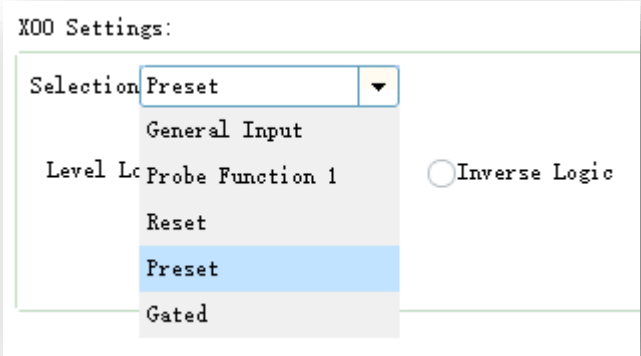

*Select DI as <Preset> functionality in axis configuration view.

ENC_Preset is used to set bus encoder current position as <Position>(input parameter).

- While <TriggerMode>=0, position set when FB enabled;
- While <TriggerMode>=1, position set when digital input(of remote encoder model) signal triggered;
- While <TriggerMode>=4, position set when detected Z signal(of remote encoder model).

High Speed Input

➤ ENC_TouchProbe

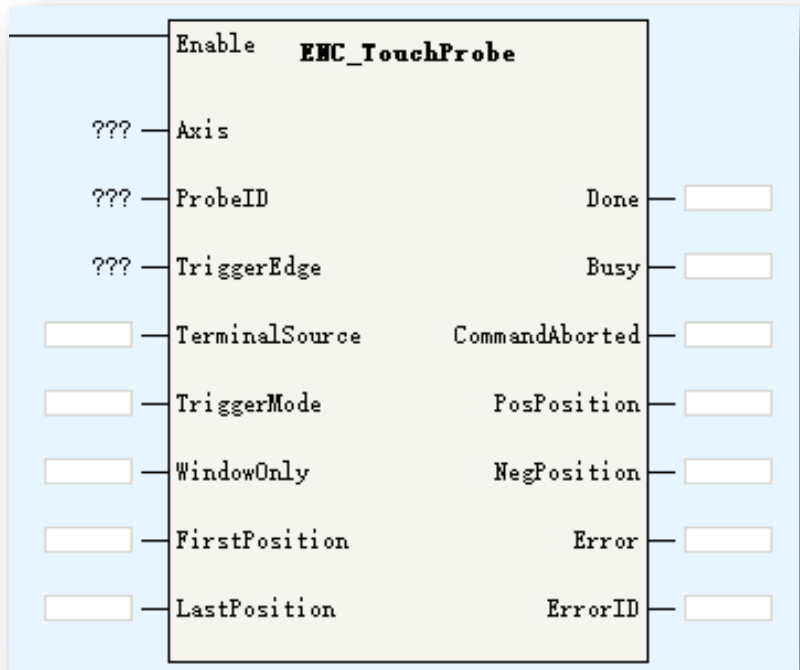

Parameters	Description
Axis	Encoder Axis name (bus encoder axis)
ProbeID	0: TP1 1:TP2
TriggerEdge	0: rising edge 1:falling edge 2:both of rising and falling edge
TerminalSource	TP trigger source: 0:DI 1:encoder Z signal
TriggerMode	0: single 1: continuous
WindowOnly	0: disabled window function, detect TP signal in any position 1: enable window function, detect TP signal in <FirstPosition, LastPosition> range
FirstPosition	TP window start position
LastPosition	TP window last position
PosPosition	Positive(rising edge) latch value
NegPosition	Negative(falling edge) latch value

ENC_TouchProbe is used to read the locked position value of external encoder while signal triggered without software delay, which means the latch position will not impacted by EtherCAT cycle and data transmission time.

High Speed Input

➤ ENC_TouchProbe

To using touch probe function, need select corresponding PDO in EtherCAT slave configuration(GL10-2HCE) and set the DI as touch probe input in axis configuration view.

The screenshot displays the software interface for configuring an EtherCAT slave (GR10-2HCE) and its axis settings. The left pane shows the Project Manager with the EtherCAT configuration tree expanded to GR10-2HCE. The main window shows the I/O Functional Mapping table, where several TPDO mapping parameters are selected. Two configuration dialog boxes are overlaid on the right side of the screen.

Direction	Name	Address	Subaddress	Bit Len
<input checked="" type="checkbox"/>	Output	Ch0 RPDO Mapping parameter 0	16#1700	16#00
<input type="checkbox"/>	Output	Ch0 RPDO Mapping parameter 1	16#1701	16#00
<input checked="" type="checkbox"/>	Output	Ch1 RPDO Mapping parameter 0	16#1710	16#00
<input type="checkbox"/>	Output	Ch1 RPDO Mapping parameter 1	16#1711	16#00
<input type="checkbox"/>	Output	Y00 compare out control	16#1720	16#00
<input type="checkbox"/>	Output	Y10 compare out control	16#1726	16#00
<input type="checkbox"/>	Output	Y00 x-y compare out control	16#1727	16#00
<input checked="" type="checkbox"/>	Input	Ch0 TPDO Mapping Parameter	16#1700	16#00
<input type="checkbox"/>	Input	Ch0 touch probe pos value TPDO mappin	16#1701	16#00
<input type="checkbox"/>	Input	Ch0 touch probe neg value TPDO mappin	16#1702	16#00
<input type="checkbox"/>	Input	Ch0 touch probe pos time stamp TPDO m	16#1703	16#00
<input type="checkbox"/>	Input	Ch0 touch probe pos time stamp TPDO m	16#1704	16#00
<input type="checkbox"/>	Input	Y00 compare status mapping parameter	16#1720	16#00
<input checked="" type="checkbox"/>	Input	Ch1 TPDO Mapping Parameter	16#1710	16#00
<input type="checkbox"/>	Input	Ch1 touch probe pos value TPDO mappin	16#1711	16#00
<input type="checkbox"/>	Input	Ch1 touch probe neg value TPDO mappin	16#1712	16#00
<input type="checkbox"/>	Input	Ch1 touch probe pos time stamp TPDO m	16#1713	16#00
<input type="checkbox"/>	Input	Ch0 touch probe pos time stamp TPDO m	16#1714	16#00
<input type="checkbox"/>	Input	Y10 compare status mapping parameter	16#1726	16#00

X00 Settings:

Selection: Probe Function 1

Level Logic: Positive Logic Inverse Logic

X01 Settings:

Selection: Probe Function 2

Level Logic: Probe Function 2 Inverse Logic

Reset

Preset

Gated

High Speed Input

➤ ENC_TouchProbe

While <Enable>=ON(rising edge), FB will lock the input parameters.

If <WindowOnly>=OFF, the window detection function will not work, the touch probe in full position range.

If <WindowOnly>=ON, the window detection function will be enabled, in this case:

While axis is in linear mode, only when the touch probe triggered in <FirstPosition> and <LastPosition> range, the position value will be latched.

While axis is in rotation mode, firstly do modulo operation to the <FirstPosition> and <LastPosition> based on the rotation cycle. For example, if <FirstPosition> is set as 540, the rotation cycle is 360, then the $\langle 540 \text{ Mod } 360 \rangle = 180$. After modulo operation, we get the modulo value FirstPosition_P and LastPosition_P.

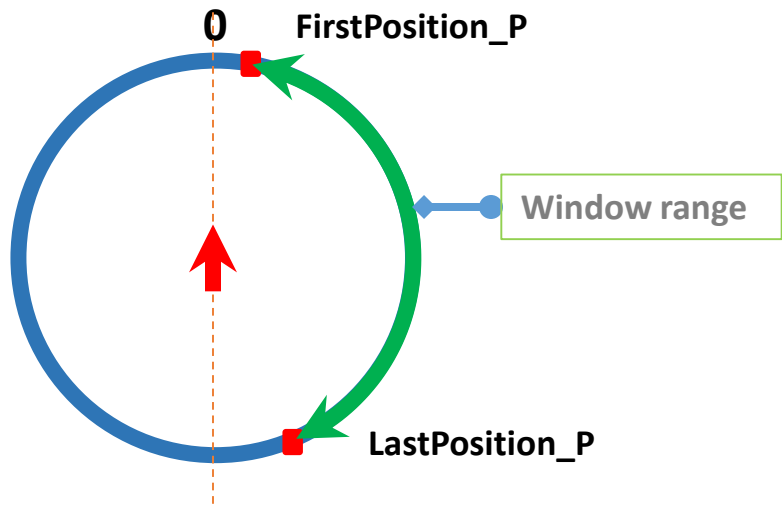

*While FirstPosition_P < LastPosition_P

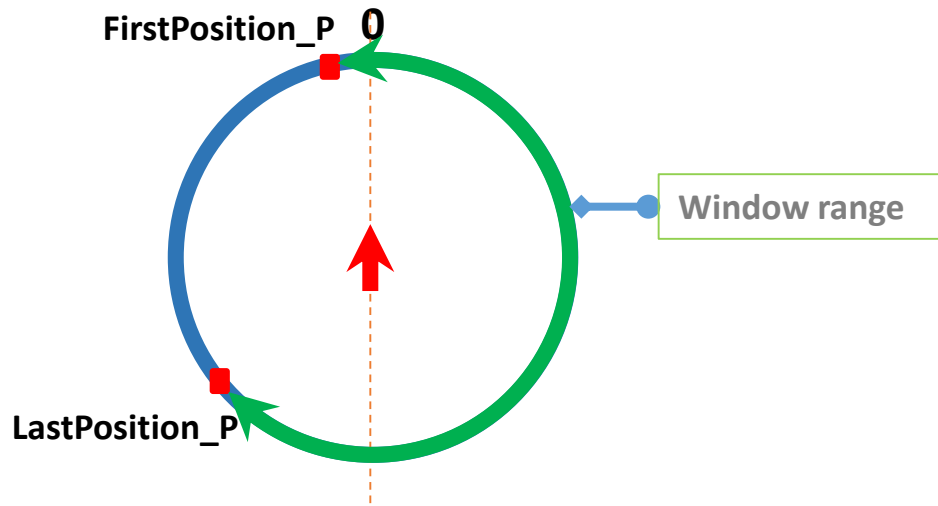

*While FirstPosition_P > LastPosition_P

High Speed Input

➤ ENC_ArrayCompare

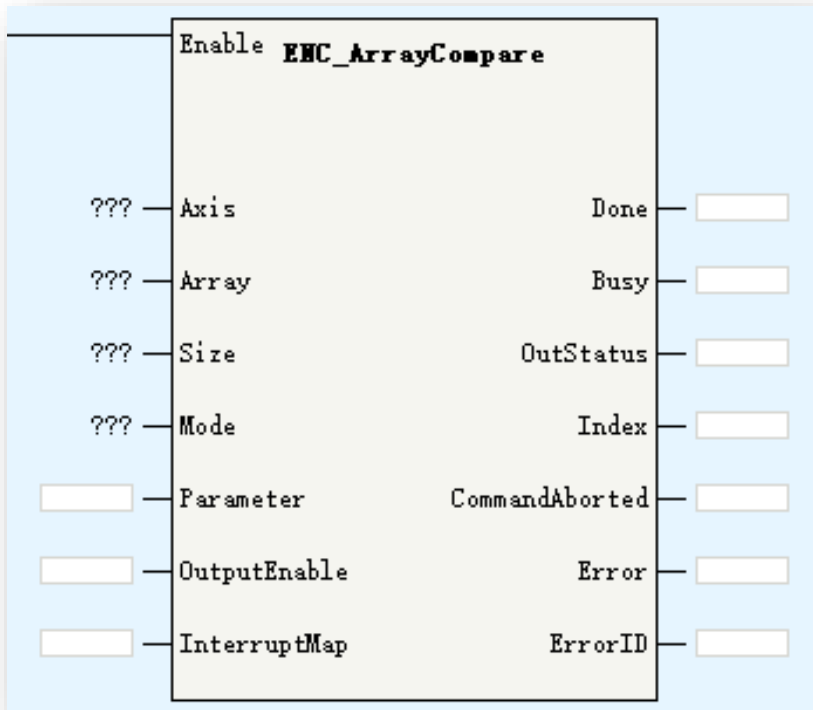

Parameters	Description
Axis	Encoder Axis name (bus encoder axis)
Array	Comparison array
Size	Comparison value quantities
Mode	0: reserved 1: time 2: pulse 3: electrical level
Parameter	Time mode: output valid time, unit: us Pulse mode: output pulse quantities Electrical level mode: original voltage level, 0 is low voltage, 1 is high voltage, every time up to comparison point, the output status will revert
OutputEnable	Reserved
InterruptMap	Reserved
OutStatus	Output signal status
Index	The upcoming comparison index

ENC_ArrayCompare is used to compare multi points and set corresponding output. The multi points are set in the array, and the comparison point quantities is set by the <Size>, be noted the <Size> value have to be less than the array length, or there could be array overflow(out of bound) when programming executing.

High Speed Input

➤ ENC_ArrayCompare

To use array comparison functionality, need select corresponding PDO in EtherCAT slave configuration(GL10-2HCE) and set the DO as <One dimensional comparison Output> in axis configuration view.

Take note: Y00 is used for channel 0, and Y10 is used for channel 1.

General Settings	<input type="button" value="Add"/> <input type="button" value="Edit"/> <input type="button" value="Delete"/> <input type="button" value="Collapse"/> <input type="button" value="Show All"/> <input checked="" type="checkbox"/> PDO Assign <input checked="" type="checkbox"/> PDO Conf				
Process Data	Input/Output	Name	Index	Subindex	Le
Startup Parameters	<input checked="" type="checkbox"/> Output	Ch0 RPDO Mapping parameter 0	16#1700	16#00	
	<input type="checkbox"/> Output	Ch0 RPDO Mapping parameter 1	16#1701	16#00	
I/O Functional Mapping	<input checked="" type="checkbox"/> Output	Ch1 RPDO Mapping parameter 0	16#1710	16#00	
	<input type="checkbox"/> Output	Ch1 RPDO Mapping parameter 1	16#1711	16#00	
Information	<input type="checkbox"/> Output	Y00 compare out control	16#1720	16#00	
	<input type="checkbox"/> Output	Y10 compare out control	16#1726	16#00	
State	<input type="checkbox"/> Output	Y00 x-y compare out control	16#1740	16#00	
	<input checked="" type="checkbox"/> Input	Ch0 TPDO Mapping Parameter	16#1B00	16#00	
	<input type="checkbox"/> Input	Ch0 touch probe pos value TPDO mappin	16#1B01	16#00	
	<input type="checkbox"/> Input	Ch0 touch probe neg value TPDO mappin	16#1B02	16#00	
	<input type="checkbox"/> Input	Ch0 touch probe pos time stamp TPDO m	16#1B03	16#00	
	<input type="checkbox"/> Input	Ch0 touch probe pos time stamp TPDO m	16#1B04	16#00	
	<input type="checkbox"/> Input	Y00 compare status mapping parameter	16#1B05	16#00	
	<input checked="" type="checkbox"/> Input	Ch1 TPDO Mapping Parameter	16#1B10	16#00	
	<input type="checkbox"/> Input	Ch1 touch probe pos value TPDO mappin	16#1B11	16#00	
	<input type="checkbox"/> Input	Ch1 touch probe neg value TPDO mappin	16#1B12	16#00	
	<input type="checkbox"/> Input	Ch1 touch probe pos time stamp TPDO m	16#1B13	16#00	
	<input type="checkbox"/> Input	Ch0 touch probe pos time stamp TPDO m	16#1B14	16#00	
	<input type="checkbox"/> Input	Y10 compare status mapping parameter	16#1B15	16#00	

Y00 Settings:

Selection:

Level Logic:

Break Out:

Set value: OFF ON

Y01 Settings:

Selection:

Level Logic: Positive Logic Inverse Logic

High Speed Input

➤ ENC_StepCompare

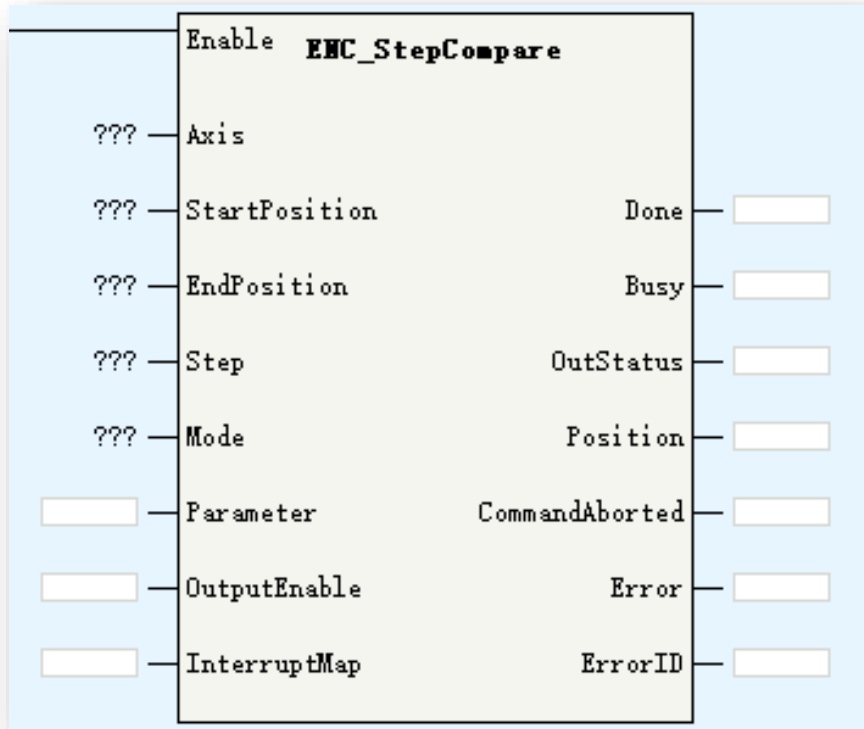

Parameters	Description
Axis	Encoder Axis name (bus encoder axis)
StartPosition	Comparison start position
EndPosition	Comparison end position
Step	Step
Mode	Comparison mode: 0: reserved 1: time mode 2: pulse mode 3: electrical level mode
Parameter	Time mode: output valid time, unit: us Pulse mode: output pulse quantities Electrical level mode: original voltage level, 0 is low voltage, 1 is high voltage, every time up to comparison point, the output status will revert
OutputEnable	Reserved
InterruptMap	Reserved
OutStatus	Output signal status
Position	The upcoming comparison value

ENC_Counter is used to compare multi position in a certain position range. The comparison space is set by the <Step>, the comparison range is set by the <StartPosition> and <EndPosition>.

High Speed Input

➤ ENC_StepCompare

In linear mode:

While <StartPosition> less than <EndPosition>, <Step> should be positive number, and while <StartPosition> is greater than <EndPosition>, <Step> should be negative number.

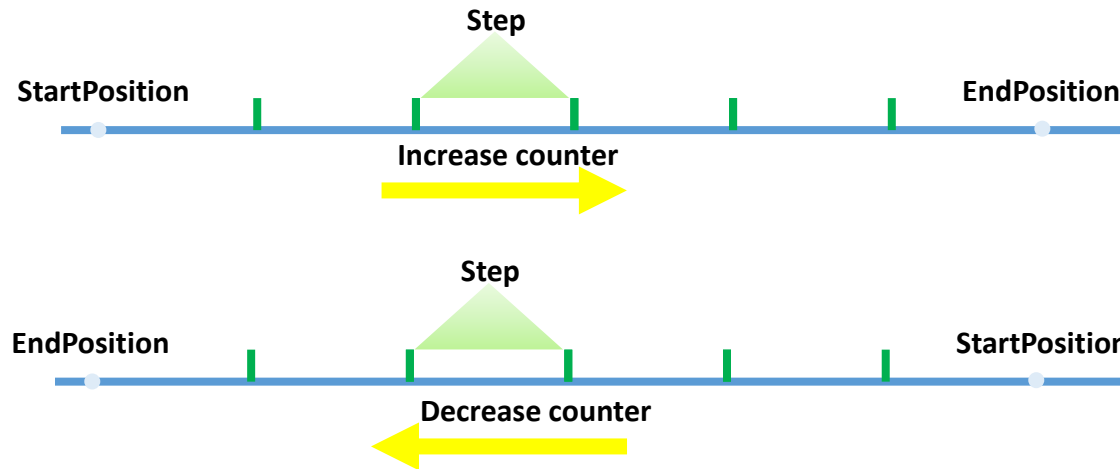

In rotation mode, same logic with linear mode:

While <StartPosition> less than <EndPosition>, <Step> should be positive number, and while <StartPosition> is greater than <EndPosition>, <Step> should be negative number.

➤ **ENC_StepCompare**

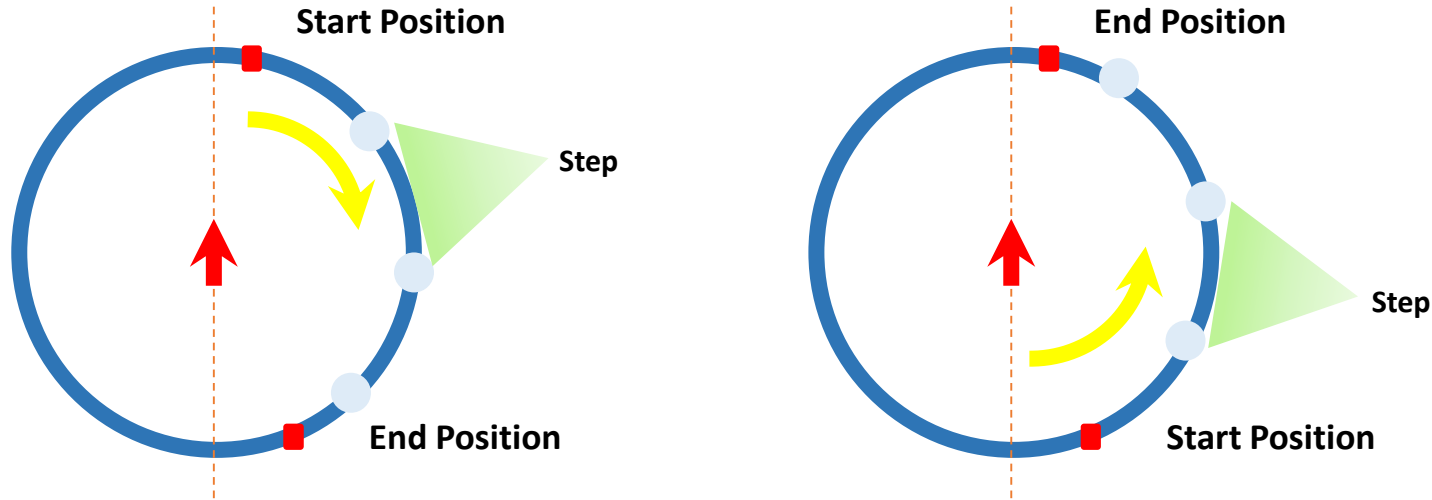

To use ENC_StepCompare, need select corresponding PDO in EtherCAT slave configuration(GL10-2HCE) and set the DO as <One dimensional comparison Output> in axis configuration view.

[The sets is same with ENC ArrayCompare.](#)

High Speed Input

➤ ENC_GroupArrayCompare

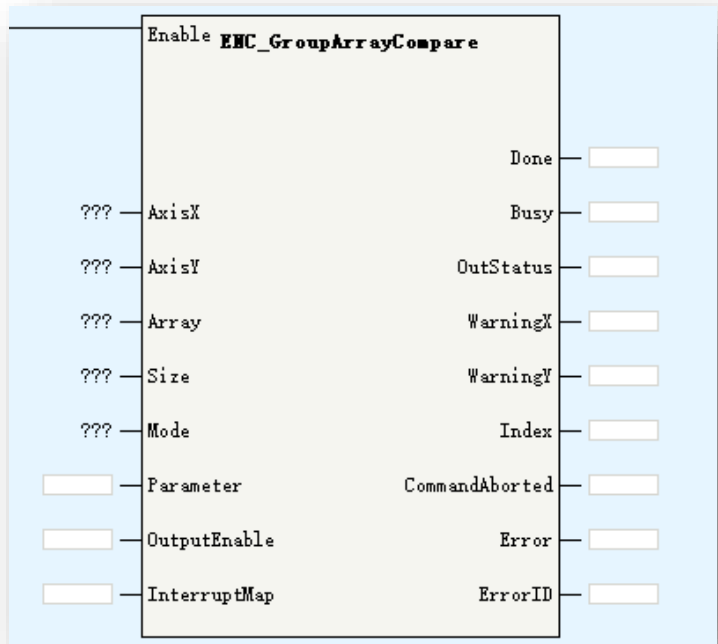

ENC_GroupArrayCompare is 2 dimension multi points comparison function block. It need be used with GR10-2HCE mode, and select channel 0 as X axis, channel 1 as Y axis.

The multi points are set in the array, and the comparison point quantities is set by the <Size>, be noted the <Size> value have to be less than the array length, or there could be array overflow(out of bound) when programming executing.

Parameters	Description
AxisX	Encoder Axis X name (bus encoder axis)
AxisY	Encoder Axis Y name (bus encoder axis)
Array	Comparison array(2 dimension array)
Size	Comparison value quantities
Mode	Comparison mode: 0:reserved 1:time mode 2:reserved 3: electrical level mode
Parameter	Time mode: output valid time, unit:us Electrical level mode: original voltage level, 0 is low voltage, 1 is high voltage, every time up to comparison point, the output status will revert
OutputEnable	Reserved
InterruptMap	Reserved
OutStatus	Output signal status
WarningX	X axis warning output
WarningY	Y axis warning output
Index	The uncoming comparison index

High Speed Input

➤ ENC_GroupArrayComapre

To use 2 dimension array comparison functionality, need select corresponding PDO in EtherCAT slave configuration(GL10-2HCE) and set the DO as <Two dimensional comparison Output> in axis configuration view.

Take note: Y00 is used for channel 0, and Y10 is used for channel 1.

General Settings	<input type="button" value="Add"/> <input type="button" value="Edit"/> <input type="button" value="Delete"/> <input type="button" value="Collapse"/> <input type="button" value="Show All"/> <input checked="" type="checkbox"/> PDO Assign <input checked="" type="checkbox"/> PDO Config PDO Data Size Output(Byte):20 Input(Byte):32							
Process Data	Input/Output	Name	Index	Subindex	Length	Sign	SM	Type
Startup Parameters	<input checked="" type="checkbox"/> Output	Ch0 RFDO Mapping parameter 0	16#1700	16#00	10	Editabl	2	
	<input type="checkbox"/> Output	Ch0 RFDO Mapping parameter 1	16#1701	16#00	12	F		
I/O Functional Mapping	<input checked="" type="checkbox"/> Output	Ch1 RFDO Mapping parameter 0	16#1710	16#00	10	Editabl	2	
	<input type="checkbox"/> Output	Ch1 RFDO Mapping parameter 1	16#1711	16#00	12	F		
Information	<input type="checkbox"/> Output	Y00 compare out control	16#1720	16#00	18	F		
	<input type="checkbox"/> Output	Y10 compare out control	16#1726	16#00	18	F		
State	<input checked="" type="checkbox"/> Input	Y00 x-y compare out control	16#1740	16#00	18	F		
	<input checked="" type="checkbox"/> Input	Ch0 TPDO Mapping Parameter	16#1B00	16#00	16	Editabl	3	
	<input type="checkbox"/> Input	Ch0 touch probe pos value TPDO mappin	16#1B01	16#00	10	F		
	<input type="checkbox"/> Input	Ch0 touch probe neg value TPDO mappin	16#1B02	16#00	8	F		
	<input type="checkbox"/> Input	Ch0 touch probe pos time stamp TPDO m	16#1B03	16#00	10	F		
	<input type="checkbox"/> Input	Ch0 touch probe pos time stamp TPDO m	16#1B04	16#00	10	F		
	<input type="checkbox"/> Input	Y00 compare status mapping parameter	16#1B05	16#00	10	F		
	<input checked="" type="checkbox"/> Input	Ch1 TPDO Mapping Parameter	16#1B06	16#00	16	Editabl	3	
	<input type="checkbox"/> Input	Ch1 touch probe pos value TPDO mappin	16#1B07	16#00	10	F		
	<input type="checkbox"/> Input	Ch1 touch probe neg value TPDO mappin	16#1B08	16#00	8	F		

To set the comparison range. See next slide.

Y00 Settings:

Selection **Two dimensional comparison output**

Level Logic Positive Logic Inverse Logic

Break Output status Keep status Output set value

Set value OFF ON

Two dimensional comparison output:

X Axis permissible error 1.00 Unit

Y Axis permissible error 1.00 Unit

X Axis alarm deviation 2.00 Unit

Y Axis alarm deviation 2.00 Unit

Permissible error must less than alarm deviation

➤ ENC_GroupArrayComapre

(Tx, Ty) is the target comparison point, (Mx, My) is the permission error, (Nx, Ny) is the alarm deviation.
 If one axis already get into permission output area but the other axis not get into alarm buffer area, the corresponding of <WarningX> or <WarningY> will be valid until the other axis get into alarm buffer area.
 If the point is in non detection area or alarm buffer area, there is no signal output(alarm output or comparison output)

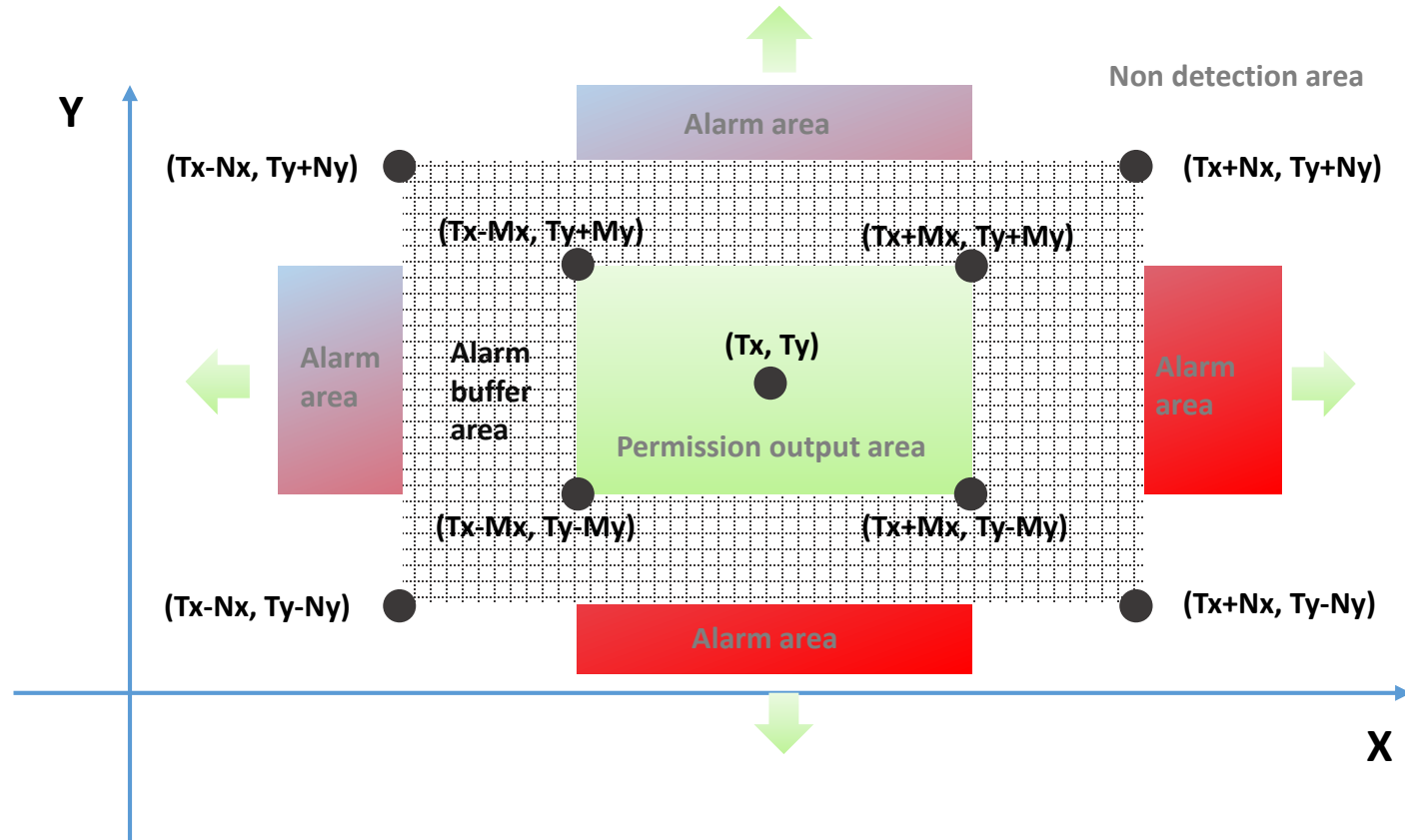

➤ ENC_ReadStatus

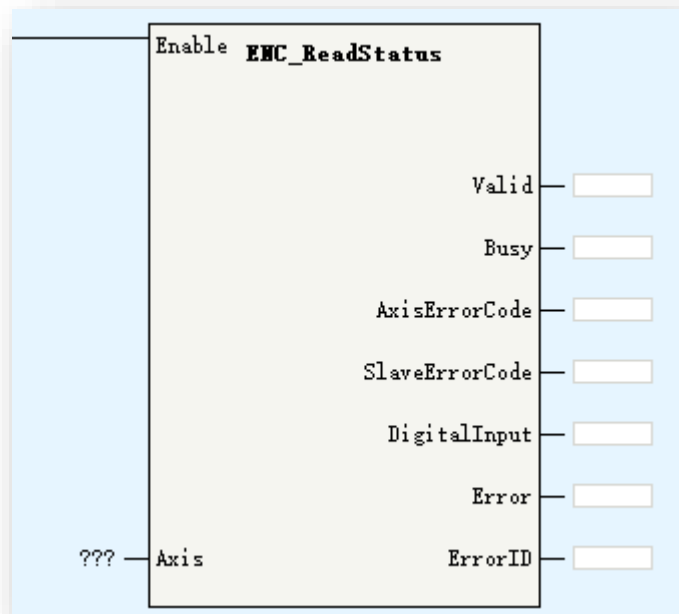

Parameters	Description
Axis	Encoder Axis name (bus encoder axis)
Valid	Valid
AxisErrorCode	Axis error code
SlaveErrorCode	Drive error code
DigitalInput	Bit0: CHn-X0 Bit1:CHn-X1 Bit2: CHn-X2 Bit3:CHn-X3

ENC_ReadStatus is used to read bus encoder axis status.

<AxisErrorCode> is bus encoder axis error code, refer the [H5U error code](#).

<DriveErrorCode> is GR10-2HCE model error code, refer GR10-2HCE application manual.

High Speed Input

➤ ENC_DigitalOutput

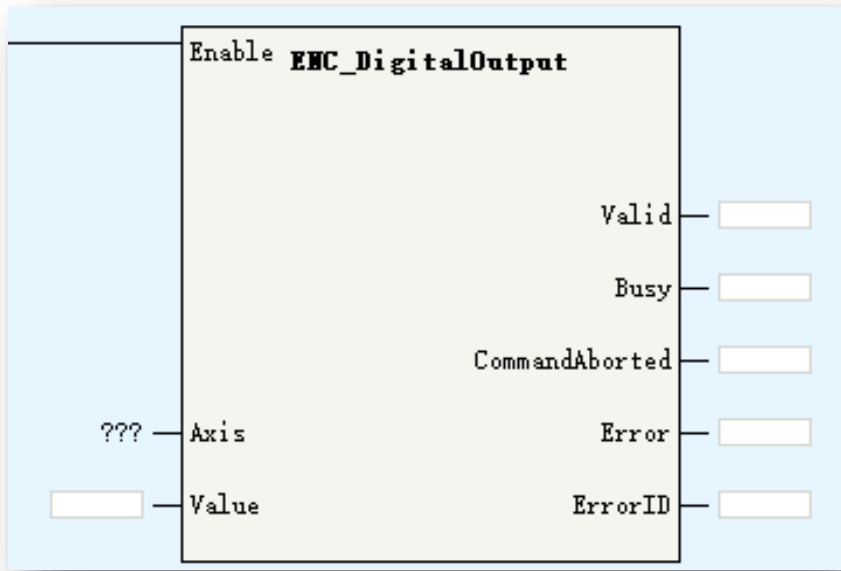

Parameters	Description
Axis	Encoder Axis name (bus encoder axis)
Value	Bit0:CHn-Y0 Bit1:CHn-Y1 Bit2:CHn-Y2
Valid	Output valid

ENC_DigitalOutput is used to set GR10-2HCE output.
 While the axis is bind with CH0, the output is Y0/Y1/Y2,
 While the axis is bind with CH1, the output is Y10/Y11/Y12.

➤ **ENC_ResetCompare**

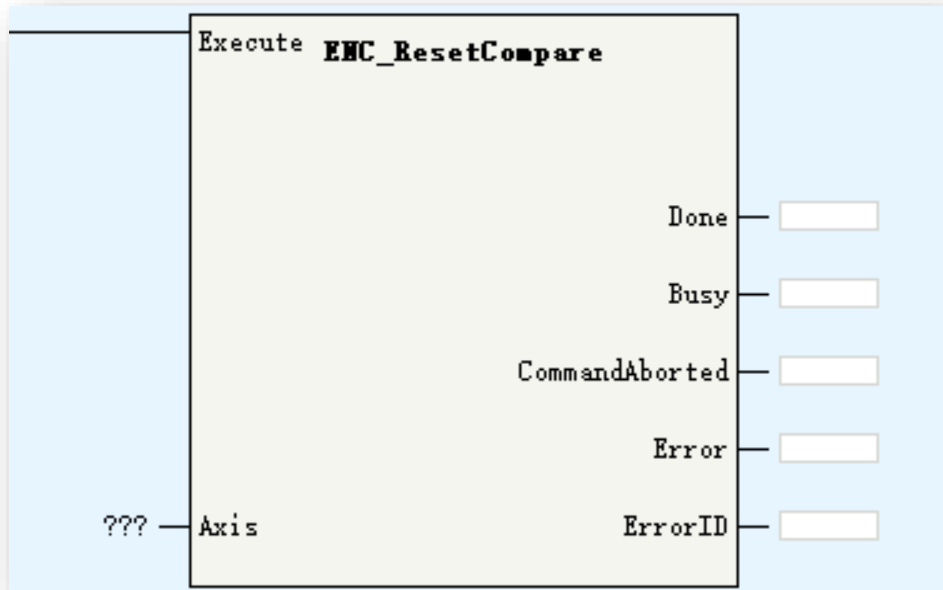

Parameters	Description
Axis	Encoder Axis name (bus encoder axis)

ENC_ResetCompare is used to reset comparison output of ENC_StepCompare/ENC_ArrayCompare/ENC_GroupArrayCompare. While ENC_ResetCompare executing, if ENC_StepCompare/ENC_ArrayCompare/ENC_GroupArrayCompare not complete, the command will be aborted, the the comparison output will be reset.

Take note:

If the comparison mode is electrical level mode, the comparison output will keep in a certain status(could be ON) even though corresponding comparison command already done, at this time, using ENC_ResetCompare to reset output status to OFF.

High Speed Input

➤ HC_Preset

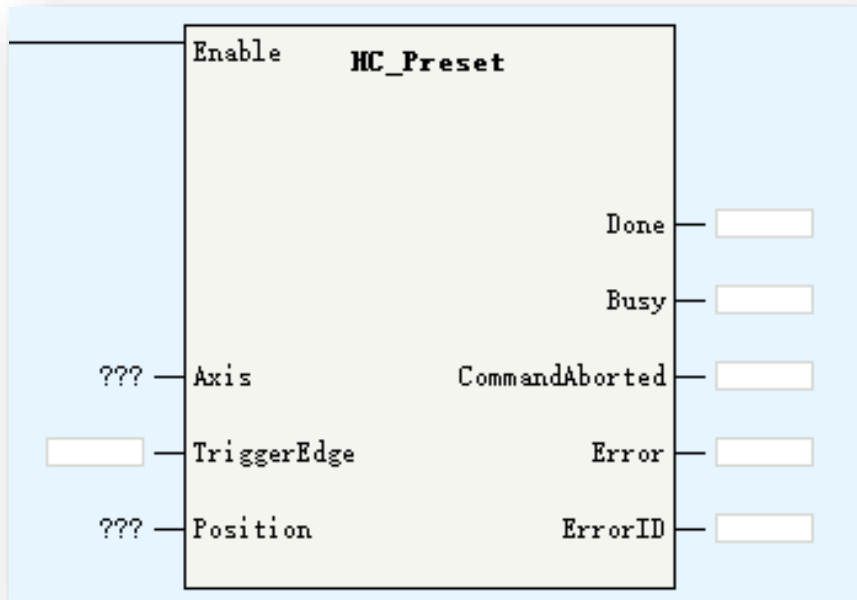

Parameters	Description
Axis	Encoder Axis name/ID (local encoder axis)
TriggerEdge	0: trigger in FB rising edge 1: Input signal rising edge 2: input signal falling edge 3: input signal rising or falling edge
Position	Preset value

HC_Preset is used to set preset value for local encoder counter.
 Take note:
 If <TriggerEdge> is not 0, need configure <Preset Setting> in axis configuration view.

Preset Setting Preset Enable Input terminal: X6

High Speed Input

➤ HC_Counter

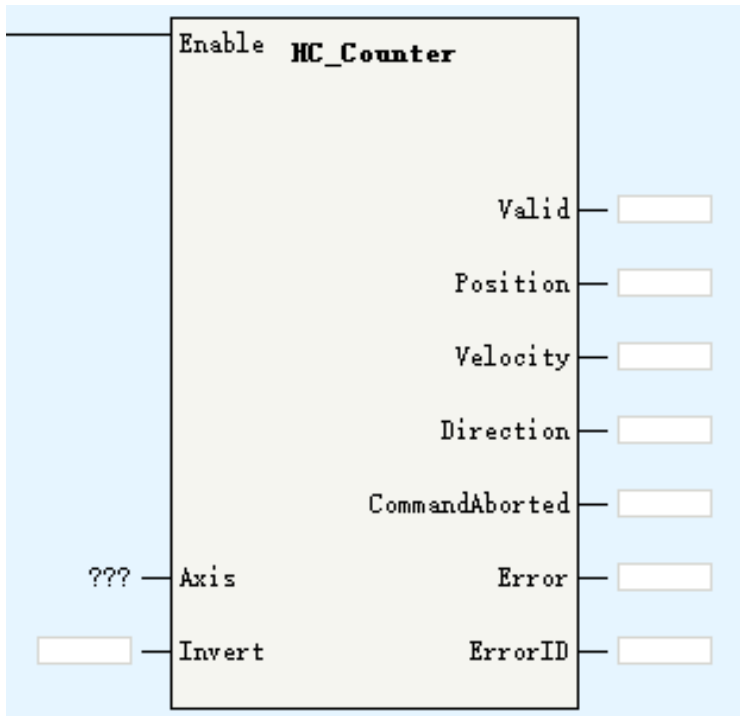

Parameters	Description
Axis	Encoder Axis name/ID (local encoder axis)
Invert	Invert count direction
Valid	Encoder input valid
Position	Current position
Velocity	Current velocity
Direction	Current direction

HC_Counter is used to enable the bus encoder axis.
 The invert definition in different signal format show in the table.

Invert	A/B	Pulse/Direction	CW/CCW	Single source
0	Increase: phase A overtakes phase B Decrease: phase B overtakes phase A	Increase: Direction high level Decrease: Direction low level	Increase: Phase A Decrease: Phase B	Increase
1	Increase: phase B overtakes phase A Decrease: phase A overtakes phase B	Increase: Direction low level Decrease: Direction high level	Increase: Phase B Decrease: Phase A	Decrease

High Speed Input

➤ HC_TouchProbe

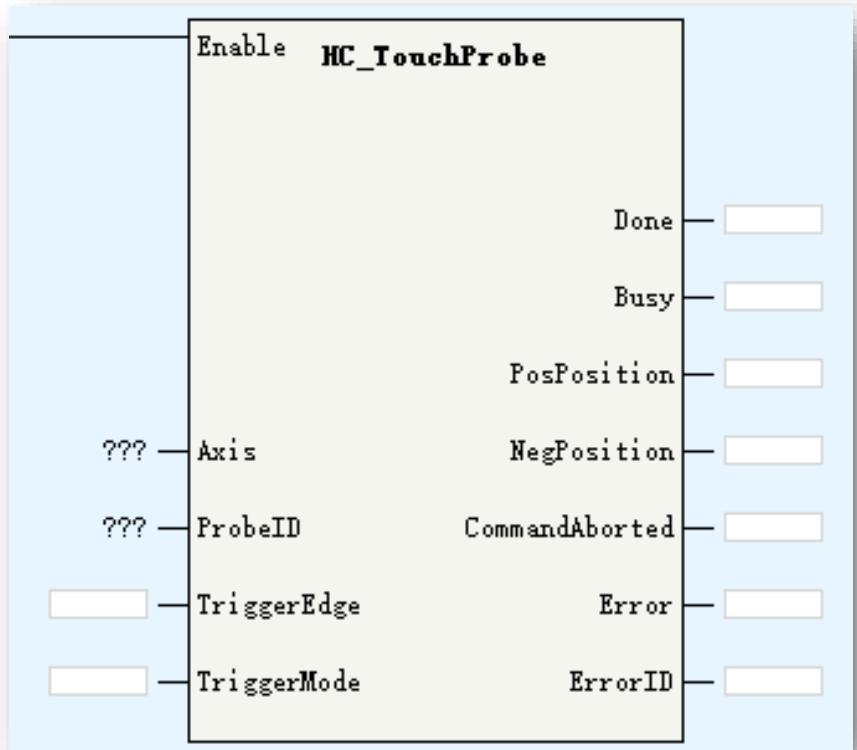

Parameters	Description
Axis	Encoder Axis name/ID (local encoder axis)
ProbeID	Touch probe ID: 0: TP1 1:TP2
TriggerEdge	1: rising edge 2: falling edge 3: rising edge and falling edge
TriggerMode	0: single trigger 1: continuous trigger
PosPosition	Rising edge latch position
NegPosition	Falling edge latch position

HC_TouchProbe is used to read the locked position value of local encoder while signal triggered without software delay.

High Speed Input

➤ HC_Compare

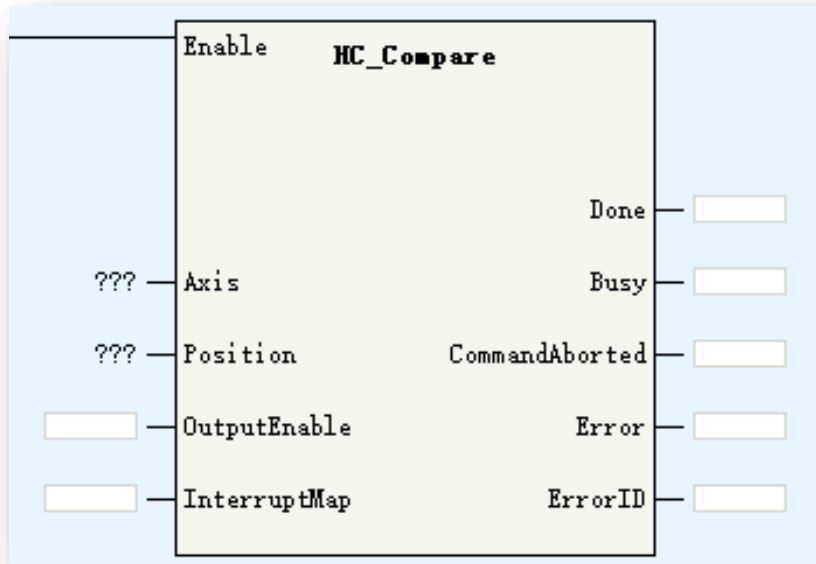

Parameters	Description
Axis	Encoder Axis name (bus encoder axis)
Position	Comparison position
OutputEnable	0: don't use hardware output 1: use hardware output
InterruptMap	While up to comparison value: 0: no interruption 1: interruption 1 triggered 2: interruption 2 triggered ... 16: interruption 16 triggered

HC_Compare is used to set comparison value for local encoder axis and it support comparison output(map to hardware output) and trigger an interruption event.

High Speed Input

➤ HC_ArrayCompare

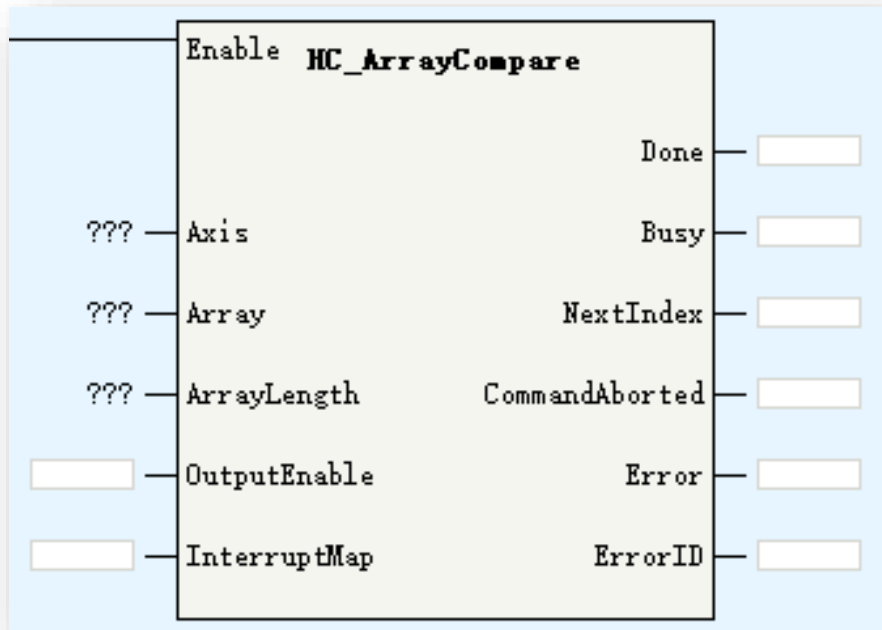

Parameters	Description
Axis	Encoder Axis name (bus encoder axis)
Array	Comparison position array
ArrayLength	Comparison position array length
OutputEnable	0: don't use hardware output 1: use hardware output
InterruptMap	While up to comparison value: 0: no interruption 1: interruption 1 triggered 2: interruption 2 triggered ... 16: interruption 16 triggered
NextIndex	The upcoming comparison index

HC_ArrayCompare is used to set multi comparison value for local encoder axis and it support comparison output(map to hardware output) and trigger an interruption event.

High Speed Input

➤ HC_StepCompare

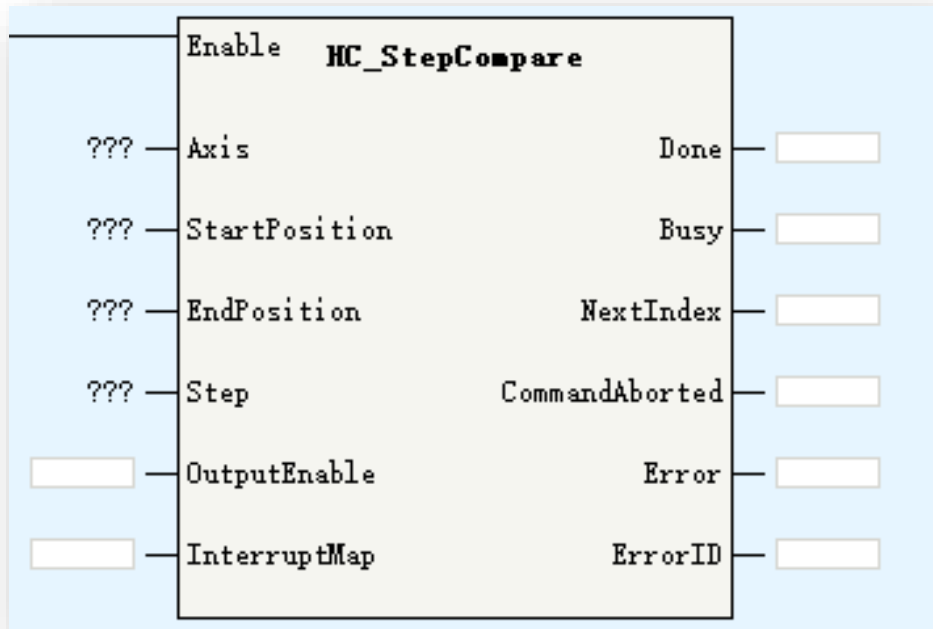

Parameters	Description
Axis	Encoder Axis name (bus encoder axis)
StartPosition	Comparison start position
EndPosition	Comparison end position
Step	Comparison step
OutputEnable	0: don't use hardware output 1: use hardware output
InterruptMap	While up to comparison value: 0: no interruption 1: interruption 1 triggered 2: interruption 2 triggered ... 16: interruption 16 triggered
NextIndex	Positive limit valid in linear mode

HC_StepCompare is used to compare multi position in a certain position range. The comparison space is set by the <Step>, the comparison range is set by the <StartPosition> and <EndPosition>. Besides, it support comparison output(map to hardware output) and trigger an interruption event.

For more parameters introduction, please [refer to ENC_StepCompare](#).

Functionality Features

IT7000 & H5U simulation

IT7000 support simulation with inovance H5U series PLC without hardware connection. This functionality will help users to improve project development/commissioning efficiency.

➤ H5U

Software: Autoshop V4.2.0.0(or above): <https://www.inovance.com/hc/allResult?key=Autoshop>
 Step1: Create a new project and compile all without error.

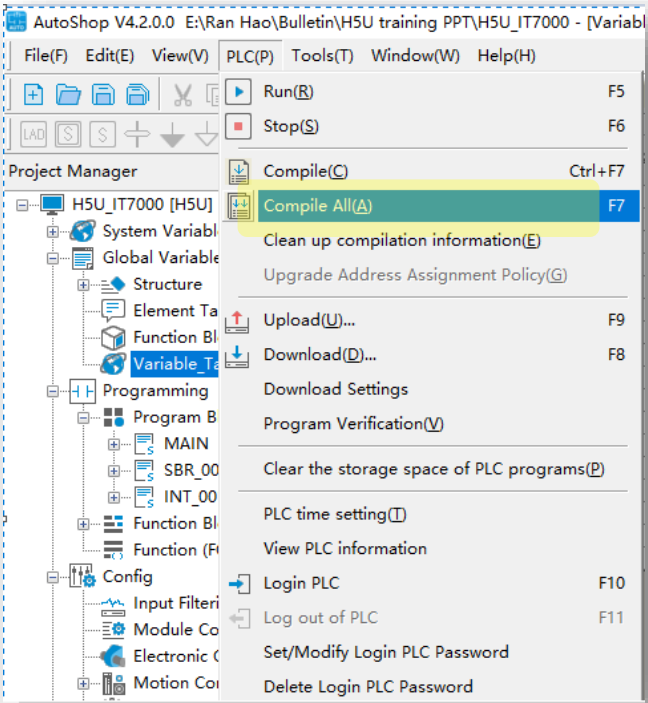

IT7000 & H5U simulation

➤ H5U

Step2: Open the variable table and right click to export HMI variables. The export variable table should be .csv format.

The screenshot shows the HMI software interface. On the left, the Project Manager tree is expanded to 'Variable Table'. The main window displays a table of variables. A context menu is open over the table, with 'Export HMI Monitoring Variable Table(H)' highlighted. A file explorer window is also open, showing the file 'h5u variable.csv' selected for saving.

NO.	Variable...	Data Type	Initial Value	Power Down Hold	Comment	Element Addr.	Length	CurValue
1	axMCPower_...	BOOL[31]	...	Non Retained			nBitLen: 31	

IT7000 & H5U simulation

➤ IT7000

Step1: Add a new connection, select 'H5U TCP Monitoring Protocol' and set the slave device IP address as 127.0.0.1.

The screenshot displays the Inovance software interface with the following components:

- Left Panel (Navigation):**
 - Screens(1/256)
 - Communication
 - Connections (highlighted)
 - Cycles
 - Tags(4/128)
 - Show All Tags
 - Add Tag Group
 - System Tags
 - xxx
 - H5U
 - H5U SYS_INFO
 - MQTT
 - Alarm Management
 - Recipes(0/100)
 - Historical Data
 - Scripts(0/100)
- Center Panel (Table):**

+	Name	Number	Communication protocol	Default status	Address edit ...	Comment
1	Connection_3	1	H5U TCP Monitor Protocol	Online	Decimal	
- Right Panel (Device Selection):**
 - Inovance
 - H1U/H2U/H3U Series
 - H5U Series
 - H5U Qlink TCP Protocol
 - H5U Qlink Protocol
 - H5U TCP Monitor Protocol (highlighted)
 - AM600 Series
 - AC810 Series
 - Transducer Series
 - Servo Series
 - IT7000 Series
 - Omron
 - Siemens
 - Mitsubishi
 - Modicon
 - Delta DVP

Interface
 Ethernet

HMI as master device

Timeout: 100 ms

Comm. Delay: 0 ms

Response Delay: 0 ms

Resend Counts: 3

Slave Device

IP Address: 127.0.0.1

Port: 12939

Slave address: 1

Address Interval(words): 5

Max Read(words): 120

Max Write(words): 120

IT7000 & H5U simulation

➤ IT7000

Step2: Add a new tag group, select and right click to import variables.

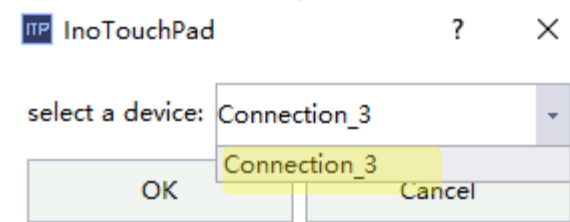
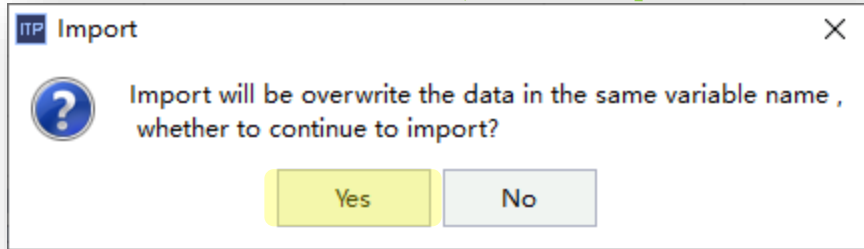
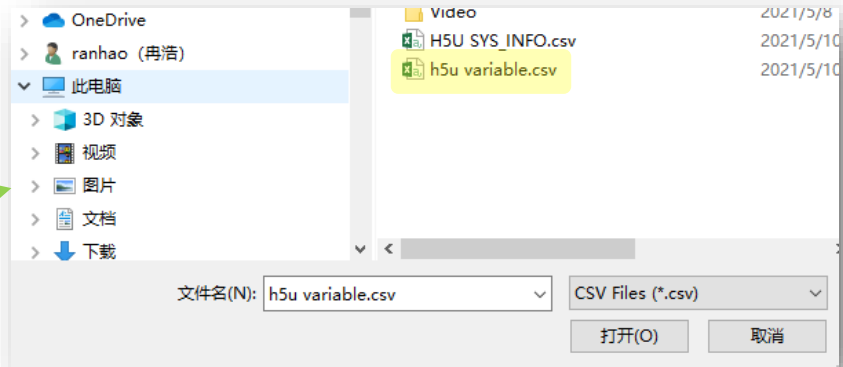
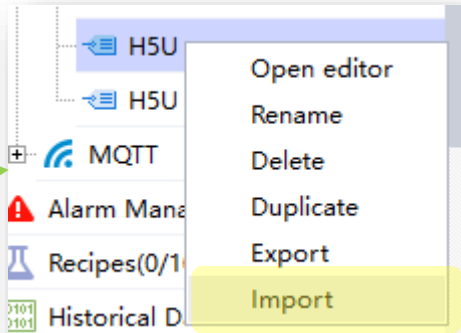
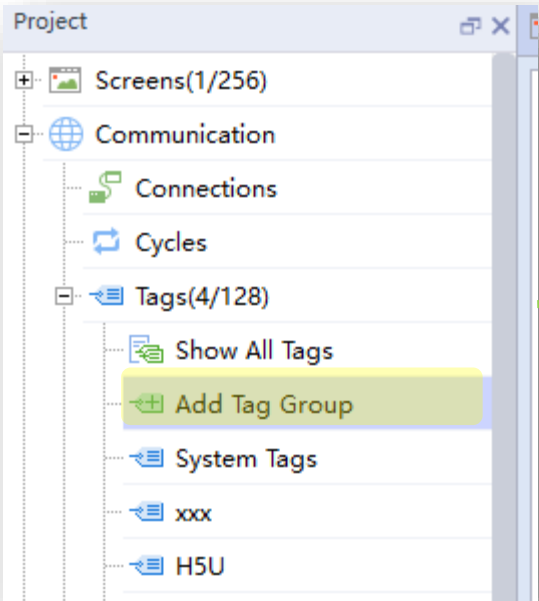

IT7000 & H5U simulation

➤ IT7000

Step3: Configure/or map H5U variable to HMI controls

The screenshot displays two control panels: MC_Power and MC_Jog. The MC_Power panel includes buttons for Enable (OFF), Status (OFF), Busy (OFF), Error (OFF), and ErrorID (0000). The MC_Jog panel includes buttons for Enable (OFF), Busy (OFF), JogFWD (OFF), and CmdAbort (OFF). Below these panels is a configuration window for 'Button_1(BitButton)'. The 'General' tab is active, showing 'Read Tag' set to 'axMCPower_Enable[0]' and 'Write' mode set to 'Invert'.

Control	Value
MC_Power Enable	OFF
MC_Power Status	OFF
MC_Power Busy	OFF
MC_Power Error	OFF
MC_Power ErrorID	0000
MC_Jog Enable	OFF
MC_Jog Busy	OFF
MC_Jog JogFWD	OFF
MC_Jog CmdAbort	OFF

Button_1(BitButton) General

Read

Read Tag: axMCPower_Enable[0]

Output Reverse

Write

Read/Write Tag Same

Mode: Invert

IT7000 & H5U simulation

Start to simulation.

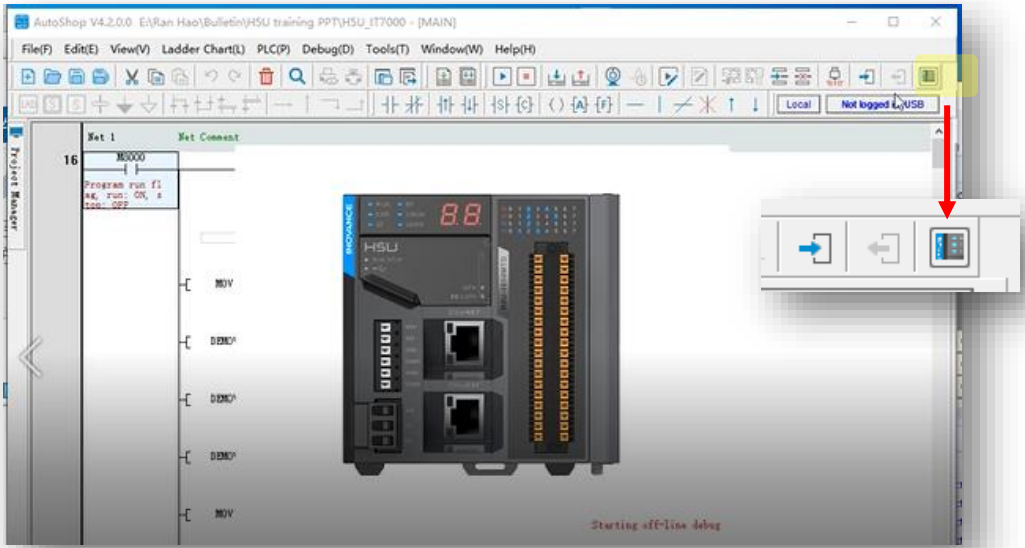

effect

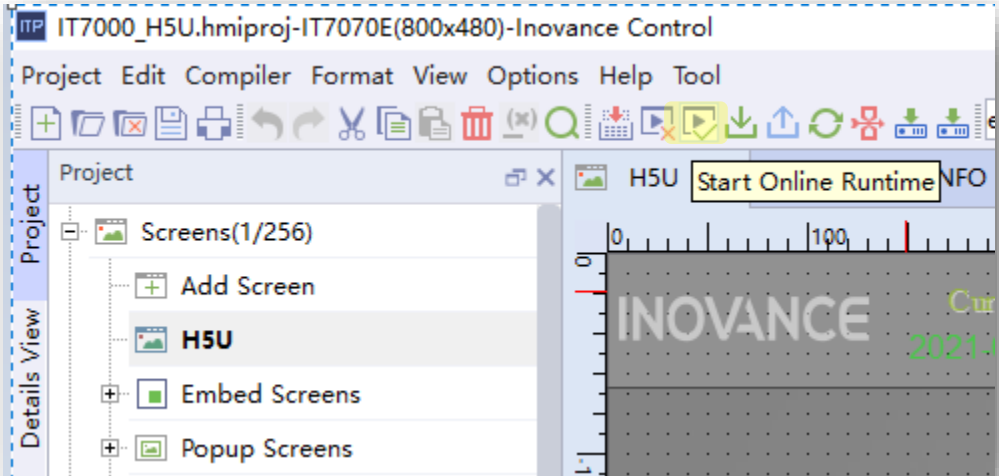
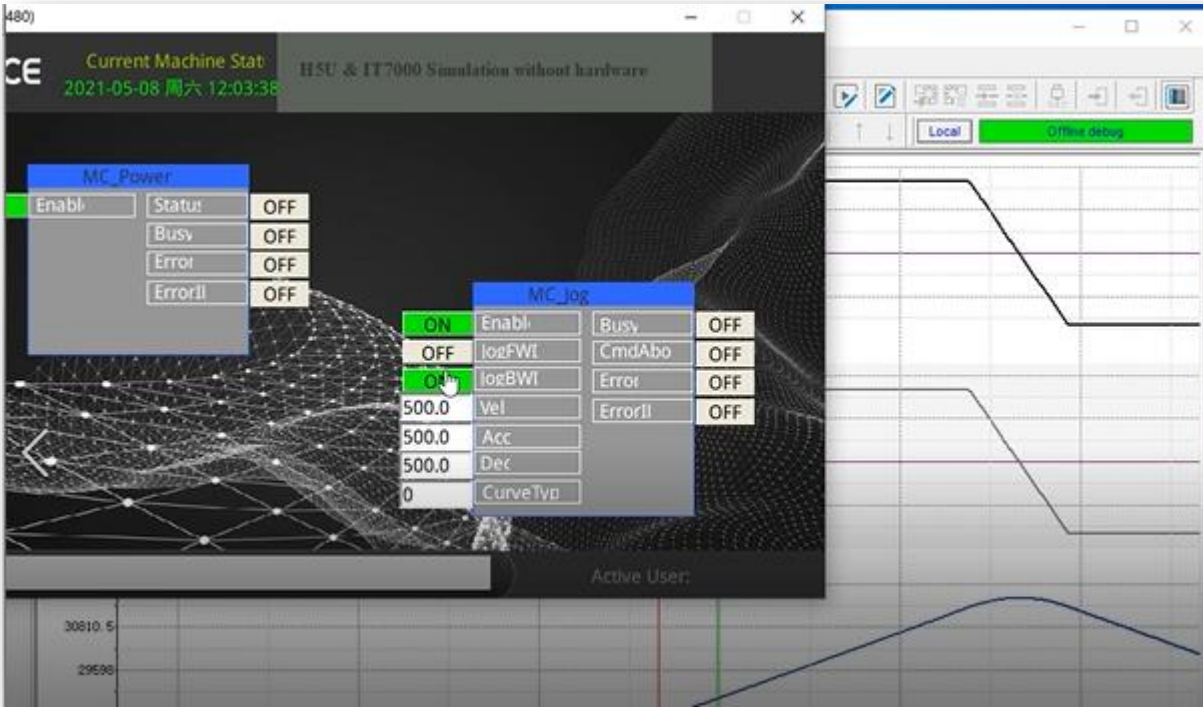

Online Modification

H5U support online modification, which allows users to modify program while the PLC is running. The online modification will not impact the PLC status.

Before using this function, make sure the connection between PC and PLC is good.

The operation process show as below:

1> Select <PLC> → <Online Edit Mode>

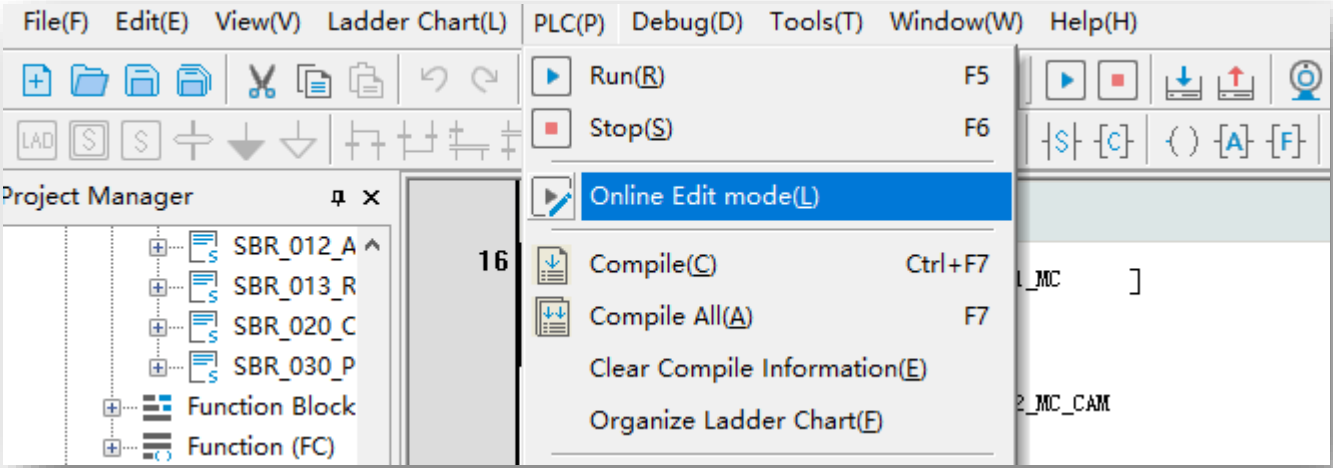

Online Modification

2> While get into <Online Edit Mode>, if the current opened project is different than the project in controller, the indication dialog box will pop up, at this time, users need to check if they open the correct project.

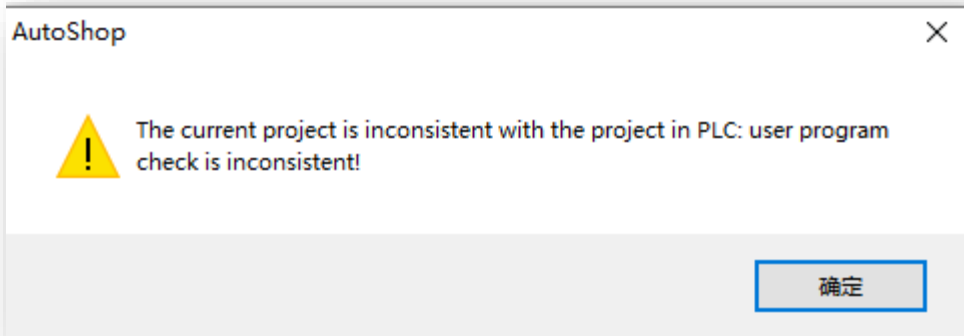

3> Modify the project according to real demands, after that, click download button to download the modified program to PLC. Take note, the PLC will not stop running during this process.

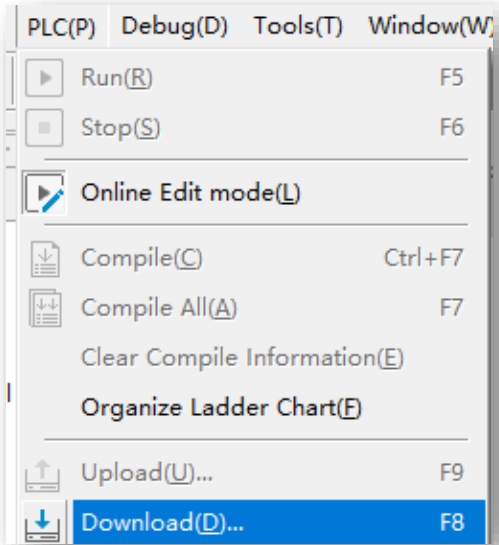

Online Modification

[Back to Contents](#)

4> Check the output window to check if the online modification succeed.

Information Output Window

```
AutoShop: Communication Message
Information(2021-11-02 15:04:00) Download successful!
Information(2021-11-02 15:04:00) Online Modification command executed correctly
```

➤ FB

FB is function block which used to build specified program as a general program block and can be re-used in program. Using the encapsulated function block, users can save the development time and improve the programming efficiency and quality.

While a FB execute, there could be some variables used in FB, system will assign internal memory for these variables, and these internal variables will decide the FB status or features. For the same input parameters, there could be different output parameters, the output result depends on the FB status(or the internal variables).

The usage of FB show as below:

1> Create a new function block--<Programming>→<Function Block> right click and select <New>, then set the function block name in the pop up window.

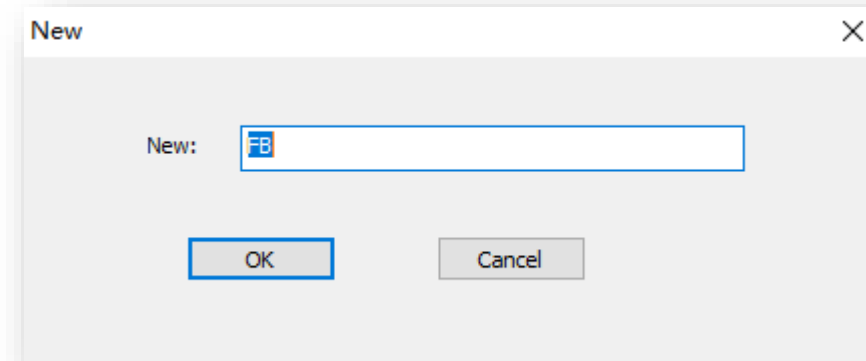
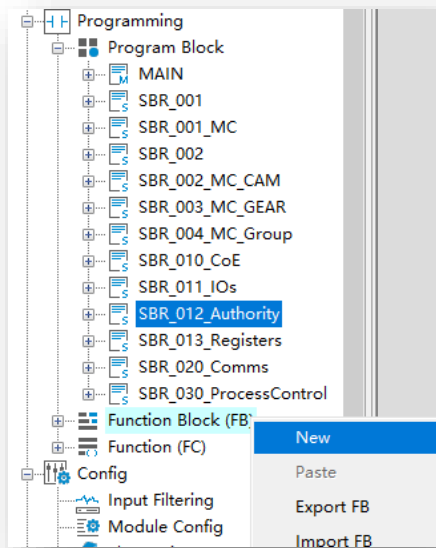

➤ **FB**

2> Develop function block program.

FB support VAR/IN/OUT/INOUT type variable. VAR is internal usage variable, IN/OUT/INOUT is the input/output parameter of FB, besides, FB can use H5U soft elements(D/M/R...) as global variable, and at the same time, FB support <Retained> type variable.

NO.	I/O Type	Name	Data Type	Initial Value	Power Down Hold	Comment
1	IN	Input	BOOL	OFF	Non Retained	
2	OUT	Output	BOOL	OFF	Non Retained	
3	OUT	Result	BOOL	OFF	Non Retained	
4						

Net 1 网络注释

En PARAS

"96ED21F7" AuthCode Result Result

Net 2 网络注释

Input (Output)

➤ **FB**

3> Using FB in program

FB can be used in program by selecting from tool box <FB>, or directly input FB name in input box.

Take note FB also support to be used in another FB, H5U FB support multistage nested(up to 8 stages).

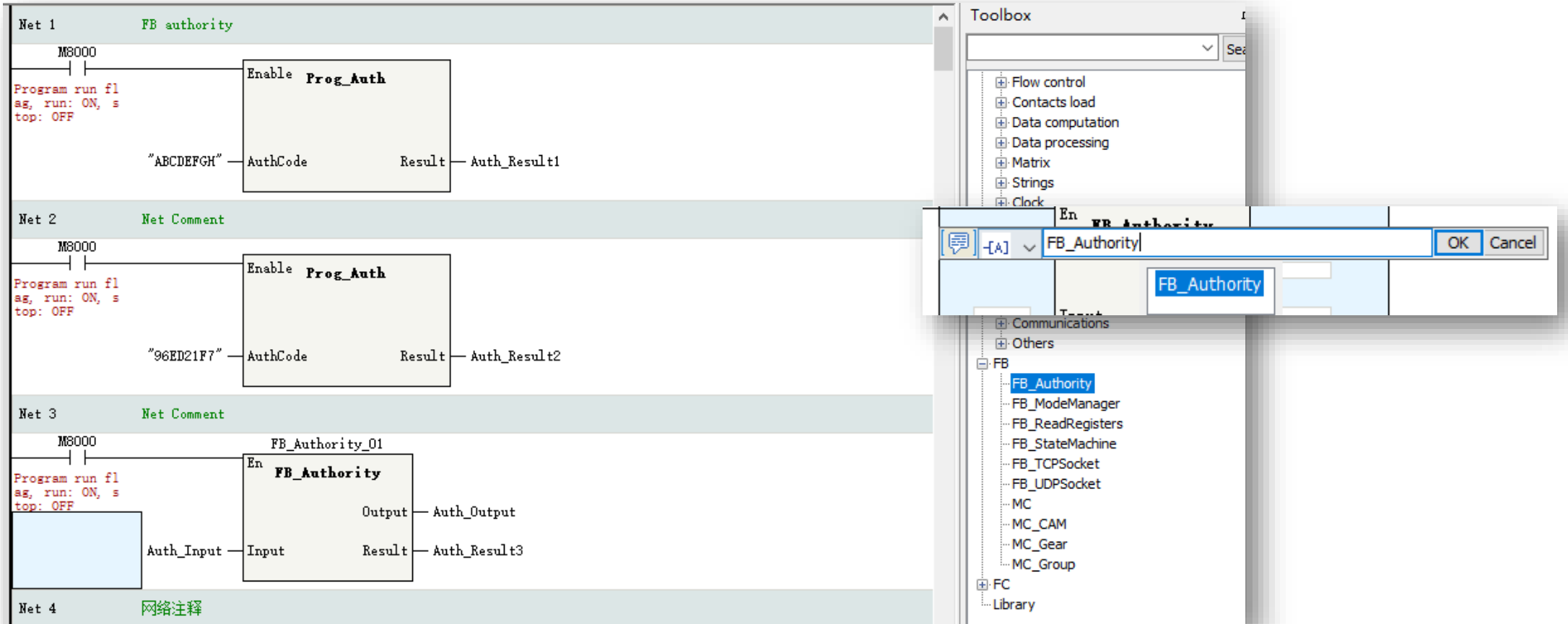

➤ **FB**

4> FB encapsulation

After a FB tested and verified that it works well, users can encapsulate the FB as a library and export, in this way, the FB can be used in another project, improve the development efficiency.

Select the FB and right click to <Export FB>, select the corresponding FBs and export path, user can defined the library version and select if the source code be visible. After click <OK> button, a library file with .fe suffix will generated in specified path.

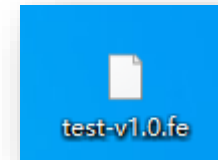
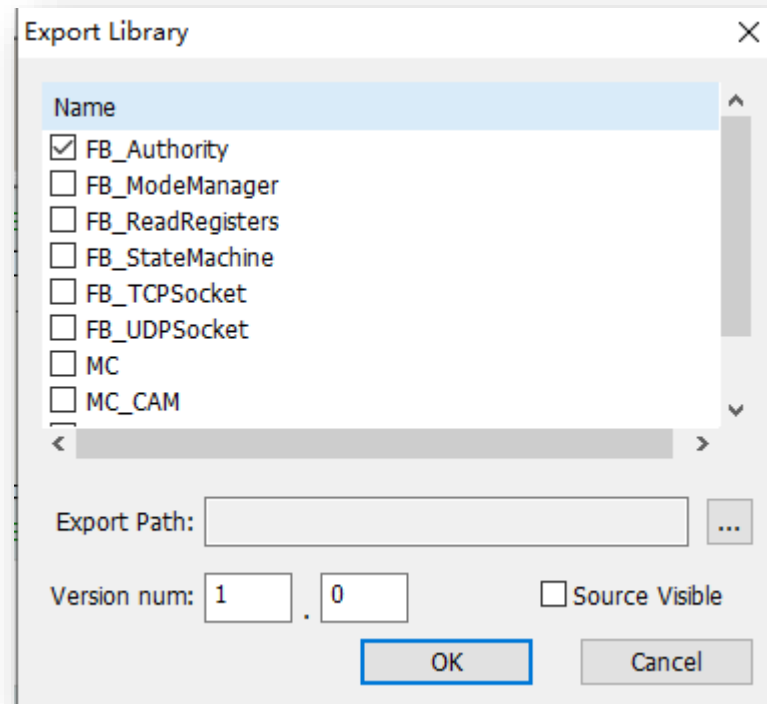
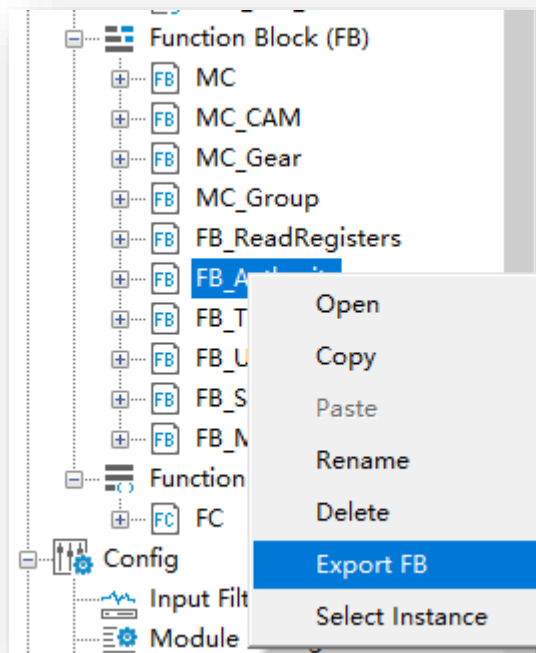

➤ **FB**

4> FB encapsulation

In tool box, select <Library> right click to <Import Library>, select the library file, and then the library will be added in the tool box.

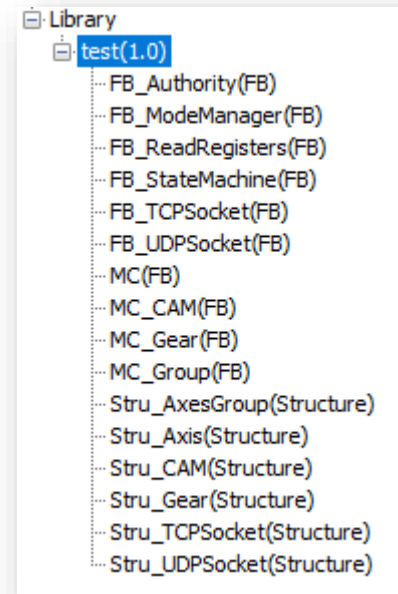
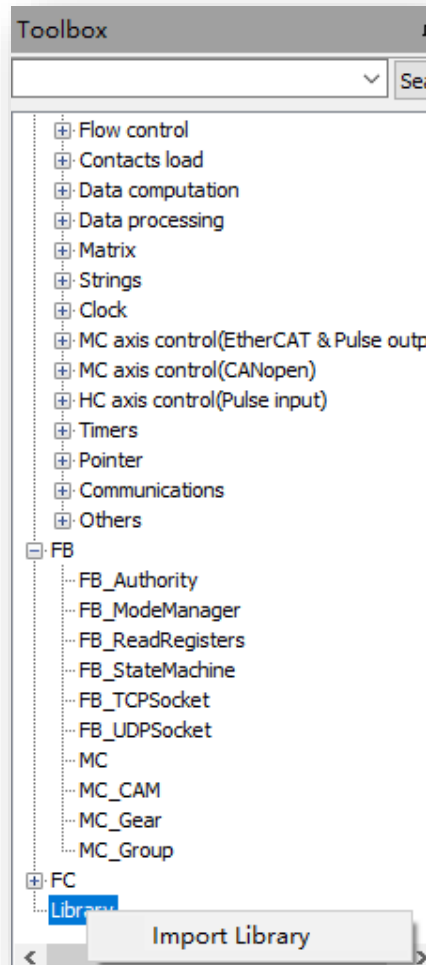

➤ **FB**

4> FB encapsulation

In tool box, select <Library> right click to <Import Library>, select the library file, and then the library will be added in the tool box.

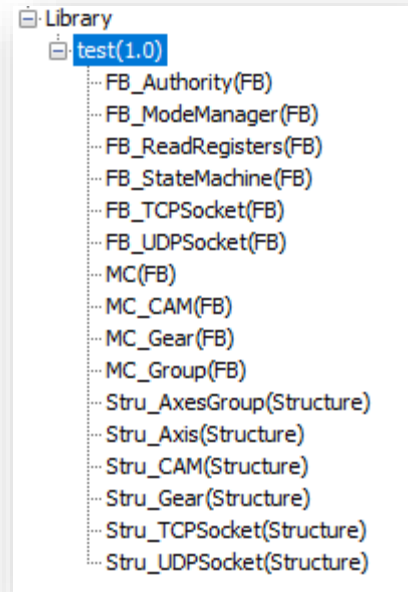
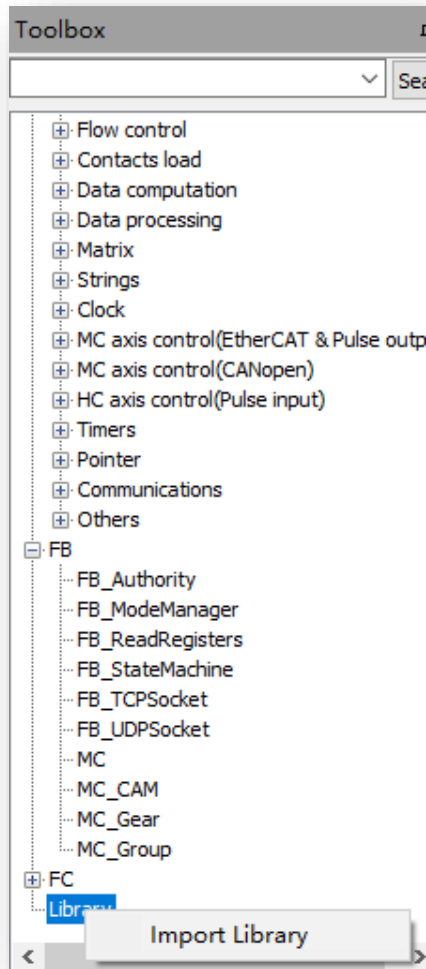

Take note:

There is another way to import library.

In the device tree <Function Block>, right click and select <Import FB>. This way can only import the library with source code visible, and the exported library can only be used in the current project.

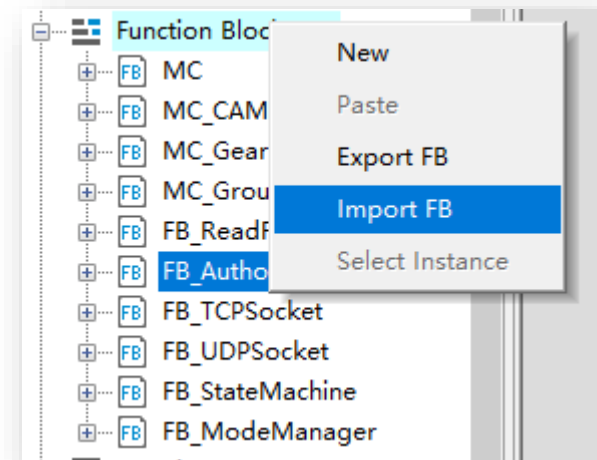

➤ FC

FC is function which used to build specified program as a general program block and can be re-used in program. Using the encapsulated function block, users can save the development time and improve the programming efficiency and quality.

The difference compare with FB:

>FC can only use static internal variable, which means there is no internal memory assigned for these variable and the variable value cannot be stored, in this case, variables in a FC don't support <Retain> property

>For same inputs, the outputs of a FC is a certain value, for example, $\sin\langle x \rangle / \cos\langle x \rangle$ are very common math function, for a certain variable, the output value is certain. MC_MoveAbsolute/MC_MoveRelative are function block, in these block there are internal memory to store the process information, and every time the FB executing, the output value could be update.

The usage of FC show as below:

Create a new FC--<Programming>→<Function> right click and select <New>, then set the function name in the pop up window. Other operation please refer to FB introduction(use in program/export/import)

Take note: Do not use multi cycle instructions or state related instructions(like motion control/LD*) in FC!

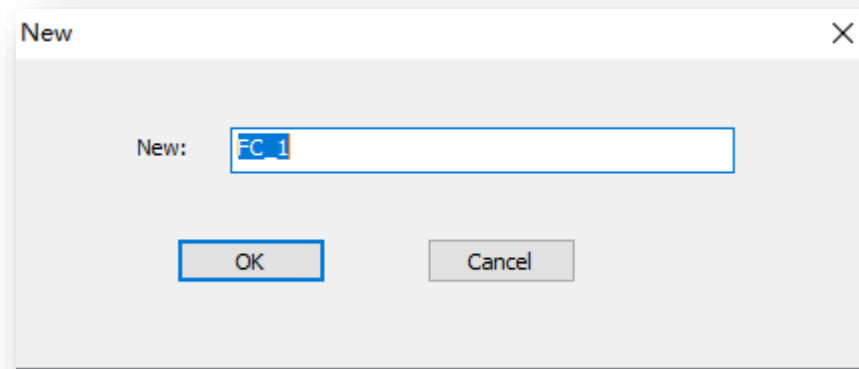
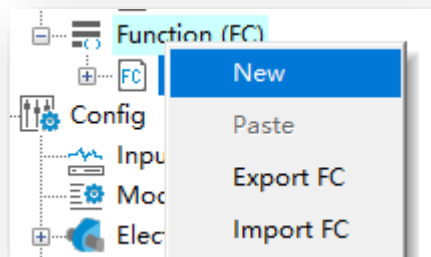

➤ FB Authority

H5U use function Prog_Auth to set function blocks/library authority, only specified controller with authorization can use specified library. In this case, OEM can protect the intellectual property. The authority mechanism working process show as below:

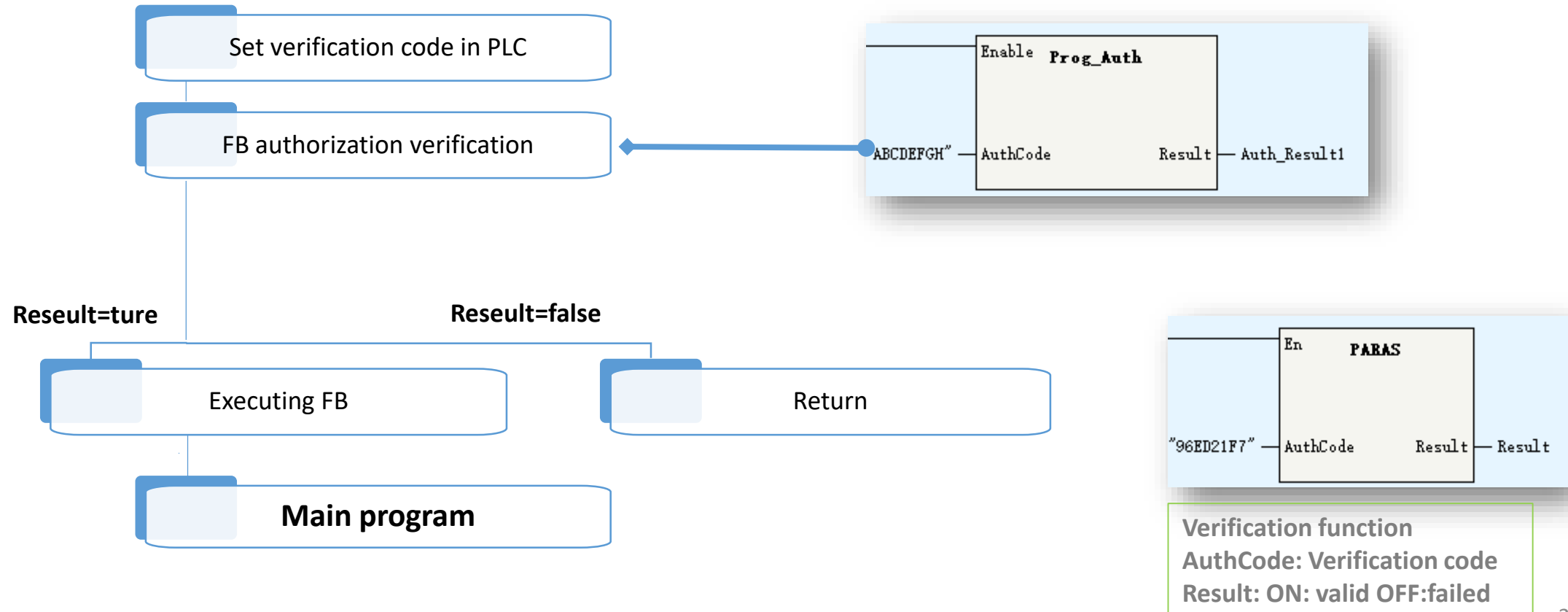

➤ FB Authority

To set the FB authorization, need use a tool called <H5U_AuthManger>, users can find this tool in AutoShop installation directory

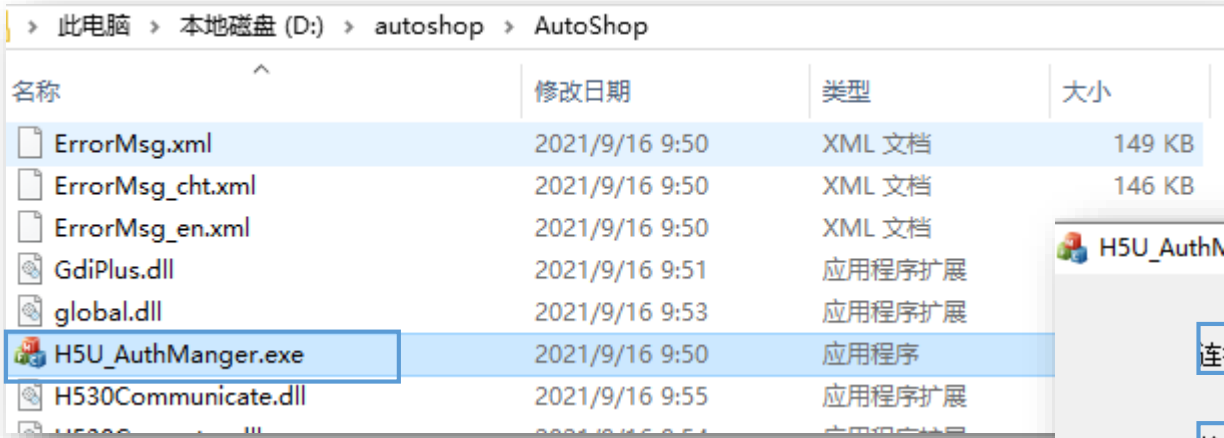

2>Input authorization code, it is a 8 digits numbers set by users

1>Input PLC IP address. Make sure the PLC is connected well with Ethernet cable

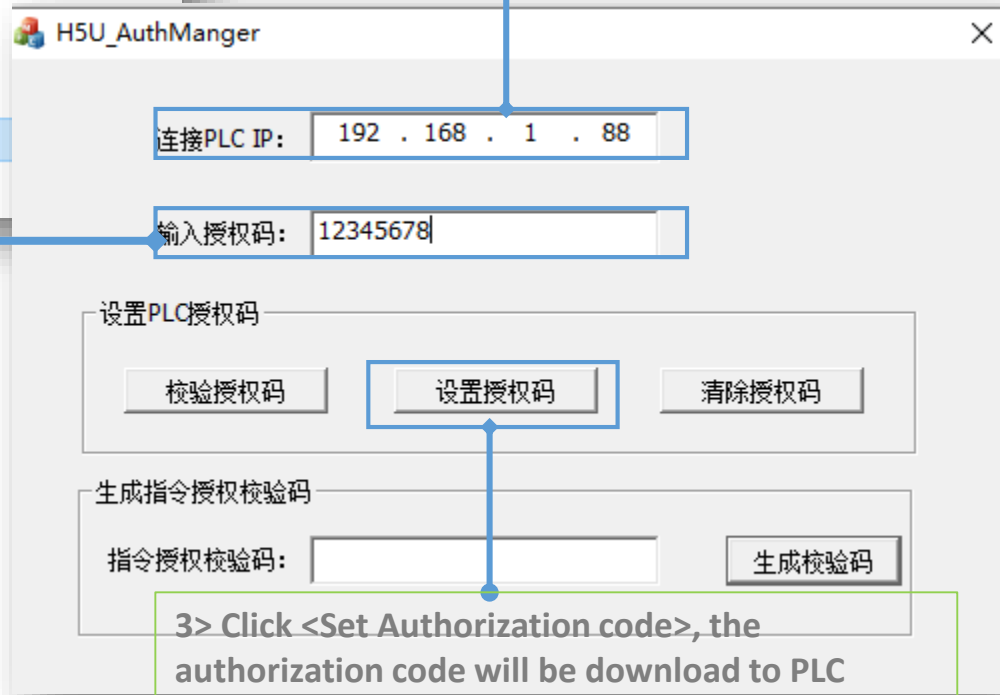

3> Click <Set Authorization code>, the authorization code will be download to PLC

➤ FB Authority

After download the authorization code into controller, users need generate a verification code which will be used in the function block.

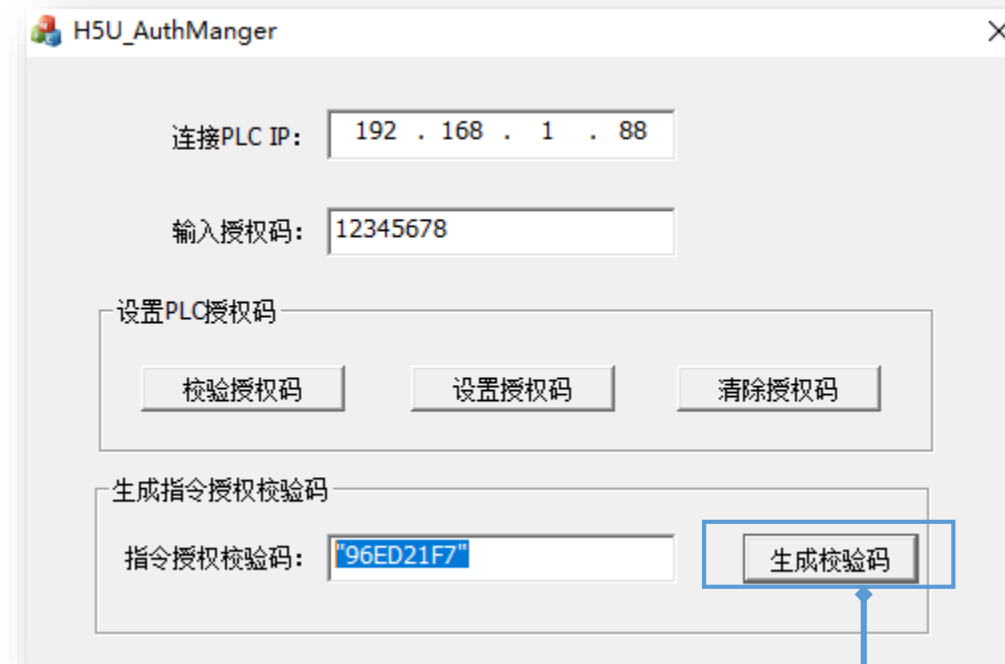

Click <Generate verification code>, then the verification code will be generated, in this case, the verification code is '96ED21F7'.

➤ FB Authority

Open the function block, add the verification function PARAS, the <AuthCode> set as the verification code('96ED21F7').

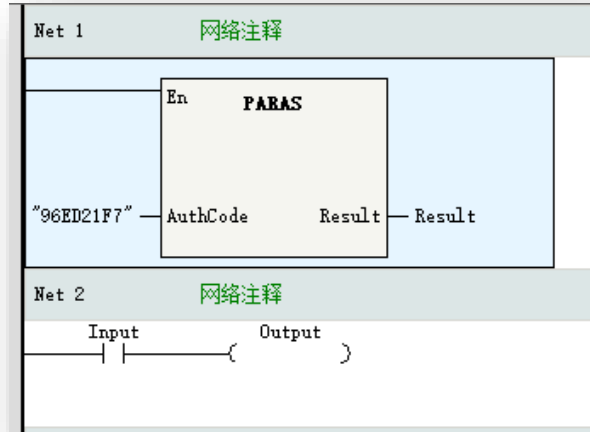

Open the program, add function **PROG_AUTH**. If the verification code not match with the controller, the FB will not execute.

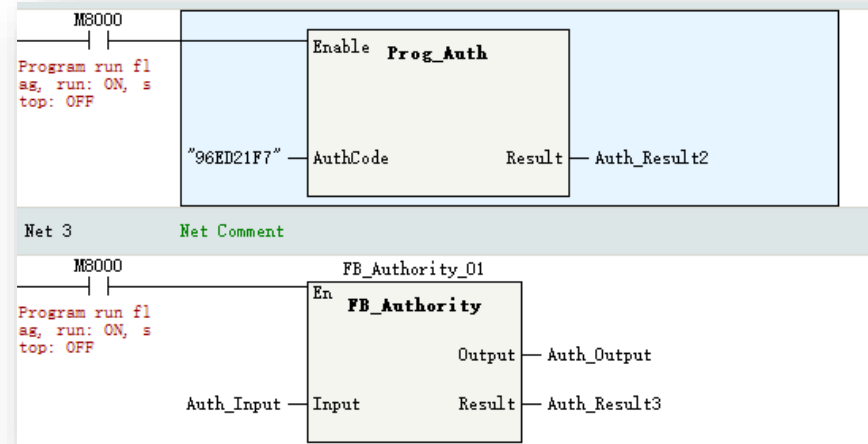

Sub Program

Sub routine category:

Prefix	Meaning	Description
SBR	Common sub routine	Support up to 1024 sub programs, and the sub program can be encrypted.
INT	Interrupt routine	External interruption: X0~X3 input interruption, include rising edge, falling edge and rising/falling edge Timing interruption: 4 channel (time base=1ms) Comparison interruption: 1~16

Sub routine executing mechanism:

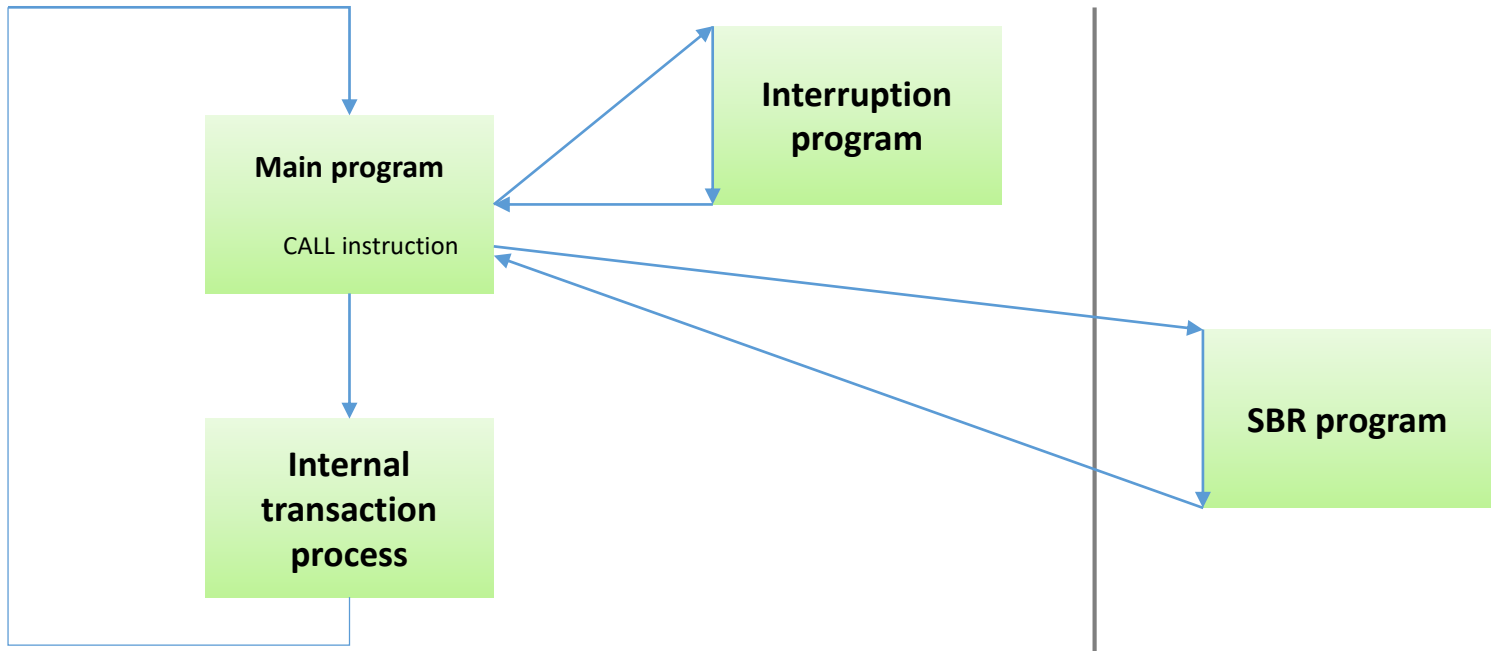

Sub Program

H5U support up to 6 stage sub routine nested. Main program invoke the sub program as the first nested stage, and the invoking in first sub program as the second nested stage, and so on for other nested stages.

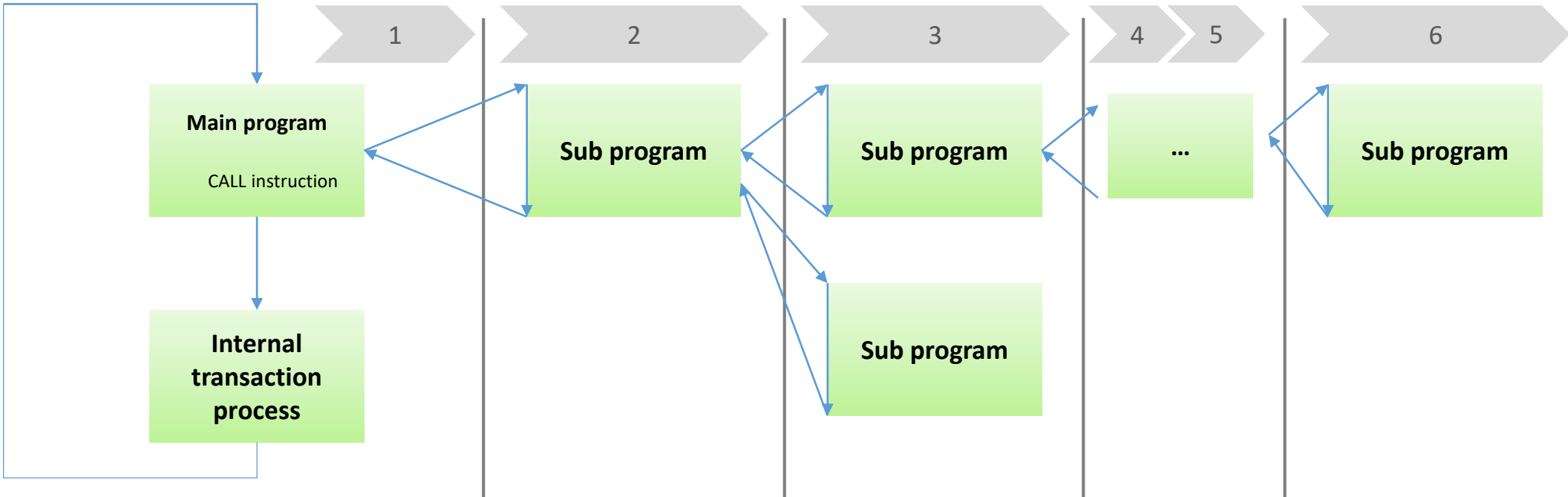

Sub Program

➤ Common Sub Program

In the device tree <Programming>→<Program Block>, right click to <Insert Subprogram>

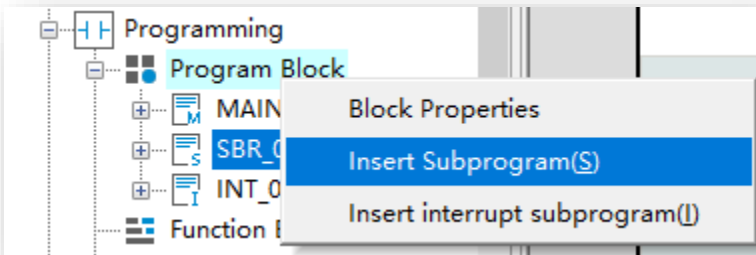

Select the new add sub program, right click <Rename> to modify the program name

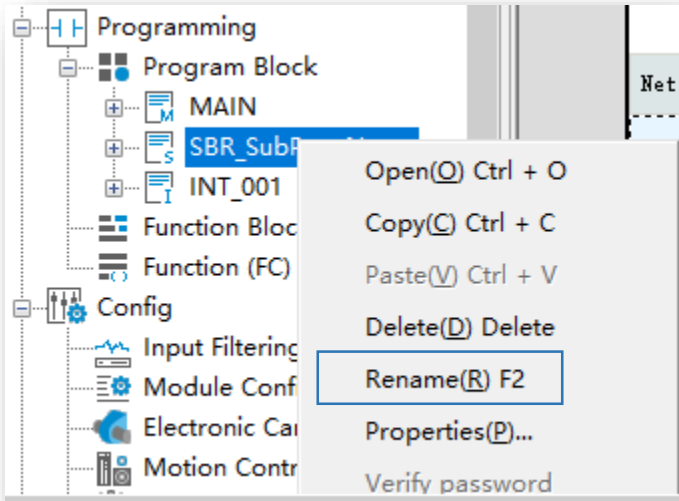

Sub Program

➤ Call Sub Program

Using <Call> instruction to invoke the sub program. Select <Call> in tool box, then the instruction configuration assistant window will pop up, select the corresponding sub program.

The screenshot illustrates the process of adding a subprogram call instruction. On the left, the 'Call Subprogram' configuration window is open, showing a dropdown menu for 'Subprogram Name' with 'SBR_SUBPROGRAMME' selected. A callout box points to this dropdown with the text: "Select the sub program name, then the instruction will be add to program". In the center, the 'Toolbox' window shows the 'CALL(Subroutine call)' instruction selected. On the right, a ladder logic diagram for 'Net 1' shows the 'CALL SBR_SUBPROGRAMME' instruction being added to the network.

Var. Name	Var. Addr.	Var. Type	Data Type	Element	Comment

Sub Program

➤ Encryption Sub Program

To encrypt a sub program, users need to right click to select the <Encryption/Decryption>, then set the sub program password in the pop up setting view.

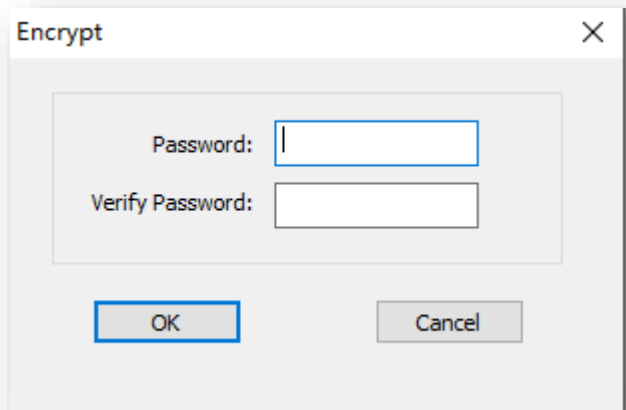
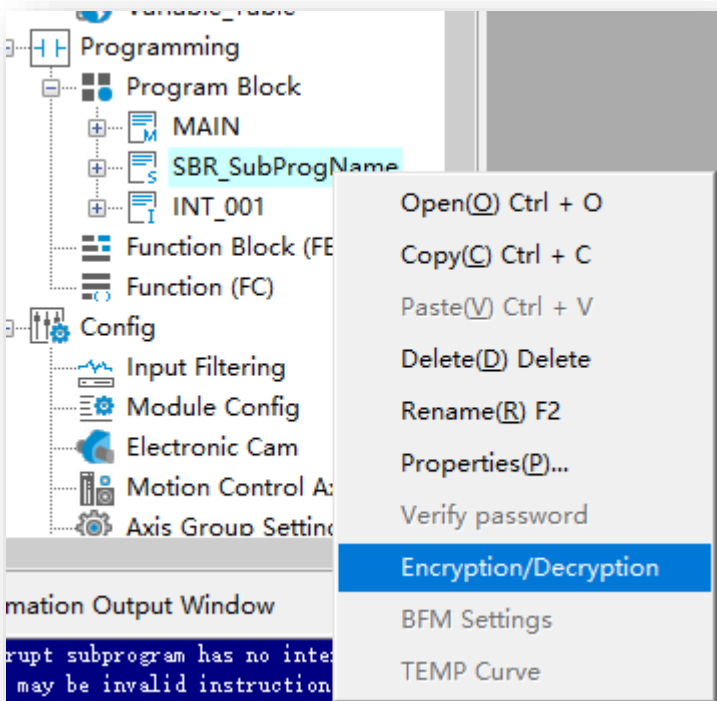

An encryption sub program looks different with non-encrypted program, and it have to enter the password to check the program details.

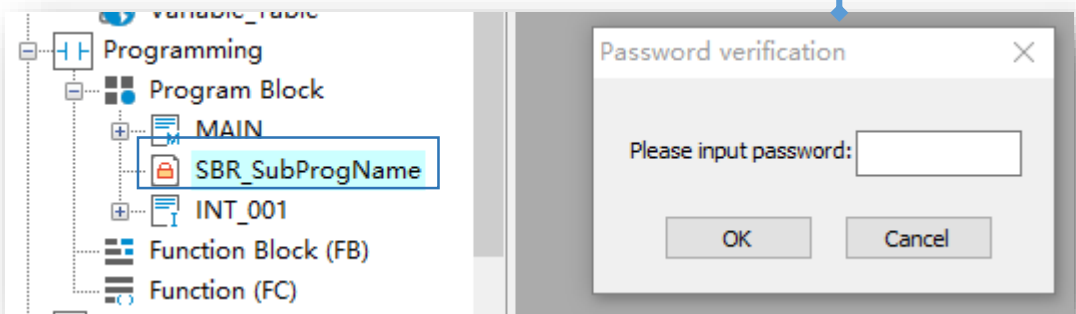

Sub Program

➤ Interruption Sub Program—External interruption

1>In device tree <Programming>→<Program Block>, select <Insert Interrupt subprogram>

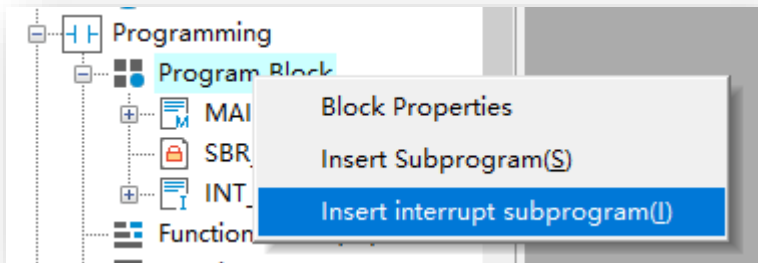

2>Select the interruption sub program, right click <Properties> to open the configuration view

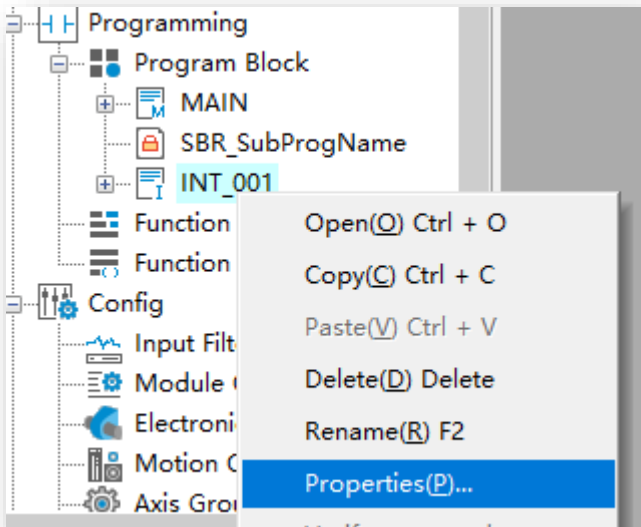

Sub Program

➤ Interruption Sub Program—External interruption

4>Edit program in interruption sub program

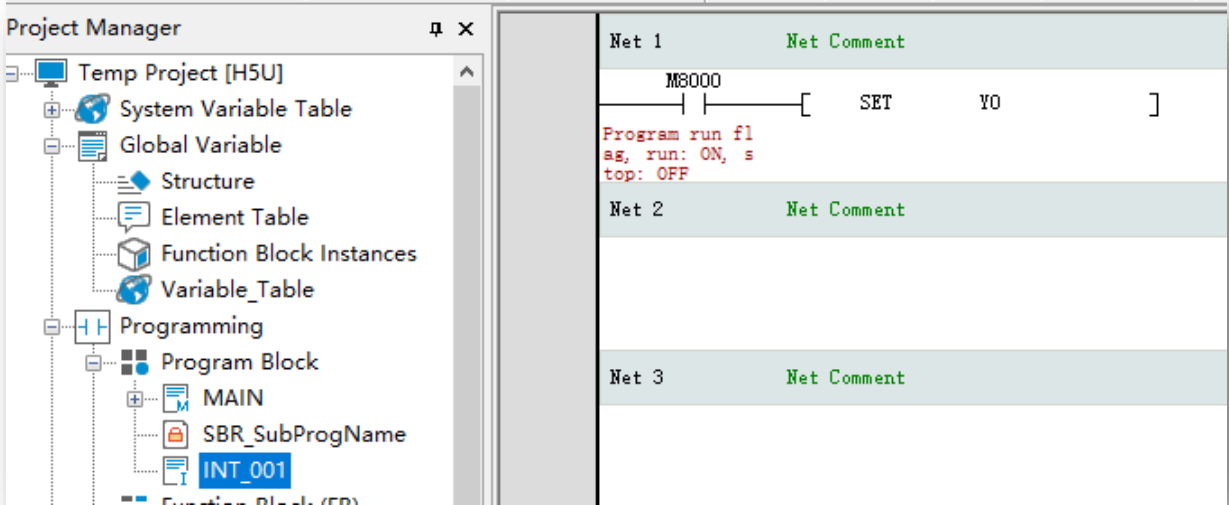

5>Use <EI> command in main program to enable interruption, <DI> to disable interruption

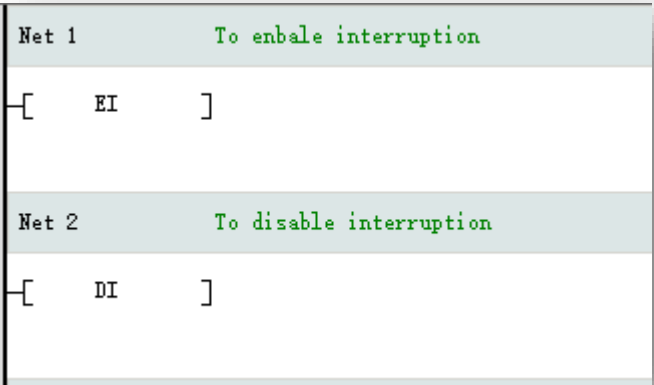

Sub Program

➤ **Interrupt Sub Program—Timing interruption**

Please follow the <External Interruption> configuration steps, the only difference is in Step3, select <Timed interrupt*>, the time base is 1ms, and the range of timing time is 1~1000ms.

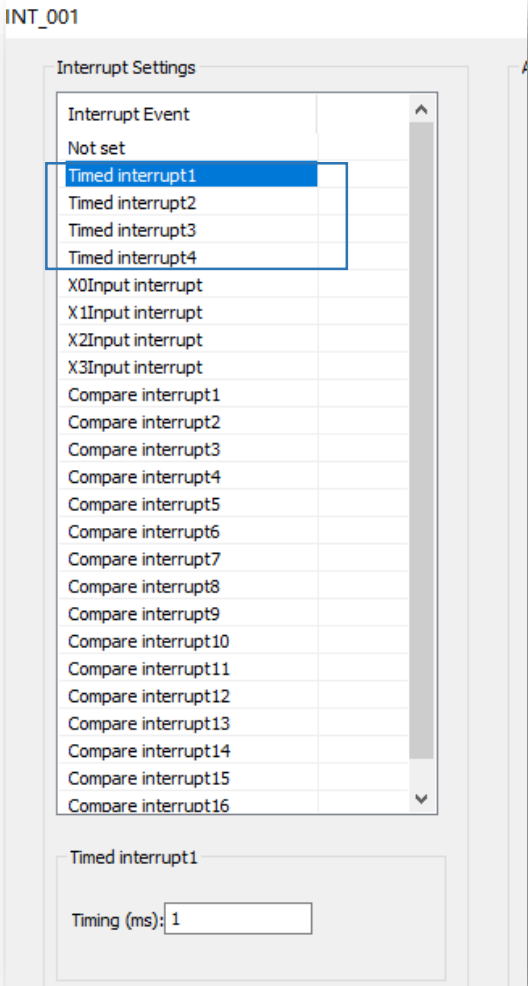

Sub Program

➤ Interruption Sub Program—Comparison interruption

Please follow the <External Interruption> configuration steps, the only difference is in Step3, select <Compare interrupt*>, H5U support up to 16 comparison interruption.

Take note, to use comparison interruption, need using specified function block to set the comparison interruption, please refer the instruction <[High speed inputs](#)>.

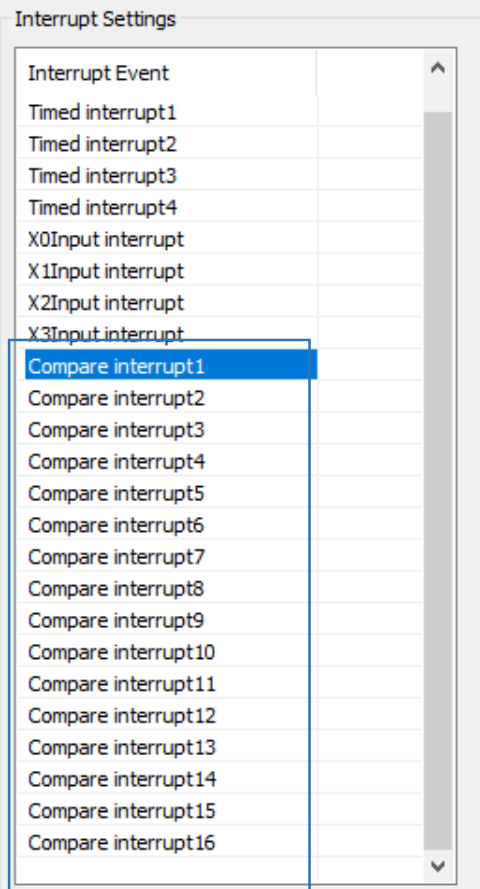

H5U Error Code

H5U Error Code—Program Error

H5U English application manuals are not ready, Users can check the error code of H5U in the IT7000-H5U application example, or check in this document(next slides).

The screenshot displays the INOVANCE H5U Error Code dialog box. The dialog has a blue header with the title "H5U Error Code" and a close button. Below the header, there is a table of error details:

ErrorCode	9502
Prog	
CPU	
IO	
ExtMod	
Canlink	
MIPMaster	
Modbus	
MCAxis	Servo drive disabled
EtherCAT	

Below the table, there is a text box containing the message: "or the error will be occurred when execute the interpolation command." At the bottom of the dialog, there are two buttons: "ErrorCode" and "Close".

The background interface shows a control panel with several buttons: "Enable", "MoveCirc", "MoveLi", "Pause", "Stop", and "Reset". Red arrows point from "Enable" to "MoveCirc" and "MoveLi", and from "Pause" and "Stop" to "Reset". A blue arrow points from "Reset" to the "Reset" button. A status bar at the bottom of the interface shows the message: "err:10001 2021-09-17 09:57:24 xSetMode write error: 10001. 20".

H5U Error Code—Program Error

1500	WatchDog Overtime
1501	Undifiend Command
1502	Un-complete Program
1503	Authority Code Error
1504	Empty Program
1505	POU Error
1510	Sub Routine Error
1511	Sub Routine Type Error
1512	Sub Routine Number Error
1513	Sun Routine Address Error
1514	Interruption Routine Number Error
1515	Interruption Routine Address Error
1516	Interruption Routine Property Error
1517	Interruption Routine Timing Time Error
1520	Program Error
1521	Program Type Error
1522	Program Number Error
1523	Program Address Error
1524	Program Variable Quantity Error
1525	Program Variable Length Error
1526	Program Head Data Error
1530	CJ-LBL Label Number Error

1531	CJ-LBL Label address Error
5001	Program Abnormal, part of commands not executed
5010	CALL Command Error: Sub routine number error
5011	CALL Command Error: Sub routine not exist
5012	CALL command Error: Sub routine program nested over range
5013	CALL Command Error: Sub routine return error
5014	Sub Routine invoking and Return Not Match
5015	Interruption program not define
5016	Interuption program interruption quenes overflow
5020	FB/FC Program Number Error
5021	FB/FC Program Not Exist
5022	FB/FC Variable Not Exist
5023	FB/FC nested over range
5024	FB/FC Return Error
5025	Program invoke and return not match
5030	CJ-LBL command LBL Number Error
5031	CJ-LBL command LBL Not Exsit
5032	FOR/NEXT nested over range
5033	FOR/NEXT loop times over RANGE
5034	FOR/NEXT loop times equal to 0
5035	FOR/NEXT not match
5101	Command Parameters Address Error
5102	Command Parameters Over Range
5103	xxxx0001 Error
5104	Command Parameters Order Error
5105	String Command: String Error or Length Error
5110	Pointer Number Error

H5U Error Code—Program Error

5111	Pointer Not Initiate
5112	Pointer point to Empty or over Range
5113	Pointer offset value over range
5114	Pointer point to Empty or over range after calculation
5120	Counter failed to instantiate
5121	Counter Command Comparison value error
5130	Timer failed to instantiate
5131	Timer Command Comparison value error
5140	SFC/STL branch over range
5150	FB command failed to instantiate
5160	Array Index Error: encoder error or not exist
5161	Array index Error: Over range
5600	SerialSR command failed to instantiate
5601	SerialSR command port number error
5602	SerialSR command protocol error
5603	SerialSR command port conflict
5604	SerialSR send data over range
5605	SerialSR send data buffer abnormal
5606	SerialSR receive data over range
5607	SerialSR receive data buffer abnormal
6580	CANopen Axis Command: Invalid Axis No.
6701	Invalid Memory Address
6705	Invalid Memory Size
6706	Data Error: Unreasonable or over range
6711	Invalid variable address
6712	invalid variable size
6713	invalid variable coding

H5U Error Code—CPU

1011	FPGA initial failed
1012	Interruption initial failed
1013	Timing Interruption initial failed
5200	Non-volatile data error
5238	Alarm: 2038 is coming
5250	RTC not stable
5900	Ethernet IP address conflict

H5U Error Code—IO

5300	Initial failed
5301	invalid input filter

H5U Error Code—IO

5400	Hardware initial failed
5401	Config data analysis failed
5402	ExtMod slot initial failed
5403	ExtMod Not Found
5404	ExtMod and Config Not Match
5405	ExtMod Hardware Interface Abnormal
5406	ExtMod Software Interface Abnormal
5411	ExtMod No Power Supply
5412	ExtMod Hardware Fault
5413	ExtMod Temperature is too high
5419	ExtMod Input/Output Overflow(up)
5420	ExtMod Input/Output Overflow(low)
5421	ExtMod Input over up limit or output no connection
5422	ExtMod Input over lower limit or output short circuit
5423	ExtMod Input no connection or Output hardware fault

H5U Error Code—CANlink

6300	Input device not assigned to Axis
6301	Axis scaling parameters error
6302	Software limit or rotary parameters invalid
6303	Invalid Axis Counter Mode or Input signal type
6304	invalid input for axis preset func
6305	Invalid input for touch probe 1
6306	Invalid input for touch probe 2
6307	invalid output for comparison output
6308	Invalid pulse width for comparison output
6400	Slave address conflict
6401	Slave offline
6411	Slave abnormal 1: undefined device code
6412	slave abnormal 2: PDO number over range
6413	slave abnormal 3: invalid register address
6415	slave abnormal 5: invalid register length
6416	slave feedback timeout
6421	slave sync abnormal 1: invalid command code
6422	slave sync abnormal 2: invalid register address
6423	slave sync abnormal 3: data over range
6424	slave sync abnormal 4: invalid operation under current status
6425	slave sync abnormal 5: invalid data length
6426	slave feedback timeout while sync

H5U Error Code—Modbus

[Back to Contents](#)

5500	Modbus-RTU data length have to be 8 bit
6001	Abnormal(01):invalid function code
6002	Abnormal(02):invalid data address
6003	Abnormal(03):invalid data value
6004	Abnormal(04):slave device fault
6128	different station No. between request and response frame
6129	different functoin code between request and response
6130	different data address between request and response
6131	different data value between request and response
6240	invalid map address
6255	request timeout

H5U Error Code—Modbus TCP Master

6000	No Connection
6001	Abnormal(01):invalid function code
6002	Abnormal(02):invalid data address
6003	Abnormal(03):invalid data value
6004	Abnormal(04):slave device fault
6128	different station No. between request and response frame
6129	different function code between request and response
6130	different data address between request and response
6131	different data value between request and response
6240	invalid map address
6255	request timeout

H5U Error Code—Motion Control Axis

9001	Local Axis Estop valid
9003	Over speed(pulse output over 200kHz)
9020	Homing Error: N-limit not mapped
9021	Homing Error: P-limit not mapped
9022	Homing Error: Origin not mapped
9023	Homing Error: pulse output over 200kHz
9024	Homing Error: timeout
9025	Homing Error: limit signal error
9030	Limit Valid
9031	sync error: target output pulse not match with actual output pulse
9101	Axis Type error or not exist
9102	axis config failed
9103	invoke MC_Reset when axis no error
9104	axis in unknow statuswhen invoking MC_ReadStatus
9105	Invoking MC_SetPosition while axis running
9106	Axis in fault stopping
9107	Unreasonable Parameters
9108	Unreasonable PLCopen state machine
9110	re-invoke MC_Stop
9111	Command linked list lost
9112	Axis No. Change
9113	MC_Reset Timeout
9114	0x6060 write failure
9115	Invoke MC_Halt when stopping
9116	Axis in online debug mode
9117	Command functionality not available
9118	Command acc/dec over range
9119	MC_Jog target velocity over range
9120	target velocity over range
9121	Jog command P/N signals valid at same tiem

9122	EtherCAT axis without control word mapping
9123	EtherCAT axis without target position mapping
9124	EtherCAT axis without target torque mapping
9125	EtherCAT axis without status word mapping
9126	EtherCAT axis without actual position mapping
9127	EtherCAT axis without 0x60FD mapping
9128	EtherCAT axis without actual torque mapping
9129	EtherCAT axis without TP control word mapping
9130	EtherCAT axis without TP status word mapping
9131	EtherCAT axis without TP position mapping
9132	MC_MoveFeed occupied the probe channel
9133	Axis in virtual mode
9134	Virtual axis TP is on use
9135	No interruption detected while MC_MoveFeed done
9136	TP channel occupied while MC_MoveFeed on use
9137	Filed bus drive without 0x6060 mapping
9138	Filedbus drive without 0x6061 mapping
9139	Re-invoke MC_Home while homing
9140	Command target torque over limit
9141	Filed bus drive without max vel mapping
9142	Estop valid
9143	Re-invoke Estop Command
9144	Limit valid when jogging
9145	Target position over 9999999
9146	Target velocity over 9999999
9147	Target acceleration over 9999999
9148	Target deceleration over 9999999
9149	Axis in SYNC motion status
9150	MC_Halt valid
9151	MC_MoveVelocityCSV pulse width over range

H5U Error Code—Motion Control Axis

9152	CSV mode without 0x60FF mapping
9153	TP terminal not configure
9200	Failed to get CAM configuration file
9201	Failed to get master axis
9202	Failed to get slave axis
9203	failed to get CAM table
9204	CAM quantities over range
9205	CAM key points not found
9206	Modify master axis while in CAM
9207	MC_CamIn StartMode over range
9208	MC_CamIn StartPosition over range
9209	MC_CamIn MasterStartDistance over range
9210	MC_CamIn MasterScaling over range
9211	MC_CamIn SlaveScaling over range
9212	MC_CamIn MasterOffset over range
9213	MC_CamIn SlaveOffset over range
9214	MC_CamIn MasterScaling is non-positive number
9215	MC_CamIn SlaveScaling is non-positive number
9216	MC_CamIn/MC_GearIn ReferenceType over range
9217	MC_CamIn Direction over range
9218	MC_CamIn BufferMode over range
9219	CAM table master position not in ascending order
9220	CAM table curve type over range
9221	MC_CamOut target deceleration over 9999999
9222	MC_CamOut target deceleration over range
9223	MC_Phasing target acceleration over 9999999
9224	MC_Phasing target acceleration over range
9225	MC_Phasing target velocity over 9999999
9226	MC_Phasing target velocity over range
9227	MC_CamOut curve type over range

9228	MC_CamOut mode over range
9229	MC_GenerateCamTable:CAM points array is empty
9230	MC_GenerateCamTable:CAM points over limit
9231	MC_GenerateCamTable:Mode over range
9232	MC_GenerateCamTable: Nodes less than 2
9233	MC_GearIn RatioNumberator equal to 0
9234	MC_GearIn RatioDenominator is non-positive number
9235	Invoke MC_SaveCamTable while MC_GenerateCamTable on use
9236	Invoke MC_GenerateCamTable while MC_SaveCamTable on use
9237	Failed to open CAM file while executing MC_SaveCamTable
9238	Failed to write points number while executing MC_SaveCamTable
9239	Failed to write data while executing MC_SaveCamTable
9240	First master position is not 0
9241	First slave position is not 0
9242	MC_GearOut Mode over range
9243	MC_Phasing deceleration over 9999999
9244	MC_GearIn deceleration over 9999999
9245	MC_CamIn Periodic over range
9246	CAM master position over 9999999
9247	CAM slave position over 9999999
9248	CAM speed over 9999999
9249	Gear Points is empty
9250	Master and slave map to same axis
9251	Master address greater than slave address
9252	Master fFilter[0] over range
9253	Master fFilter[1] over range
9254	Master fFilter[2] over range
9255	Sum of Master filter coefficients is not equal to 1
	MC_CamIn: unreasonable StarPosition and
9256	MasterStartPosition(positive direction)

H5U Error Code—Motion Control Axis

9257	MC_CamIn: unreasonable StarPosition and MasterStartPosition(negative direction)
9258	MC_GearOut deceleration over 9999999
9259	MC_Phasing deceleration over range
9260	MC_GearIn deceleration over range
9261	MC_GearOut deceleration over range
9262	MC_GearIn acceleration over 9999999
9263	MC_GearIn acceleration over range
9264	MC_Phasing curve type over range
9265	MC_GearIn curve type over range
9266	MC_GearOut curve type over range
9267	Modify slave while in CAM
9268	MC_Phasing PhasingMode over range
9269	Axis not in CAM while invoking MC_CamOut
9270	Axis not in GEAR while invoking MC_GearOut
9271	Too much master position change in CAM/GEAR(1 EtherCAT cycle)
9272	MC_GetCamTableDistance Phase over range
9273	Modify slave while invoking MC_GearIn
9400	Axis number over limit(Axes up to 4)
9401	Axis in axes group in error status
9402	Buffer ITP commands over 8
9403	Axis reused in Aexs groups
9404	Lack of X/Y axis in Axes group
9405	Z axis not exist in axes group
9406	Axes group: auxiliary axis not exist
9407	Axes group: axes group ID reuse
9408	Axes group: failed to configure axis
9409	Axes group: ID less than 0
9410	Axes group not released
9411	MC_GroupStop aborted

9412	MC_MoveCircular: CircAxes over range
9413	MC_MoveCircular: CircMode over range
9414	MC_MoveCircular: PatchChoice over range
9415	MC_GroupStop: StopMode over range
9416	Axes group: X axis is in rotation mode
9417	Axes group: Y axis is in rotation mode
9418	Axes group: Z axis is in rotation mode
9419	Axes group: A axis is in rotation mode
9420	Re-trigger MC_MoveCircular
9421	Re-trigger MC_MoveLinear
9422	Failed to get axes group
9423	Axes group: failed to configure axis
9424	Axes group: axis in axes group not enabled
9425	Axes group: axis in axes group in single motion status
9426	Axes group: axis in axes group in stopping status
9427	Axes group in stopping status
9428	Axes group: axis in axes group in homing status
9429	Axes group: axis in axes group executing MC_SetPosition
9430	Axes group: axis in axes group in debug mode
9431	Axes group: axis in axes group get into debug mode while ITPing
9432	Axes group: Failed to get memory
9433	Axes group: Target Velocity is 0
9434	Axes group: Target acceleration is(or less then) 0
9435	Axes group: Target deceleration is(or less then) 0
9436	Axes group: CurveType over range
9437	Axes group: Unreasonable AbsRelMode
9438	Axes group: Unreasonable BufferMode
9439	Axes group: Unreasonable InsertMode
9440	Axes group: Axis in axes group in fault
9441	Axes group: re-invoke MC_GroupStop

H5U Error Code—Motion Control Axis

9442	Axes group: Data Buffer is not empty
9443	Axes group: Cannot form an arc
9444	Axes group: Cannot form a circle
9445	Axes group: Command buffer is full
9446	Axes group: X axis speed over range
9447	Axes group: Y axis speed over range
9448	Axes group: Z axis speed over range
9449	Axes group: A axis speed over range
9450	Failed to get axes quantities
9451	Internal fault
9452	Cannot invoke this command in StandStill Status
9453	Speed over range
9454	ACC/DEC over range
9455	MC_MoveLinear error
9456	MC_MoveCircular error
9457	MC_GroupStop error
9458	MC_GroupPause error
9459	X axis is running in other group
9460	Y axis is running in other group
9461	Z axis is running in other group
9462	A axis is running in other group
9463	MC_GroupStop:axis in axes group in other sync motion(CAM or ITP)
9464	MC_MoveLinear/Circular:axis in axes group in other sync motion(CAM or ITP)
9465	MC_GroupPause:axis in axes group in other sync motion(CAM or ITP)
9501	EtherCAT servo error
9502	Servo drive disabled
9503	Limit valid
9505	Failed to modify control mode
9508	failed to homing

9509	Axis internal calculation error
9510	Following error over range
9512	Servo disconnected during running
9513	Failed to homing caused by servo fault
9514	Failed to homing caused by offset over range
9515	Failed to homing caused by slave lost
9516	Failed to homing caused by SDO writing failure(0x607C)
9517	Failed to homing caused by SDO writing failure(0x6060)
9518	Failed to homing caused by SDO reading failure(0x6061)
9519	Failed to homing caused by SDO writing failure(0x6060=8)
9551	Failed to exchange control mode
9552	Target velocity is 0
9601	MC_MoveAbsolute pars abnormal
9602	MC_MoveRelative pars abnormal
9603	MC_MoveVelocity pars abnormal
9604	MC_Jog pars abnormal
9605	MC_MoveVelocityCSV pars abnormal
9606	MC_MoveBuffer pars abnormal
9607	MC_MoveFeed pars abnormal
9608	MC_Stop pars abnormal
9609	MC_MoveTorque pars abnormal
9610	MC_Halt pars abnormal
9611	MC_MoveSuperImposed pars abnormal
9612	MC_SyncMoveVelocity pars abnormal
9613	MC_SyncTorqueControl pars abnormal
9701	Failed to apply memory for encoder axis
9702	Invalid encoder axis type
9703	Axis config failure
9704	No config for 'Counter operation command' of encoder axis IO mapping
9705	No config for 'Counter status' of encoder axis IO mapping

H5U Error Code—Motion Control Axis

9706	No config for 'Encoder present position' of encoder axis IO mapping
9707	No config for 'Pulse rate' of encoder axis IO mapping
9708	Encoder axis: pos limit not greater than neg limit
9709	Encoder axis: pos limit over 2147483647(pulse unit)
9710	Encoder axis: neg limit below -2147483647(pulse unit)
9711	Encoder axis: rotation mode cycle over 2147483647(pulse unit)
9712	ENC_Counter: exchange axis mapping while command valid
9713	GR10-2HCE fault
9714	Encoder axis: failed to reset fault
9715	invoke ENC_Reset while there is no encoder axis error
9716	ENC_Preset: TriggerMode over range
9717	ENC_Preset: position over 9999999
9718	No config for 'Physical output command' of encoder axis IO mapping
9719	Encoder axis:Preset value or comparison output value over pos limit
9720	Encoder axis:Preset value or comparison output value below neg limit
9721	Encoder axis:Preset value or comparison output value over 2147482647 or below -2147483638(pulse unit)
9722	Encoder axis:Preset value or comparison output value over(or same as) cycle value(rotation mode)
9723	ENC_TouchProbe: ProbelD over range
9724	ENC_TouchProbe: TriggerEdge over range
9725	ENC_TouchProbe: TerminalSource over range
9726	ENC_TouchProbe: TriggerMode over range
9727	No config for probe statusword of encoder axis IO mapping
9728	No config for probe position feedback of encoder axis IO mapping
9729	No config for control word of encoder axis IO mapping
9730	Encoder axis: probe window first position greater(or equal to) than last position
9731	Xn0 not config as touch probe

9732	Xn1 not config as touchprobe
9742	No config for 'Compared mode' of encoder axis IO mapping
9743	No config for 'Compared pulse/time' of encoder axis IO mapping
9744	No config for 'Compared size/step' of encoder axis IO mapping
9745	No config for 'Compared point value 1' of encoder axis IO mapping
9746	No config for 'Compared point value 2' of encoder axis IO mapping
9747	No config for 'Physical output status' of encoder axis IO mapping
9748	No config for 'Compare error code' of encoder axis IO mapping
9749	No config for 'Current compare number/position' of encoder axis IO mapping
9750	Single axis array comparison command failed to get array address
9751	Axes array comparison command failed to get array address
9752	Fieldbus encoder axis not map to a slave
9753	Axes array comparison command not map to same slave
9754	Axes array comparison command X axis not map to ch0 of slave
9755	Axes array comparison command Y axis not map to ch1 of slave
9756	Yn0 not config as comparison output
9757	ENC_StepCompare:StartPosition over 9999999
9758	ENC_StepCompare:EndPosition over 9999999
9759	ENC_StepCompare:abs value of Step over 9999999
9760	Encoder comparison output command 'Parameter' over 9999999
9761	Encoder comparison output command 'Mode' over 9999999
9762	Encoder comparison output command time over range(time mode)
9763	ENC_StepCompare: Step is 0
9764	ENC_StepCompare: StartPosition is same as EndPosition
9765	ENC_StepCompare: Step is negative value while StartPosition < EndPosition
9766	ENC_StepCompare: Step is positive value while StartPosition > EndPosition
9767	ENC_ArrayCompare: Size over range

H5U Error Code—Motion Control Axis

9768	ENC_ArrayCompare:target position over 9999999
9769	Current axis is on single comparison process cannot aborted by array comparison command
9770	EtherCAT slave offline
9771	Fieldbus encoder axis is in offline debug mode
9772	Digital input not config as preset position functionality
9773	Comparasion commands: Parameter over range(pulse mode)
9774	2HCE model fault while invoke comparison commands
9775	Set position below 0 while in rotation mode
9776	Y00 not config as array comparison output
9777	Current axis is on array comparison process cannot aborted by single comparison command
9800	Cannot read the quantities of axes
9801	Axes quantities over range
9802	Axis internal memery assigned failure
9803	Axis failed to get parameters
9804	Failed to get slave

H5U Error Code—EtherCAT

8001	Failed to read master info
8002	Failed to read slave info
8003	EtherCAT start timeout
8004	Failed to apply master
8200	Failed to write SDO to slave
8201	Slave lost while fieldbus running
8202	Slave switch to non operational mode
8203	Slave state machine switch failure
8204	Slave type not match
8205	PDO address error
8206	PDO length error
8301	Failed to switch to INIT state
8302	Failed to switch to PreOP state
8304	Failed to switch to SafeOP state
8308	Failed to switch to OP state
8310	FMMU unit config error
8311	Mailbox config error
8400	ECTA config error
8401	ECTA hardware error
8402	ECTA extension module error

H5U Application Example

Application Example

[Back to Contents](#)



Backup20211102.7z

INOVANCE

Forward Always Progressing