

AM600 Series

PLC Hardware Manual



Introduction

Thank you for purchasing the AM600 series programmable logic controller (PLC) and its expansion modules developed and manufactured by Inovance.

Before using the product, read this guide and the related documents mentioned in this guide. Exercise safety cautions when performing operations.

Note

- ◆ To show details, some of the figures in this document show the product with the cover or housing removed. When using this product, ensure that the cover or housing is installed and perform operations according to the guide.
- ◆ The figures in this document are for reference and may be different from the actual product.
- ◆ Inovance is committed to continuous improvement of products. Product functions will be upgraded, and the documents provided are subject to change without notice. You can download the latest documents from www.inovance.cn.
- ◆ If you have any problems in using the product, please contact the local dealer or contact the customer service center of Inovance. Customer service: 400-777-1260, email address: UM@inovance.com

Related Documents

The documents related to this PLC are listed below. Use them as required:

- AM600 Series PLC Hardware Manual (this document)
- AM600-CPU1608TP CPU Module User Guide, data code: 19010638
- AM610-CPU1608TP CPU Module User Guide, data code: 19010675
- AM610 Series PLC Programming Manual - Motion Control (coming soon)

Product Features

The AM600 has the following features:

- 1) Supports the IEC61131-3 programming environment, complies with the PLCopen regulations, and provides the multi-axis motion control functions such as PLC logic control, SoftMotion, and CNC.
- 2) Provides 16 input and 8 output built-in HSIO ports and supports 8 AB-phase high-speed counters and 4 groups of pulse positioning.
- 3) Supports different fieldbuses, including EtherCAT, CANopen, and PROFIBUS-DP.
- 4) Supports more I/O channels through the EtherCAT bus extended rack.
- 5) Provides larger program storage capacity (4 MB) and data store (8 MB).
- 6) Supports faster command execution (4 ns).
- 7) Supports more advanced fieldbuses such as PROFIBUS-DP, EtherCAT, and CANopen.
- 8) Provides more easy-to-use software adapted to domestic users' operation habits.
- 9) Supports the online error detection mode and offline emulated debugging.
- 10) Supports online editing and download of user programs.

EMC Reference Compliance

The AM600 series modules comply with the European EMC directive 2014/30/EU and meet the requirements in the EN 61131-2: 2007 standard.

Basic System Startup Process

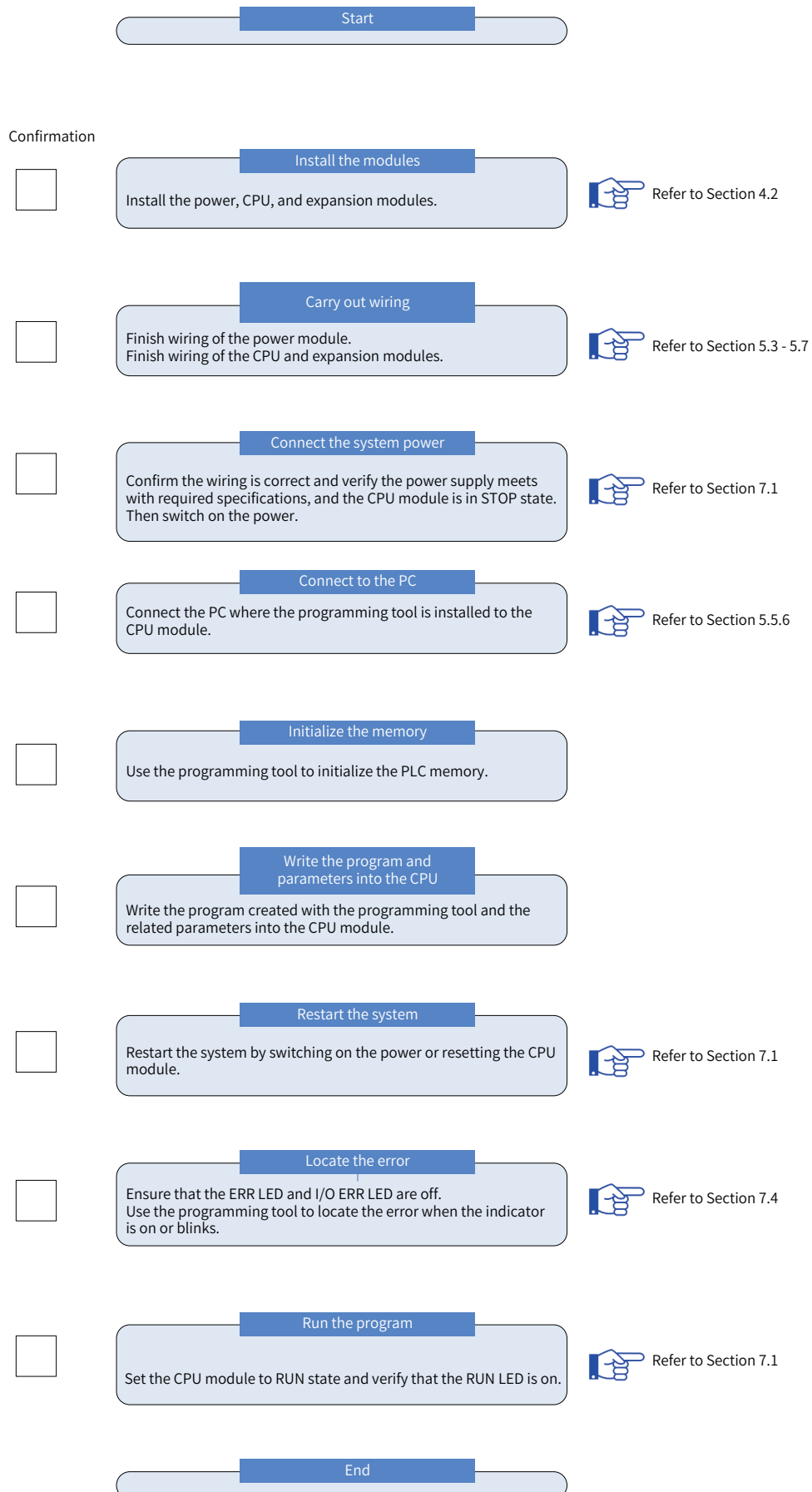

Contents

Introduction	1
Related Documents.....	1
Product Features	1
EMC Reference Compliance.....	1
Basic System Startup Process	2
Chapter 1 Safety Instructions.....	7
Before You Start.....	8
Safety Instructions	8
Chapter 2 Product Information.....	11
2.1 Product System Assembly.....	12
2.1.1 Functions of the CPU Modules.....	13
2.1.2 Functions of Local Expansion Modules.....	14
2.1.3 Functions of Remote Expansion Modules	16
2.2 Product System Integration Diagrams	19
2.3 Models and Nameplates.....	21
Chapter 3 Specifications	25
3.1 Application Environment Specifications.....	26
3.2 Hardware Performance Indicators of the CPU Modules	26
3.3 Specifications of the Power Module	30
3.4 Local Expansion Modules	32
3.4.1 DI Modules	32
3.4.2 DO Modules	34
3.4.3 AI Module	38
3.4.4 AO Module.....	40
3.4.5 Temperature Detection Modules.....	42
3.5 Remote Expansion Modules (EtherCAT).....	44
3.5.1 EtherCAT Communication Module.....	44
3.5.2 I/O Modules	46
3.5.3 High-speed Counting Module.....	47
3.5.4 Positioning Module	49
3.6 Remote Expansion Module (PROFIBUS-DP).....	51
3.7 Remote Expansion Module (CANopen)	52

Chapter 4 Installation	55
4.1 Installation Environment Requirements	56
4.1.1 Installation Environment	56
4.1.2 Installation Clearance	56
4.1.3 Installation Instructions	56
4.2 Installation Method	57
4.2.1 Module Installation Process	57
4.2.2 Mounting the DIN Guide Rail to the Installation Plane in the Control Cabinet.....	57
4.2.3 Connecting the Power Module, CPU Module, and Expansion Module.....	58
4.2.4 Mounting the Connected Module Group to the Guide Rail	59
4.2.5 Installing the System Protection Component - Tail Board	61
4.3 Installing and Removing the Terminal Block	61
4.4 Installing and Removing the SD Card	62
4.5 Replacing Modules.....	63
Chapter 5 Wiring.....	67
5.1 Wiring Suggestions	68
5.1.1 Grounding Requirements	68
5.1.2 Wiring Requirements.....	69
5.1.3 Installing the RFI Filter for the Power Module	70
5.1.4 Insulation Transformer	70
5.2 Selecting and Making Cables	71
5.2.1 Selecting Cables	71
5.2.2 Making Fork-lug Cables.....	71
5.2.3 Making Tubular-lug Cables	72
5.3 Wiring of the Power Module	72
5.3.1 Terminal Definition	72
5.3.2 Wiring Precautions	73
5.3.3 Grounding.....	73
5.4 High-speed I/O Wiring of the CPU Module	74
5.4.1 Terminal Signal Arrangement.....	74
5.4.2 Wiring Precautions	74
5.4.3 External Wiring.....	75
5.5 Communication Wiring of the CPU Module	77
5.5.1 Cable Connection Requirements	77

5.5.2 Connection Through the EtherCAT Bus	78
5.5.3 Connection Through the PROFIBUS-DP Bus	80
5.5.4 Connection Through the CANopen/CANlink Bus.....	84
5.5.5 Serial Communication Connection Through RS485.....	85
5.5.6 Monitoring Connection Through Ethernet	88
5.6 Wiring of Local Expansion Modules	90
5.6.1 DI Modules	90
5.6.2 DO Modules	93
5.6.3 AI Module	98
5.6.4 AO Module.....	100
5.6.5 Temperature Detection Modules.....	101
5.7 Wiring of Remote Expansion Modules (EtherCAT)	104
5.7.1 EtherCAT Wiring Requirements	104
5.7.2 Wiring Requirements for User Terminal Output Signals	106
5.7.3 Signal Wiring of the I/O Modules.....	107
5.7.4 Signal Wiring of the High-speed Counting Module.....	109
5.7.5 Signal Wiring of the Positioning Module.....	113
Chapter 6 Programming Tool and Download	117
6.1 Programming Tool Acquisition	118
6.2 Programming Environment and Software Installation	118
6.2.1 Environment Requirements	118
6.2.2 Installation Procedure.....	118
6.2.3 InoProShop Uninstallation	121
Chapter 7 Running and Maintenance	123
7.1 Running and Stop	124
7.2 Indicators and MFK Button.....	124
7.2.1 LED Fault Indicators	124
7.2.2 MFK Button Description	126
7.3 Routine Maintenance.....	126
7.3.1 Daily Spot Check Items	126
7.3.2 Periodic Spot Check	127
7.4 CPU Module LED Display	127
7.4.1 Fault Display Mode	127
7.4.2 Fault Code Display.....	128
Appendix: Revision History	131



Chapter 1 Safety Instructions

Before You Start.....	8
Safety Instructions	8

Before You Start

Thank you for purchasing the Inovance AM600 series programmable logic controller (PLC). This manual describes how to properly use this product. Before using the product (including installation, wiring, running, maintenance, and inspection), read this manual carefully and ensure that you understand the safety instructions. Relevant device vendors must deliver this manual to end users with devices for their later use.

Safety Instructions

Before you install, wire, operate, or inspect this product, read this manual/guide and the related documents mentioned. Exercise safety cautions when performing operations.

Safety information and precautions are classified into three grades: Danger, Warning, and Caution.

 **DANGER** Indicates that failure to comply with the notice will result in severe personal injuries or even death.

 **WARNING** Indicates that failure to comply with the notice may result in severe personal injuries or even death.

 **CAUTION** Indicates that failure to comply with the notice may result in minor personal injuries or damage to the equipment.

In some cases, even failure to follow the instructions in "Caution" may lead to serious consequences.

Therefore, ensure that you follow the instructions in both warnings and cautions. Failure to comply may result in death or serious personal injury and damage to the devices itself, related equipment, and system.

Please keep this manual/guide well for reading when necessary and deliver it to the end user.

Control System Design	
 WARNING	<ul style="list-style-type: none">◆ Use a safety circuit to ensure that the control system continues to work safely when the external power supply or PLC fails.◆ Add a safety device, such as a fuse or circuit breaker, to prevent the module from smoking or catching fire when overcurrent remains in the output circuit for long time due to reasons such as rated current exceeded and load short circuit.

 CAUTION

- ◆ An emergency stop circuit, protection circuit, forward/reverse operation interlocked circuit, and upper position limit and lower position limit interlocked circuit must be set in the external circuits of the PLC to prevent damage to the machine.
- ◆ To ensure safe operation, design external protection circuits and safety mechanisms for output signals that may cause critical accidents.
- ◆ Once the PLC CPU detects a system abnormality, all outputs may be closed; however, when a fault occurs in the controller circuit, the output may not be under control. Therefore, design an appropriate external control circuit to ensure normal operation.
- ◆ If the PLC's output units such as the relay and transistor are damaged, the output may fail to switch between ON and OFF state according to the commands.
- ◆ The PLC is designed to be used in indoor electrical environment (overvoltage category II). The power supply must be equipped with a system-level lightning protection device to ensure that overvoltage caused by lightning shock does not impact the power supply input terminal, signal input terminal, and control output terminal of the PLC, avoiding damage to the equipment.

Installation

 WARNING

- ◆ Installation, wiring, maintenance, and inspection of the equipment must be carried out by professional personnel who have received necessary training and master sufficient electrical knowledge.
- ◆ Disconnect all external power supplies of the system before installing or uninstalling a module. Failure to comply may result in electric shock, module fault, and malfunction.
- ◆ Do not use the PLC in places with dust, oil smoke, conductive dust, or corrosive or combustible gases, or expose the PLC in environment of high temperature, condensation, wind and rain, vibration, or impact. Electric shock, fire, and malfunction may also result in product damage or performance deterioration.
- ◆ The PLC is an open-type device. To protect operators without sufficient knowledge about electrical devices, the PLC must be installed in a control cabinet with a lock (the cabinet housing must provide protection of over IP20). Only personnel who have received necessary training and master sufficient electrical knowledge can open the control cabinet.

 CAUTION

- ◆ Prevent metal filings and wire ends from dropping into ventilation holes of the PLC when making the holes for screws.
- ◆ Failure to comply may result in fire, fault, and malfunction.
- ◆ Ensure that no foreign matters are left on the ventilation surface after the PLC is installed. Failure to comply may result in poor ventilation, causing fire, fault, and malfunction.
- ◆ Ensure that the module is securely connected to the corresponding connector and hook the module firmly during module installation. Improper installation may result in malfunction, fault, or fall-off of the module.

Wiring

 WARNING

- ◆ Installation, wiring, maintenance, and inspection must be carried out by professional personnel who have received necessary training and master sufficient electrical knowledge.
- ◆ Disconnect all external power supplies of the system before wiring. Failure to comply may result in electric shock, device fault, and malfunction.
- ◆ After installation and wiring are complete, install the terminal covers delivered with the equipment before powering on the PLC. Failure to comply may result in electric shock.
- ◆ Ensure good insulation for the cable terminals and keep the insulation distance between cables after connecting cables to the terminal block. Failure to comply may result in electric shock and device damage.
- ◆ Use a proper protection device, which is usually a circuit breaker or external fuse capable of fusing and detection, for the input distribution circuit. Consider factors such as rated current and overload capability of the device and the short-circuit capability of the power distribution in front of the device when selecting a protection device.

Wiring



- ◆ Prevent metal filings and wire ends from dropping into ventilation holes of the PLC when making the holes for screws. Failure to comply may result in fire, fault, and malfunction.
- ◆ The external wiring specifications and installation mode must comply with local regulations. For details, see the wiring section in this manual.
- ◆ To ensure device and operator safety, use cables with sufficient diameter and connect them to the ground reliably. For details, see the wiring section in this manual.
- ◆ Perform wiring properly after you are clear about the connector types. Failure to comply may result in faults of modules and external devices.
- ◆ Tighten the bolts on the terminal block with the specified torque range. If the bolts are not tight, short-circuit, fire, and malfunction may occur. If the bolts are too tight, the bolts and modules may be damaged, resulting in fall-off, short-circuit, fire, or malfunction.
- ◆ If connectors are used to connect to external devices, use tools specified by the manufacturer to crimp or weld the connectors. If the connectors are in poor contact, short-circuit, fire, and malfunction may occur.
- ◆ Stick a label on the top of the module to prevent foreign matters from entering the module during wiring. Do not remove the label during wiring. Remember to remove it before starting the system to ensure good ventilation.
- ◆ Do not bundle control cables, communication cables, main circuit or power cables together. The distance between them must exceed 100 mm to avoid malfunctions caused by noise.
- ◆ Use shielded cables for high-frequency signal input/output in applications with serious interference to improve the anti-interference capability of the system.
- ◆ Do not use external power supply for 24+ terminals of the basic or expansion units.

Operations and Maintenance



- ◆ Installation, wiring, maintenance, and inspection of the product must be carried out by professional personnel who have received necessary training and master sufficient electrical knowledge.
- ◆ Do not touch the terminals when the power is on. Failure to comply may result in electric shock or malfunction.
- ◆ Disconnect all external power supplies of the system before cleaning modules or retightening the bolts on the terminal block or the connector bolts. Failure to comply may result in electric shock.
- ◆ Disconnect all external power supplies of the system before installing or uninstalling modules or connecting or disconnecting the communication cables. Failure to comply may result in electric shock or malfunction.



- ◆ Read the manual carefully and ensure safety before performing operations such as online modification, forcible output, RUN, and STOP.
- ◆ Disconnect the power supply before installing or removing the extension card.
- ◆ Replace the button cell when the system is powered off. Battery replacement with the power on can be performed only by professional electrical technicians who wear insulation gloves. Battery replacement must be completed within 30 seconds; otherwise, the data is lost.

Disposal



- ◆ Dispose the product as industrial waste.
- ◆ Battery disposal must be performed separately according to the local laws.

Transport



- ◆ Lithium battery transport must comply with the transport regulations.



Chapter 2 Product Information

2.1 Product System Assembly.....	12
2.1.1 Functions of the CPU Modules.....	13
2.1.2 Functions of Local Expansion Modules.....	14
2.1.3 Functions of Remote Expansion Modules.....	16
2.2 Product System Integration Diagrams.....	19
2.3 Models and Nameplates.....	21

■ Overview

The AM600 is a modularized medium-sized PLC. Each rack can contain 16 local expansion modules and support remote rack expansion through industrial fieldbuses such as PROFIBUS-DP, EtherCAT, and CANopen.

I/O expansion for the AM600 local expansion modules, including the digital input/output modules, analog input/output modules, temperature detection modules, and remote function modules, is based on the internal bus protocol.

The analog input/output modules have the following features:

- 1) Use 16-bit resolution conversion integrated circuits to achieve higher signal conversion accuracy.
- 2) Support single-axis point-to point positioning via high-speed IO with maximum 200kHz frequency output.
- 3) Support 16-axis and 32-axis for PTP positioning and provides the single-axis acceleration/ deceleration control, electronic gear, and electronic cam functions.

2.1 Product System Assembly

A normally-running AM600 system must include the following three modules:

- 1) Power module: The power module is mandatory for the local and remote racks. It converts AC power into DC power and supplies DC power to other parts on the guide rail. Each local rack and remote rack must be equipped with a power module (220 V input and 24 V/2 A output).

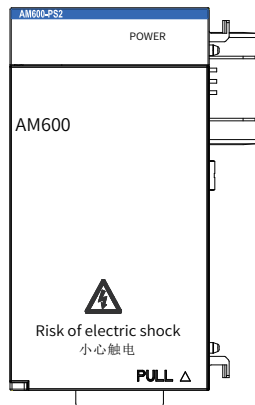

- 2) CPU module: The CPU module (including the tail board) is the core of the AM600 system and functions as the management and control center of the system. For details about the related functions, see Section ["2.1.1 Function Description of the CPU Module"](#).

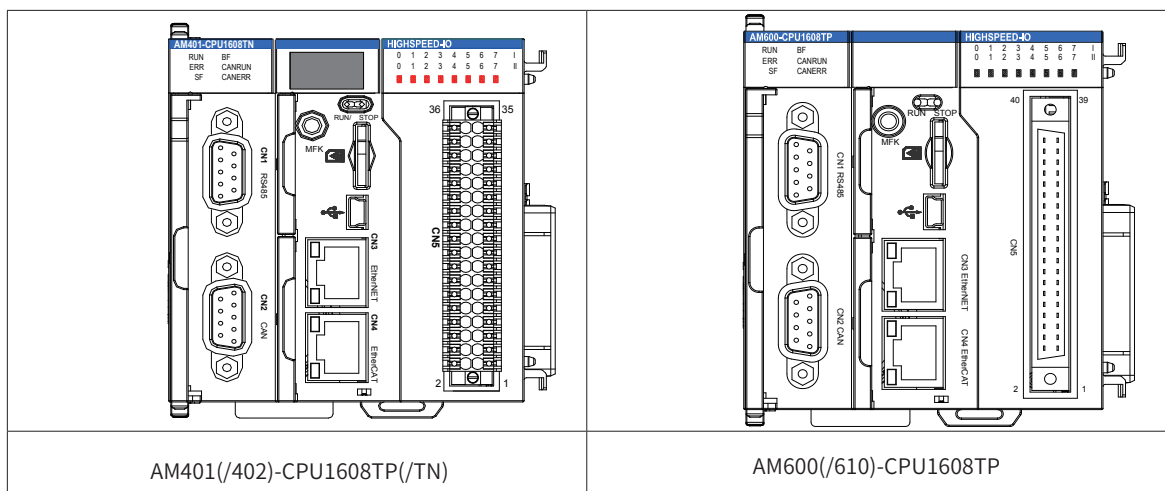

- 3) Guide rail: The AM600 series use a modularized structure. The power module, CPU module, and expansion modules must be installed on the guide rail and then fixed to the corresponding plane.
Note: Use the standard DIN35 guide rail and ensure that it is not deformed or painted with isolating varnish and that its electrical conductivity is excellent. You can buy the guide rail yourself.



In addition to the preceding modules, you can select expansion modules based on requirements to build the local or remote control system. For details about the local expansion modules, remote expansion modules, and module wiring, see Section ["2.1.2 Functions of Local Expansion Modules"](#), Section ["2.1.3 Functions of Remote Expansion Modules"](#), and ["Chapter 5 Wiring"](#) respectively.

2.1.1 Functions of the CPU Module

CPU Module Model	Local Expansion Module Count ^[1]	Program Storage Space	Data Storage Space	Number of Axes	High-speed I/O Function	Output Type	Communication							
							RS485	LAN	EtherCAT	PROFIBUS-DP	CANopen/CANlink	Modbus/TCP	Modbus (serial)	
AM401-CPU1608TP	8	4 MB	8 MB	4	Built-in 16-in-8-out high-speed I/O	Source output	√ (1 channel)	√ (1 channel)	√ (Supports 125 stations.)	×	√	×	×	
AM402-CPU1608TP				8										×
AM401-CPU1608TN				4		Sink output	√ (1 channel)	√ (1 channel)		×	√	×	×	×
AM402-CPU1608TN				8										
AM600-CPU1608TP	16	4 MB	8 MB	32	Built-in 16-in-8-out high-speed I/O	Source output	√ (2 channels)	√ (1 channel)	√ (Supports 125 stations.)	×	√ (Number of supported stations up to 63)	×	×	
AM610-CPU1608TP to M8306	16			×										Source output

[1] The power module and end cover are excluded.

■ Communication ports of the CPU module

Communication Ports of the CPU Module	Communication Protocol	Cable	Application	Matching Module
CN1	Modbus-RTU	DB9	Two RS485 ports, supporting the Modbus protocol	-
CN2	PROFIBUS-DP	DB9	The maximum baud rate of PROFIBUS-DP is 12 Mbit/s	AM600-RTU-DP
	CANopen/CANlink	DB9	Inovance CANlink/CANopen industrial control network. The maximum CAN communication rate is 1 Mbit/s.	AM600-RTU-COP
CN3	Ethernet protocol and Modbus-TCP	Network cable	Host PC or HMI communication/remote monitoring/data exchange/industrial control network	-

Communication Ports of the CPU Module	Communication Protocol	Cable	Application	Matching Module
CN4	EtherCAT	Cat5e shielded twisted pair cable	Industrial control network. The maximum communication rate is 100 Mbit/s.	AM600-RTU-ECT AM600-RTU-ECTA AM600-0808ETNE AM600-1616ETNE AM600-2HCE AM600-4PME
USB	-	Mini USB	PC communication and program download and debugging	-

2.1.2 Functions of Local Expansion Modules

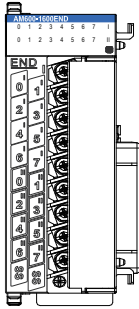
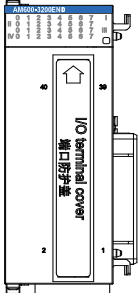
Model	Appearance	Category	Description	Order Code
AM600-1600END (GL10-1600END)		DI modules	16-channel DI module; DC 24 V input; source/sink	0144005
AM600-3200END (GL10-3200END) *GL10-3200END have spring clamp type terminal			32-channel DI module; DC 24 V input; source/sink	01440023

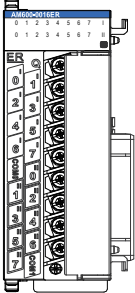
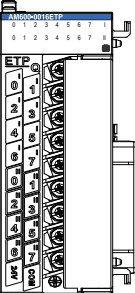
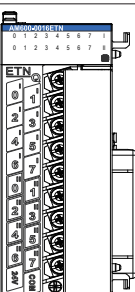
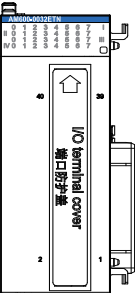
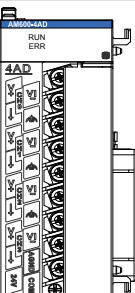
Model	Appearance	Category	Description	Order Code
AM600-0016ER (GL10-0016ER)		DO modules	16-channel DO module; relay output	01440017
AM600-0016ETP (GL10-0016ETP)			16-channel DO module; transistor output (source)	01440003
AM600-0016ETN (GL10-0016ETN)			16-channel DO module; transistor output (sink)	01440018
AM600-0032ETN (GL10-0032ETN) *GL10-3200END have spring clamp type terminal		DO module	32-channel DO module; transistor output (sink)	01440025
AM600-4AD (GL10-4AD)		AI module	4-channel AD module; support voltage/ current analog input	01440006

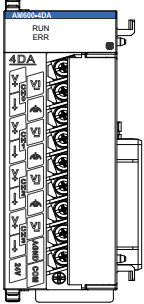
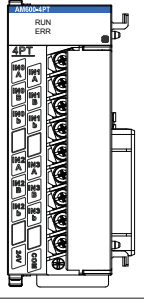
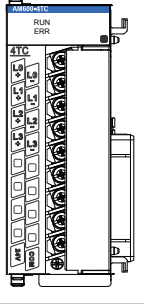
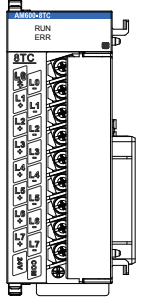
Model	Appearance	Category	Description	Order Code
AM600-4DA (GL10-4DA)		AO module	4-channel DA module; support voltage/ current analog output	01440007
AM600-4PT (GL10-4PT)		Temperature detection modules	4-channel temperature measuring for multiple types of thermal resistors	01440008
AM600-4TC (GL10-4TC)			4-channel temperature measuring for multiple types of thermocouples	01440009
AM600-8TC (GL10-8TC)			8-channel temperature measuring for multiple types of thermocouples	01440026

2.1.3 Functions of Remote Expansion Modules

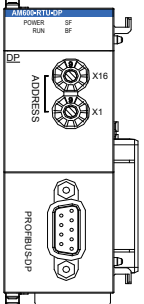
Model	Appearance	Category	Description	Order Code
AM600-RTU-DP *sunset		PROFIBUS-DP communication module	PROFIBUS-DP-based communication module; supports the Profibus-DP fieldbus.	01440012

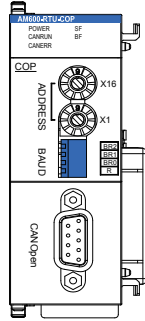
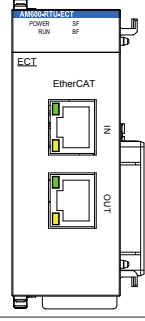
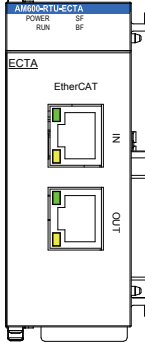
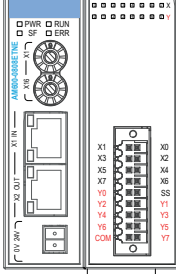
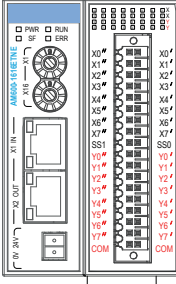
Model	Appearance	Category	Description	Order Code
AM600-RTU-COP (GL10-RTU-COP)		CANopen communication module	CANopen-based communication module: supports the CANopen fieldbus.	01440011
AM600-RTU-ECT		EtherCAT communication module	EtherCAT-based communication module: supports the EtherCAT fieldbus.	01440013
AM600-RTU-ECTA (GL10-RTU-ECTA)		EtherCAT communication module	EtherCAT-based communication module: supports the EtherCAT fieldbus and automatic scan.	01440033
AM600-0808ETNE (GR10-0808ETNE)		EtherCAT communication I/O module	16-channel digital module for EtherCAT-based communication: supports the EtherCAT fieldbus and 8 digital inputs and 8 digital outputs.	01440027
AM600-1616ETNE (GR10-0808ETNE)		EtherCAT communication I/O module	32-channel digital module for EtherCAT-based communication: supports the EtherCAT fieldbus and 16 digital inputs and 16 digital outputs.	01440030

Model	Appearance	Category	Description	Order Code
AM600-4PME (GR10-4PME)		EtherCAT communication positioning module	4-channel positioning output module for EtherCAT-based communication: supports the EtherCAT fieldbus and 4-channel positioning outputs.	01440035
AM600-2HCE (GR10-2HCE)		EtherCAT communication high-speed counting module	2-channel high-speed counting module for EtherCAT-based communication: supports the EtherCAT fieldbus and 2-channel ABZ high-speed counting.	01440036

2.2 Product System Integration Diagrams

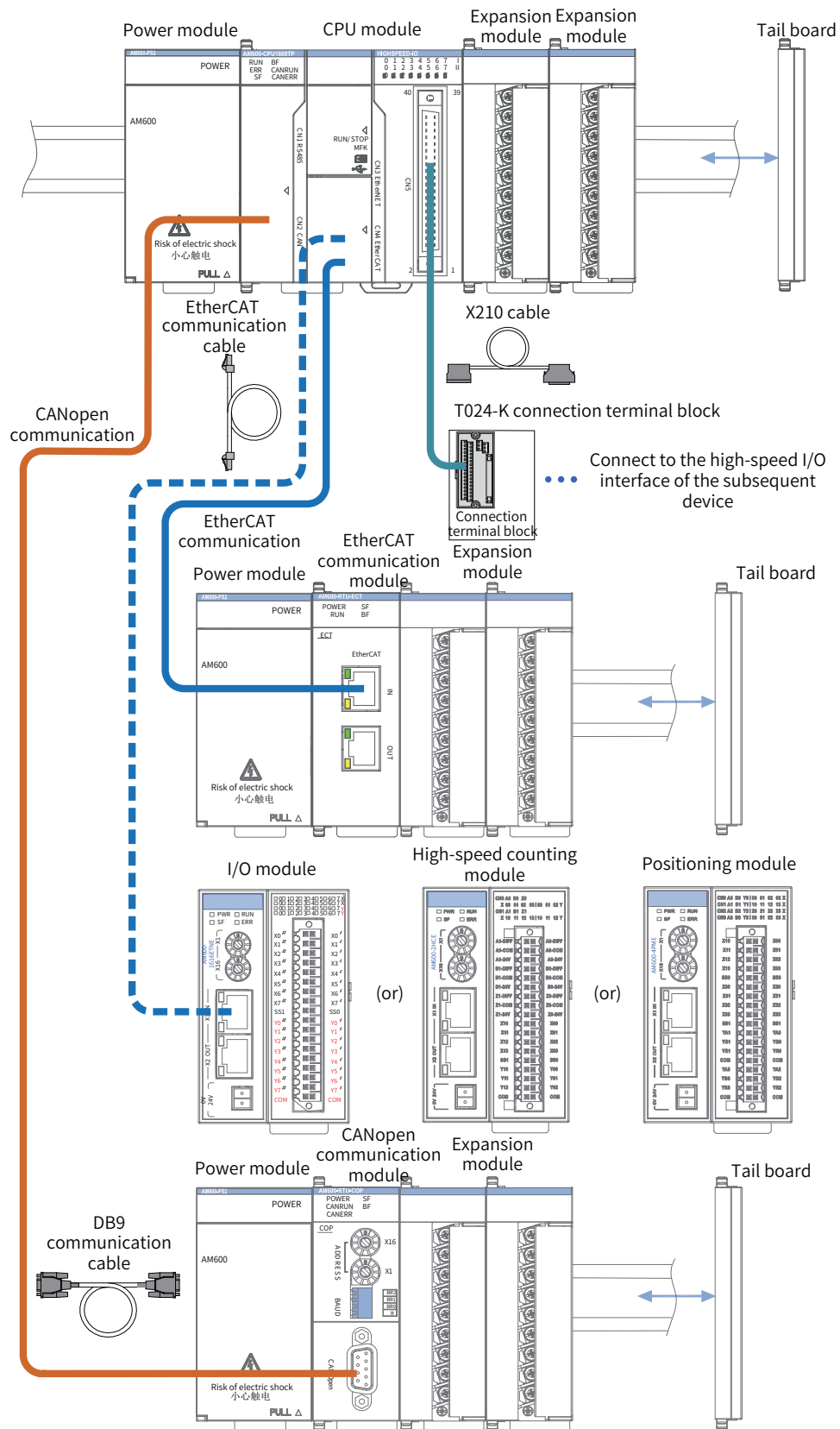

Figure 2-1 System integration (AM600-CPU1608TP)

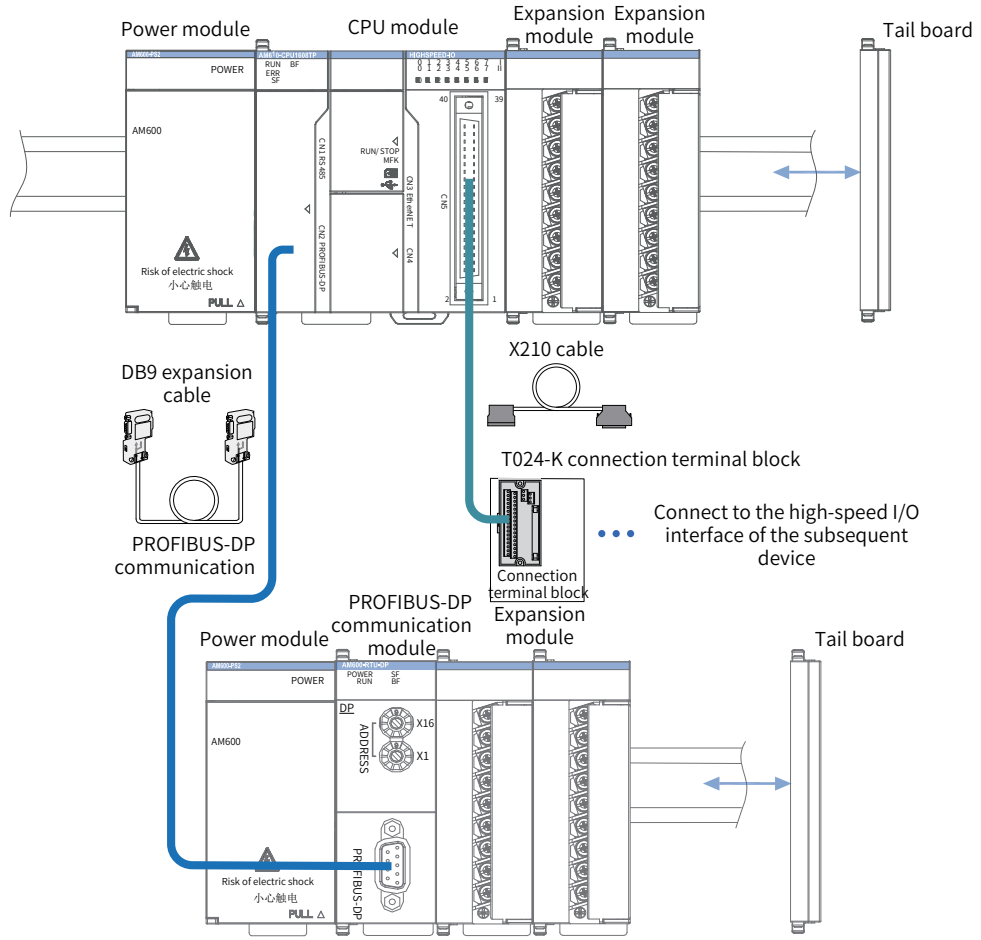

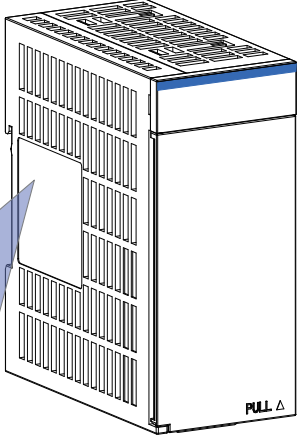

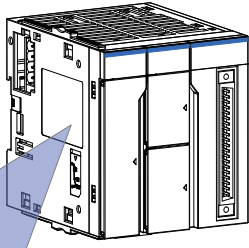

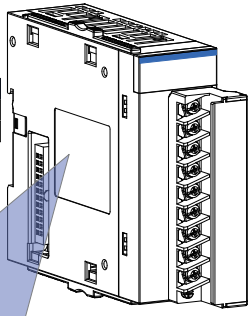

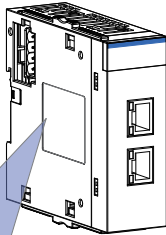
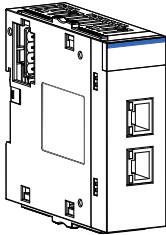
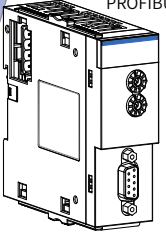
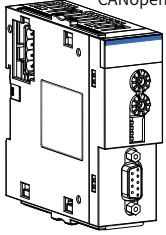

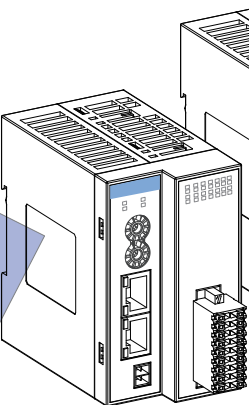
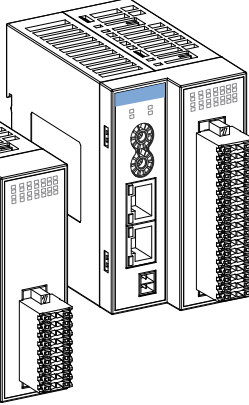

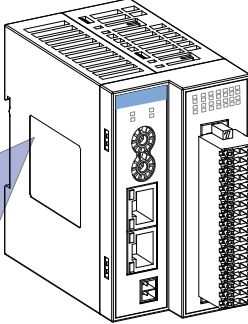

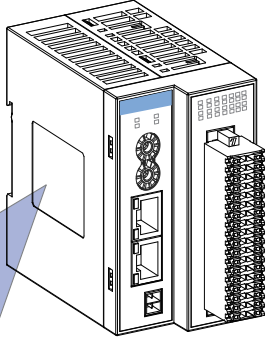

Figure 2-2 System integration (AM610-CPU1608TP)

2.3 Models and Nameplates

Module	Model and Nameplate																
Power module	<h3 style="text-align: center;">AM600-PS2</h3> <div style="display: flex; justify-content: space-around;"> <table border="1"> <tr><th>Product Information</th></tr> <tr><td>AM Inovance medium-sized PLC Automation-Motion</td></tr> </table> <table border="1"> <tr><th>Series</th></tr> <tr><td>600 600 series PLC</td></tr> </table> <table border="1"> <tr><th>Module Type</th></tr> <tr><td>PS Power module</td></tr> </table> <table border="1"> <tr><th>Output Current</th></tr> <tr><td>2 2 A</td></tr> <tr><td>3 3 A</td></tr> <tr><td>5 5 A</td></tr> </table> </div> <div style="border: 1px solid black; padding: 10px; margin-top: 10px;"> <p>Nameplate</p> <p>MODEL: AM600-PS2 POWER INPUT: 100-240 VAC 1 A 50/60 Hz OUTPUT: 24 VDC 2 A VER: xxxxx 01022087YE400001  01022087YE400001</p> </div> 	Product Information	AM Inovance medium-sized PLC Automation-Motion	Series	600 600 series PLC	Module Type	PS Power module	Output Current	2 2 A	3 3 A	5 5 A						
Product Information																	
AM Inovance medium-sized PLC Automation-Motion																	
Series																	
600 600 series PLC																	
Module Type																	
PS Power module																	
Output Current																	
2 2 A																	
3 3 A																	
5 5 A																	
CPU modules	<h3 style="text-align: center;">AM600-CPU1608TP</h3> <div style="display: flex; justify-content: space-around;"> <table border="1"> <tr><th>Product Information</th></tr> <tr><td>AM Inovance medium-sized PLC Automation-Motion</td></tr> </table> <table border="1"> <tr><th>Series</th></tr> <tr><td>401 1 x RS485 channel, 1 x LAN, EtherCAT bus, and 4 x DSP402 slave stations supported</td></tr> <tr><td>402 1 x RS485, 1 x LAN, EtherCAT bus, and 8 x DSP402 slave stations supported</td></tr> <tr><td>600 2 x RS485, 1 x CANopen/CANlink, 1 x LAN, EtherCAT bus</td></tr> <tr><td>610 2 x RS485, 1 x LAN, PROFIBUS-DP bus</td></tr> </table> <table border="1"> <tr><th>Module Type</th></tr> <tr><td>CPU CPU module</td></tr> </table> <table border="1"> <tr><th>High-speed I/Os</th></tr> <tr><td>16 16 inputs</td></tr> <tr><td>08 8 outputs</td></tr> </table> <table border="1"> <tr><th>IO Output Mode</th></tr> <tr><td>TP Source</td></tr> <tr><td>TN Sink</td></tr> </table> </div> <div style="border: 1px solid black; padding: 10px; margin-top: 10px;"> <p>Nameplate</p> <p>MODEL: AM600-CPU1608TP POWER INPUT: 24 VDC 1 A OUTPUT: 24 VDC 0.1 A RES LOAD VER: xxxxx 01022087YE400001  01022087YE400001</p> </div> 	Product Information	AM Inovance medium-sized PLC Automation-Motion	Series	401 1 x RS485 channel, 1 x LAN, EtherCAT bus, and 4 x DSP402 slave stations supported	402 1 x RS485, 1 x LAN, EtherCAT bus, and 8 x DSP402 slave stations supported	600 2 x RS485, 1 x CANopen/CANlink, 1 x LAN, EtherCAT bus	610 2 x RS485, 1 x LAN, PROFIBUS-DP bus	Module Type	CPU CPU module	High-speed I/Os	16 16 inputs	08 8 outputs	IO Output Mode	TP Source	TN Sink	
Product Information																	
AM Inovance medium-sized PLC Automation-Motion																	
Series																	
401 1 x RS485 channel, 1 x LAN, EtherCAT bus, and 4 x DSP402 slave stations supported																	
402 1 x RS485, 1 x LAN, EtherCAT bus, and 8 x DSP402 slave stations supported																	
600 2 x RS485, 1 x CANopen/CANlink, 1 x LAN, EtherCAT bus																	
610 2 x RS485, 1 x LAN, PROFIBUS-DP bus																	
Module Type																	
CPU CPU module																	
High-speed I/Os																	
16 16 inputs																	
08 8 outputs																	
IO Output Mode																	
TP Source																	
TN Sink																	
DI modules	<h3 style="text-align: center;">AM600-1600END</h3> <div style="display: flex; justify-content: space-around;"> <table border="1"> <tr><th>Product Information</th></tr> <tr><td>AM Inovance medium-sized PLC Automation-Motion</td></tr> </table> <table border="1"> <tr><th>Series</th></tr> <tr><td>600 600 series PLC</td></tr> </table> <table border="1"> <tr><th>Inputs</th></tr> <tr><td>16 16 inputs</td></tr> <tr><td>32 32 points</td></tr> </table> <table border="1"> <tr><th>Module Type</th></tr> <tr><td>E Logical I/O expansion module</td></tr> </table> <table border="1"> <tr><th>Input Signal</th></tr> <tr><td>D 24 VDC</td></tr> <tr><td>A 110 to 220 VAC</td></tr> </table> </div> <div style="display: flex; justify-content: center; margin-top: 10px;"> <table border="1" style="margin-right: 20px;"> <tr><th>Outputs</th></tr> <tr><td>00 0</td></tr> </table> <table border="1"> <tr><th>Module Type</th></tr> <tr><td>N No output</td></tr> </table> </div> <div style="border: 1px solid black; padding: 10px; margin-top: 10px;"> <p>Nameplate</p> <p>MODEL: AM600-1600END POWER INPUT: NONE OUTPUT: NONE VER: xxxxx 01022087YE400001  01022087YE400001</p> </div> 	Product Information	AM Inovance medium-sized PLC Automation-Motion	Series	600 600 series PLC	Inputs	16 16 inputs	32 32 points	Module Type	E Logical I/O expansion module	Input Signal	D 24 VDC	A 110 to 220 VAC	Outputs	00 0	Module Type	N No output
Product Information																	
AM Inovance medium-sized PLC Automation-Motion																	
Series																	
600 600 series PLC																	
Inputs																	
16 16 inputs																	
32 32 points																	
Module Type																	
E Logical I/O expansion module																	
Input Signal																	
D 24 VDC																	
A 110 to 220 VAC																	
Outputs																	
00 0																	
Module Type																	
N No output																	

Module	Model and Nameplate															
DO modules	<h2 style="text-align: center;">AM600-0016ETP</h2> <div style="display: flex; justify-content: space-around; align-items: flex-start;"> <table border="1" style="font-size: 8px;"> <tr><th>Product Information</th></tr> <tr><td>AM Inovance medium-sized PLC Automation-Motion</td></tr> </table> <table border="1" style="font-size: 8px;"> <tr><th>Series</th></tr> <tr><td>600 600 series PLC</td></tr> </table> <table border="1" style="font-size: 8px;"> <tr><th>Inputs</th></tr> <tr><td>00 0</td></tr> </table> <table border="1" style="font-size: 8px;"> <tr><th>Module Type</th></tr> <tr><td>E Logical I/O expansion module</td></tr> </table> <table border="1" style="font-size: 8px;"> <tr><th>Output Type</th></tr> <tr><td>R Relay</td></tr> <tr><td>TP Transistor (source)</td></tr> <tr><td>TN Transistor (sink)</td></tr> </table> </div> <div style="margin-top: 10px;"> <table border="1" style="font-size: 8px;"> <tr><th>Outputs</th></tr> <tr><td>16 16 outputs</td></tr> <tr><td>32 32 outputs</td></tr> </table> </div> <div style="margin-top: 20px; border: 1px solid black; padding: 5px;"> <p>Nameplate</p> <p>MODEL: AM600-0016ETP POWER INPUT: 24 VDC 2 A OUTPUT(PNP): 24 VDC 0.5 A RES LOAD VER: xxxxx 01022087YE400001 01022087YE400001</p> </div>	Product Information	AM Inovance medium-sized PLC Automation-Motion	Series	600 600 series PLC	Inputs	00 0	Module Type	E Logical I/O expansion module	Output Type	R Relay	TP Transistor (source)	TN Transistor (sink)	Outputs	16 16 outputs	32 32 outputs
Product Information																
AM Inovance medium-sized PLC Automation-Motion																
Series																
600 600 series PLC																
Inputs																
00 0																
Module Type																
E Logical I/O expansion module																
Output Type																
R Relay																
TP Transistor (source)																
TN Transistor (sink)																
Outputs																
16 16 outputs																
32 32 outputs																
Analog modules	<h2 style="text-align: center;">AM600- 4 AD</h2> <div style="display: flex; justify-content: space-around; align-items: flex-start;"> <table border="1" style="font-size: 8px;"> <tr><th>Product Information</th></tr> <tr><td>AM Inovance medium-sized PLC Automation-Motion</td></tr> </table> <table border="1" style="font-size: 8px;"> <tr><th>Series</th></tr> <tr><td>600 600 series PLC</td></tr> </table> <table border="1" style="font-size: 8px;"> <tr><th>Channel Count</th></tr> <tr><td>4 4 channels</td></tr> </table> <table border="1" style="font-size: 8px;"> <tr><th>Channel & Input Type</th></tr> <tr><td>AD Analog input</td></tr> <tr><td>DA Analog output</td></tr> <tr><td>AM Mixed module</td></tr> </table> </div> <div style="margin-top: 20px; border: 1px solid black; padding: 5px;"> <p>Nameplate</p> <p>MODEL: AM600-4AD POWER INPUT: 24 VDC 100 mA OUTPUT: NONE VER: xxxxx 01022087YE400001 01022087YE400001</p> </div>	Product Information	AM Inovance medium-sized PLC Automation-Motion	Series	600 600 series PLC	Channel Count	4 4 channels	Channel & Input Type	AD Analog input	DA Analog output	AM Mixed module					
Product Information																
AM Inovance medium-sized PLC Automation-Motion																
Series																
600 600 series PLC																
Channel Count																
4 4 channels																
Channel & Input Type																
AD Analog input																
DA Analog output																
AM Mixed module																
Temperature detection modules	<h2 style="text-align: center;">AM600-4PT</h2> <div style="display: flex; justify-content: space-around; align-items: flex-start;"> <table border="1" style="font-size: 8px;"> <tr><th>Product Information</th></tr> <tr><td>AM Inovance medium-sized PLC Automation-Motion</td></tr> </table> <table border="1" style="font-size: 8px;"> <tr><th>Series</th></tr> <tr><td>600 600 series PLC</td></tr> </table> <table border="1" style="font-size: 8px;"> <tr><th>Channel Count</th></tr> <tr><td>4 4 channels</td></tr> <tr><td>8 8 channels</td></tr> </table> <table border="1" style="font-size: 8px;"> <tr><th>Input Type</th></tr> <tr><td>PT Thermal resistor</td></tr> <tr><td>TC Thermocouple</td></tr> </table> </div> <div style="margin-top: 20px; border: 1px solid black; padding: 5px;"> <p>Nameplate</p> <p>MODEL: AM600-4PT POWER INPUT: 24 VDC 100 mA OUTPUT: NONE VER: xxxxx 01022087YE400001 01022087YE400001</p> </div>	Product Information	AM Inovance medium-sized PLC Automation-Motion	Series	600 600 series PLC	Channel Count	4 4 channels	8 8 channels	Input Type	PT Thermal resistor	TC Thermocouple					
Product Information																
AM Inovance medium-sized PLC Automation-Motion																
Series																
600 600 series PLC																
Channel Count																
4 4 channels																
8 8 channels																
Input Type																
PT Thermal resistor																
TC Thermocouple																

Module	Model and Nameplate																		
<p>Communication modules</p>	<h2 style="text-align: center;">AM600-RTU-ECT</h2> <div style="display: flex; justify-content: space-around;"> <table border="1" data-bbox="379 412 528 472"> <tr><th>Product Information</th></tr> <tr><td>AM Invoance medium-sized PLC Automation-Motion</td></tr> </table> <table border="1" data-bbox="539 412 683 472"> <tr><th>Series</th></tr> <tr><td>600 600 series PLC</td></tr> </table> <table border="1" data-bbox="694 412 799 472"> <tr><th>Module Type</th></tr> <tr><td>Remote interface module</td></tr> </table> <table border="1" data-bbox="810 412 927 551"> <tr><th>Remote Communication protocols</th></tr> <tr><td>ECT EtherCAT</td></tr> <tr><td>ECTA Auto-scan supported</td></tr> <tr><td>DP PROFIBUS-DP</td></tr> <tr><td>COP CANopen</td></tr> </table> </div> <div style="margin-top: 20px;"> <p>Nameplate</p> <p>MODEL: AM600-RTU-ECT POWER INPUT: 24 VDC 1 A OUTPUT: NONE VER: xxxxx 01022087YE400001</p>  <p>01022087YE400001</p> </div> <div style="display: flex; justify-content: space-around; margin-top: 20px;">   </div> <div style="display: flex; justify-content: space-around; margin-top: 20px;">   </div>	Product Information	AM Invoance medium-sized PLC Automation-Motion	Series	600 600 series PLC	Module Type	Remote interface module	Remote Communication protocols	ECT EtherCAT	ECTA Auto-scan supported	DP PROFIBUS-DP	COP CANopen							
Product Information																			
AM Invoance medium-sized PLC Automation-Motion																			
Series																			
600 600 series PLC																			
Module Type																			
Remote interface module																			
Remote Communication protocols																			
ECT EtherCAT																			
ECTA Auto-scan supported																			
DP PROFIBUS-DP																			
COP CANopen																			
<p>EtherCAT communication I/O modules</p>	<h2 style="text-align: center;">AM600-0808ETNE</h2> <div style="display: flex; justify-content: space-around;"> <table border="1" data-bbox="363 990 491 1050"> <tr><th>Product Information</th></tr> <tr><td>AM Invoance medium-sized PLC Automation-Motion</td></tr> </table> <table border="1" data-bbox="502 990 614 1050"> <tr><th>Series</th></tr> <tr><td>600 600 series PLC</td></tr> </table> <table border="1" data-bbox="625 990 705 1050"> <tr><th>Inputs</th></tr> <tr><td>08 8 inputs</td></tr> <tr><td>16 16 inputs</td></tr> </table> <table border="1" data-bbox="716 990 821 1050"> <tr><th>Module Type</th></tr> <tr><td>E Logical I/O expansion module</td></tr> </table> <table border="1" data-bbox="833 990 954 1072"> <tr><th>Output Type</th></tr> <tr><td>R Replay</td></tr> <tr><td>TP Transistor (source)</td></tr> <tr><td>TN Transistor (sink)</td></tr> </table> </div> <div style="margin-top: 20px;"> <table border="1" data-bbox="705 1093 785 1128"> <tr><th>Outputs</th></tr> <tr><td>08 8 outputs</td></tr> <tr><td>16 16 outputs</td></tr> </table> <table border="1" data-bbox="821 1093 954 1128"> <tr><th>Others</th></tr> <tr><td>E EtherCAT communication module</td></tr> </table> </div> <div style="margin-top: 20px;"> <p>Nameplate</p> <p>MODEL: AM600-0808ETNE POWER INPUT: DC24 V OUTPUT(PNP): DC24 V 0.5 A RES LOAD VER: xxxxx 01022087 YE 400001</p>  <p>01022087 YE 400001</p> </div> <div style="display: flex; justify-content: space-around; margin-top: 20px;">   </div>	Product Information	AM Invoance medium-sized PLC Automation-Motion	Series	600 600 series PLC	Inputs	08 8 inputs	16 16 inputs	Module Type	E Logical I/O expansion module	Output Type	R Replay	TP Transistor (source)	TN Transistor (sink)	Outputs	08 8 outputs	16 16 outputs	Others	E EtherCAT communication module
Product Information																			
AM Invoance medium-sized PLC Automation-Motion																			
Series																			
600 600 series PLC																			
Inputs																			
08 8 inputs																			
16 16 inputs																			
Module Type																			
E Logical I/O expansion module																			
Output Type																			
R Replay																			
TP Transistor (source)																			
TN Transistor (sink)																			
Outputs																			
08 8 outputs																			
16 16 outputs																			
Others																			
E EtherCAT communication module																			
<p>EtherCAT communication high-speed counting module</p>	<h2 style="text-align: center;">AM600-2HCE</h2> <div style="display: flex; justify-content: space-around;"> <table border="1" data-bbox="422 1585 582 1646"> <tr><th>Product Information</th></tr> <tr><td>AM Invoance medium-sized PLC Automation-Motion</td></tr> </table> <table border="1" data-bbox="593 1585 737 1646"> <tr><th>Series</th></tr> <tr><td>600 600 series PLC</td></tr> </table> <table border="1" data-bbox="748 1585 828 1646"> <tr><th>Channel Count</th></tr> <tr><td>2 2 channels</td></tr> </table> <table border="1" data-bbox="839 1585 944 1646"> <tr><th>Module Type</th></tr> <tr><td>HC High-speed counting module</td></tr> </table> <table border="1" data-bbox="956 1585 1077 1646"> <tr><th>Auxiliary Function</th></tr> <tr><td>E EtherCAT communication</td></tr> </table> </div> <div style="margin-top: 20px;"> <p>Nameplate</p> <p>MODEL: AM600-2HCE POWER INPUT: 24 VDC 250 mA OUTPUT: 24 VDC 0.5 A RES LOAD VER: xxxxx 01022087YE400001</p>  <p>01022087YE400001</p> </div> <div style="display: flex; justify-content: space-around; margin-top: 20px;">  </div>	Product Information	AM Invoance medium-sized PLC Automation-Motion	Series	600 600 series PLC	Channel Count	2 2 channels	Module Type	HC High-speed counting module	Auxiliary Function	E EtherCAT communication								
Product Information																			
AM Invoance medium-sized PLC Automation-Motion																			
Series																			
600 600 series PLC																			
Channel Count																			
2 2 channels																			
Module Type																			
HC High-speed counting module																			
Auxiliary Function																			
E EtherCAT communication																			

Module	Model and Nameplate																				
EtherCAT communication positioning module	<div style="text-align: center; font-size: 24pt; font-weight: bold;">AM600-4PME</div> <div style="display: flex; justify-content: center; gap: 10px; margin-top: 10px;"> <table border="1" style="font-size: 8pt;"> <thead> <tr> <th colspan="2">Product Information</th> <th colspan="2">Series</th> <th colspan="2">Channel Count</th> <th colspan="2">Module Type</th> <th colspan="2">Auxiliary Function</th> </tr> </thead> <tbody> <tr> <td>AM</td> <td>Inovance medium-sized PLC Automation-Motion</td> <td>600</td> <td>600 series PLC</td> <td>4</td> <td>4 channels</td> <td>PM</td> <td>Positioning module</td> <td>E</td> <td>EtherCAT communication</td> </tr> </tbody> </table>  </div> <div style="margin-top: 20px;"> <div style="border: 1px solid black; padding: 5px; width: fit-content;"> <p>Nameplate</p> <p>MODEL: AM600-4PME POWER INPUT: 24 VDC 250 mA OUTPUT: 24 VDC 0.5 A RES LOAD VER: xxxxx 01022087YE400001</p>  <p>01022087YE400001</p> </div> </div>	Product Information		Series		Channel Count		Module Type		Auxiliary Function		AM	Inovance medium-sized PLC Automation-Motion	600	600 series PLC	4	4 channels	PM	Positioning module	E	EtherCAT communication
	Product Information		Series		Channel Count		Module Type		Auxiliary Function												
AM	Inovance medium-sized PLC Automation-Motion	600	600 series PLC	4	4 channels	PM	Positioning module	E	EtherCAT communication												



Chapter 3 Specifications

3.1 Application Environment Specifications.....	26
3.2 Hardware Performance Indicators of the CPU Modules	26
3.3 Specifications of the Power Module	30
3.4 Local Expansion Modules	32
3.4.1 DI Modules	32
3.4.2 DO Modules	34
3.4.3 AI Module	38
3.4.4 AO Module.....	40
3.4.5 Temperature Detection Modules.....	42
3.5 Remote Expansion Module (EtherCAT).....	44
3.5.1 EtherCAT Communication Module.....	44
3.5.2 I/O Modules	46
3.5.3 High-speed Counting Module.....	47
3.5.4 Positioning Module	49
3.6 Remote Expansion Module (PROFIBUS-DP).....	51
3.7 Remote Expansion Module (CANopen)	52

3.1 Application Environment Specifications

	Parameter Type	Working Environment	Transport Environment	Storage Environment	
Environment parameters (IEC60721-3)	Environment class	IE33	IE22	IE12	
	Temperature	-5°C to 55°C	-40°C to 70°C	-25°C to 70°C	
	Humidity	10% to 95% without condensation			
	Vibration	Frequency	5 Hz to 150 Hz	2M2	1M2
		Displacement	3.5 mm (direct installation) (< 9 Hz)		
		Acceleration	1 G (direct installation) (> 9 Hz)		
		Direction	3 axial load directions		
Impact	15 G, 11 ms, half-sine wave, and 3 axial load directions				
Altitude/air pressure	0 m to 2000 m	0 m to 3000 m (>70 kPa)			

3.2 Hardware Performance Indicators of the CPU Modules

1 Basic specifications of the CPU modules

Item	Specifications																																							
Programming language	IEC 61131-3 programming languages (LD, FBD, IL, ST, SFC, and CFC)																																							
Program execution mode	Compiling																																							
User program storage space	4 MB																																							
Flash non volatile storage space	512 KB																																							
SD card capacity	Up to 32 GB																																							
Soft elements and features	<table border="1"> <thead> <tr> <th rowspan="2">Element</th> <th rowspan="2">Name</th> <th rowspan="2">Count</th> <th colspan="3">Storage Feature</th> </tr> <tr> <th>Default</th> <th>Storage Attribute Change</th> <th>Description</th> </tr> </thead> <tbody> <tr> <td>I</td> <td>Input relay</td> <td>64K words</td> <td>Not saved</td> <td>No</td> <td rowspan="4">X: 1 bit B: 8 bits W: 16 bits D: 32 bits L: 64 bits</td> </tr> <tr> <td>Q</td> <td>Output relay</td> <td>64K words</td> <td>Not saved</td> <td>No</td> </tr> <tr> <td rowspan="2">M</td> <td rowspan="2">Auxiliary relay</td> <td rowspan="2">240K words</td> <td>-</td> <td>-</td> </tr> <tr> <td>Saved</td> <td>Yes</td> </tr> <tr> <td>SM</td> <td>Special mark</td> <td>10000 bits</td> <td>Saved</td> <td>Special use</td> <td>Special mark</td> </tr> <tr> <td>SD</td> <td>Special register</td> <td>10000 words</td> <td>Saved</td> <td>Special use</td> <td>Special register</td> </tr> </tbody> </table>	Element	Name	Count	Storage Feature			Default	Storage Attribute Change	Description	I	Input relay	64K words	Not saved	No	X: 1 bit B: 8 bits W: 16 bits D: 32 bits L: 64 bits	Q	Output relay	64K words	Not saved	No	M	Auxiliary relay	240K words	-	-	Saved	Yes	SM	Special mark	10000 bits	Saved	Special use	Special mark	SD	Special register	10000 words	Saved	Special use	Special register
	Element				Name	Count	Storage Feature																																	
		Default	Storage Attribute Change	Description																																				
	I	Input relay	64K words	Not saved	No	X: 1 bit B: 8 bits W: 16 bits D: 32 bits L: 64 bits																																		
	Q	Output relay	64K words	Not saved	No																																			
	M	Auxiliary relay	240K words	-	-																																			
Saved				Yes																																				
SM	Special mark	10000 bits	Saved	Special use	Special mark																																			
SD	Special register	10000 words	Saved	Special use	Special register																																			
Program non volatile storage mode	Flash storage or SD card storage (If the power failure occurs within 35 seconds after power-on, non volatile storage is not triggered.)																																							
Output current of the internal 5 V power supply	1500 mA (rated)																																							
Interruption mode	8-channel input interruption (CPU module high-speed DI), supporting rising edge and falling edge interruption																																							

2 External interfaces of the CPU modules

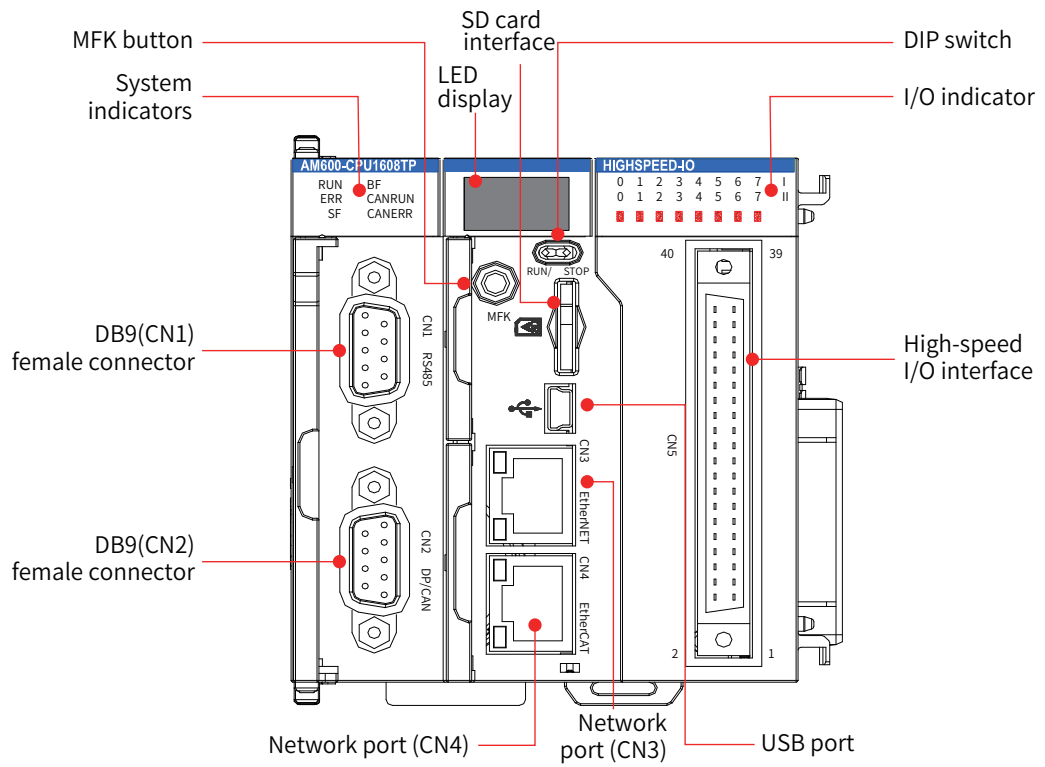

Figure 3-3 Interfaces of the CPU modules (AM600-CPU1608TP as an example)

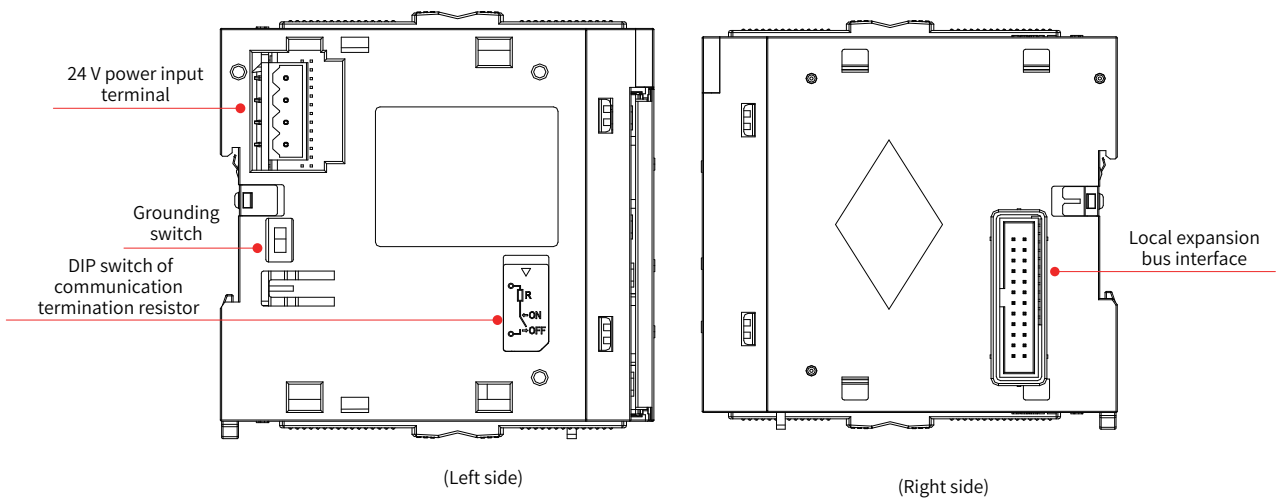
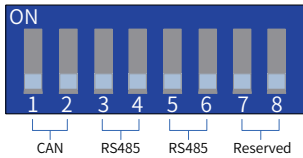
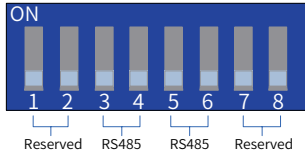

Figure 3-4 Interfaces of the CPU modules (AM600-CPU1608TP is used as an example)

Interface Name	Function Definition	
	AM600-CPU1608TP	AM610-CPU1608TP
DB9 (CN1)/(female socket)	Two RS485 ports, supporting the Modbus protocol.	
DB9 (CN2)/(female socket)	1. CANopen protocol 2. CANlink protocol	PROFIBUS-DP protocol
Network port (CN4)	EtherCAT protocol	None
Network port (CN3)	1. Modbus TCP 2. Standard Ethernet function 3. System program debugging 4. User program download and debugging (supporting only IPv4)	
USB	Program download and debugging	
High-speed I/O	16-channel high-speed input 8-channel high-speed output	
Input/output signal indicator	16-channel input/8-channel output signal indicator	
DIP switch	RUN/STOP DIP switch	
SD card interface	Stores user programs and user data	
MFK button	MFK multi-function button	
Indicator	RUN: running indicator	
	ERR: CPU running error indicator	
	SF: system error indicator	
	BF: bus error indicator	
	CANRUN: CANopen/CANlink running indicator	None
	CANERR: CANopen/CANlink error indicator	None
LED display	Displays warning information and responses of the MFK button.	
Local expansion bus interface	A maximum of 16 I/O modules can be added. The number and configuration of the modules vary depending on power consumption of the modules. The modules are not hot-pluggable.	
24 V power input terminal	DC 24 V voltage input, used when the controller is powered by the AM600 power module.	
Grounding switch	Switch of the connection between the internal digital ground and the housing ground. By default, the switch is off. The switch is used only when the internal digital ground is used as the reference plane. It is not recommended that you operate it to avoid affecting system stability.	
DIP switch of communication termination resistor	<p>If a switch is set to ON, the termination resistor is connected. By default, the switches are all set to OFF. Switches 1 and 2 are for CAN-based communication, switches 3 and 4 are for the first channel of RS485-based communication, switches 5 and 6 are for the second channel of RS485-based communication, and switches 7 and 8 are reserved.</p> 	
	<p>If a switch is set to ON, the termination resistor is connected. By default, the switches are all set to OFF. Switches 3 and 4 are for COM1 communication (RS485), switches 5 and 6 are for COM0 communication (RS485), and other switches are reserved.</p> 	

3 Basic I/O specifications of the CPU modules

■ Digital inputs specifications

Item	Specifications		
Signal name	High-speed input (differential or single-end) (X0-X5)		High-speed input (single-end) (X6-XF)
	24 V input	Differential input	24 V input
Rated input voltage	24 V DC (+20% to -15%, pulsation within 5%)	EIA standard RS-422-A differential line drive level (equivalent to AM26LS31)	24 V DC (+20% to -15%, pulsation within 5%)
Rated input current	7.3 mA (typical value) (for DC 24 V)		7.3 mA (typical value) (for DC 24 V)
ON current	Above 5 mA		Above 5 mA
OFF current	Below 1.5 mA		Below 1.5 mA
Input resistance	3.3 k Ω		3.3 k Ω
Max. counting speed	800 Kbps (2-phase fourfold Frequency Multiplication), 200 kHz (single-channel input)		
Duty cycle range of the 2-phase input	(40%:60%) to (60%:40%)		
Common terminal mode	Independent common terminal for each channel.	--	One common terminal for every five channels

■ Digital outputs specifications

Item	Specifications
Signal name	Output (Y0-Y7)
Output polarity	Source output (high level output, PNP type)
Control circuit voltage	DC 5 V to 24 V
Rated load current	0.1 A/channel, 0.5 A/COM
Max. voltage drop upon ON	0.2 V (typical value)
Leakage current upon OFF	Below 0.1 mA
Output frequency	200 kHz (the external equivalent load of the user must be higher than 12 mA.)
Common terminal mode	One common terminal for every four channels

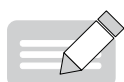

NOTE

- ◆ The total extended distance of the extension cable of the high-speed I/O interface must be less than 3.0 m.
- ◆ The duty cycle must be greater than 40% when two-phase (phase A and phase B) input mode is adopted.

4 Dimensions

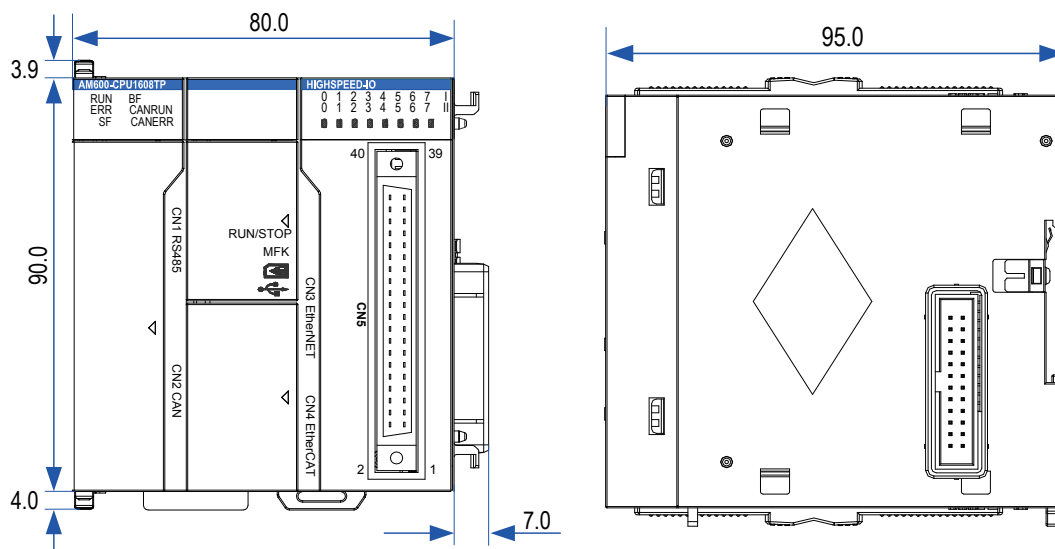

Figure 3-5 Dimensions of the CPU modules (AM600-CPU1608TP as an example)

3.3 Specifications of the Power Module

1 Basic specifications

Item	Name	Rated Value	Test Conditions	Remarks
Insulation resistance	Primary side - SELV	$\geq 2 \times 10^6 \Omega$	Ambient temperature: $25 \pm 5^\circ\text{C}$, relative humidity: $< 90\%$ (without condensation), test voltage: 500 V DC	Comply with LVD directive.
	Primary side - PE	$\geq 2 \times 10^6 \Omega$		
Voltage resistance	Enhanced insulation	Primary side - SELV: Capable of withstanding 3250 VDC (or 2300 VAC) for one minute	No arcing or breakdown with the leakage current lower than 10 mA.	
	Basic insulation	Primary side - PE (or grounding housing): Capable of withstanding 1900 VDC (or 1350 VAC) for one minute		
Pulse	Enhanced insulation	Primary side - SELV: Capable of withstanding 4250 V pulses	No arcing or breakdown	
	Basic insulation	Primary side - PE (or grounding housing): Capable of withstanding 2500 V pulses		
Rated input voltage range	AC input	100 VAC to 240 VAC (-15% to +10%)	-	
Input frequency		50/60 Hz (-5% to +5%)	-	
Rated input current		Up to 1.0 A	-	
Output voltage		24 VDC $\pm 5\%$	-	
Rated output current		2 A	-	
Efficiency		Above 70%	-	
IP class		IP20	-	
Overvoltage class		Pluggable or fixed devices that obtain power from indoor sockets	-	
Overcurrent protection device		2 A fuse	Internal fuse	

2 Module interfaces description

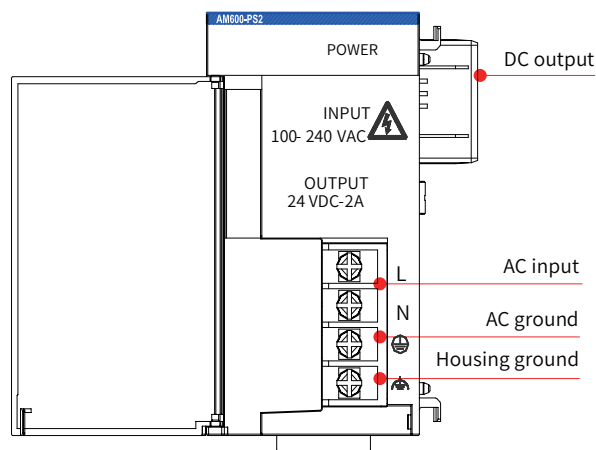



Figure 3-6 Interfaces of the power module

The power module has two terminals. the AC input terminal and the DC output terminal. The AC input terminal must meet the following requirements:

Name	Function
AC input	100 VAC to 240 VAC input
	Protective ground (connected to the ground wire of the AC input power)
	Function ground (connected to the system housing)

The DC output terminal must meet the following requirements:

Terminal Symbol	Function	Remarks
24 V	24 V DC output	-
5 V	5 V DC output	If the module does not have the 5 V DC output, this terminal is not connected in the module.
GND	DC output ground	-
GND	DC output ground	-

3 Dimensions (mm)

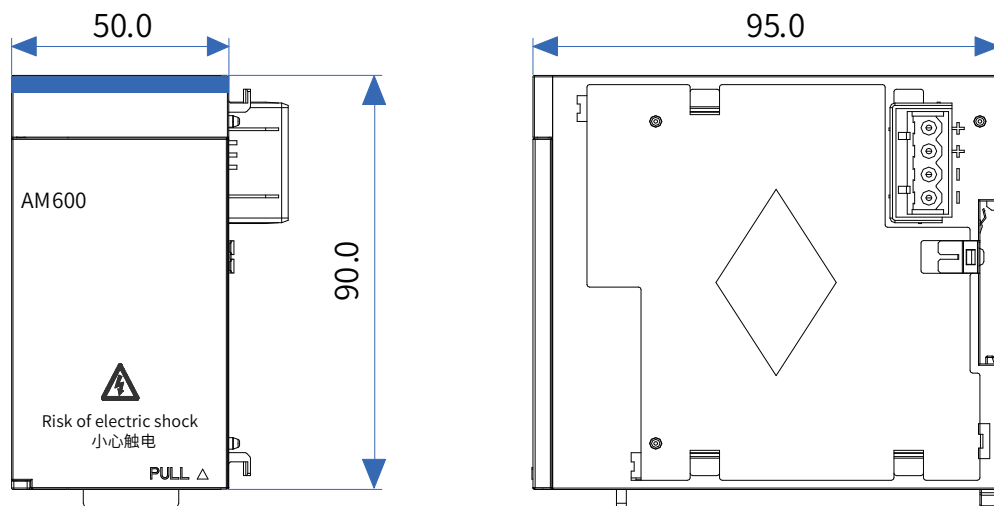

Figure 3-7 Dimensions of the power module

3.4 Local Expansion Modules

3.4.1 DI Modules

1) Basic specifications

Item	Specifications	
	AM600-1600END/GL10-1600END	AM600-3200END/GL10-3200END
Input channel	16	32
Input connecting mode	18-channel wiring terminal	40-pin high density terminal
Input type	DI	DI
Input mode	Sink/Source	Sink/Source
Input voltage class	24 VDC (maximum: 30 V)	24 VDC (maximum: 30 V)
Power consumption of the internal 5 V power supply	55 mA (typical value)	65 mA (typical value)
Input current (typical)	5.3 mA	4 mA
ON voltage	> 15 VDC	> 19 VDC
OFF voltage	< 5 VDC	< 5 VDC
Port filter time	10 ms	10 ms
Input resistance	4.3 k Ω	5.6 k Ω
Input signal mode	DC voltage input, supporting sink/source input	DC voltage input, supporting sink/source input
Isolation method	Opto-couplers isolation	Opto-couplers isolation
Input action display	Input indicator ON when the input is active	Input indicator ON when the input is active

■ AM600-3200END power de-rating diagram

To ensure module application reliability and safety, the number of used channels needs to be de-rated based on the ambient temperature, especially when the ambient temperature is high.

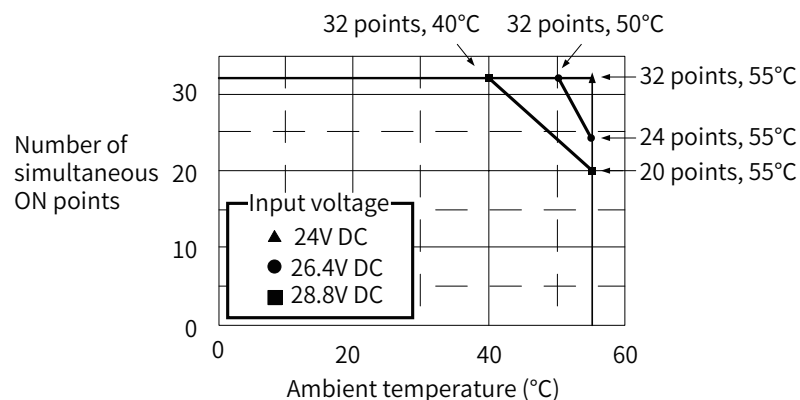

Figure 3-8 DI module (AM600-3200END) power de-rating

2) Module interfaces description

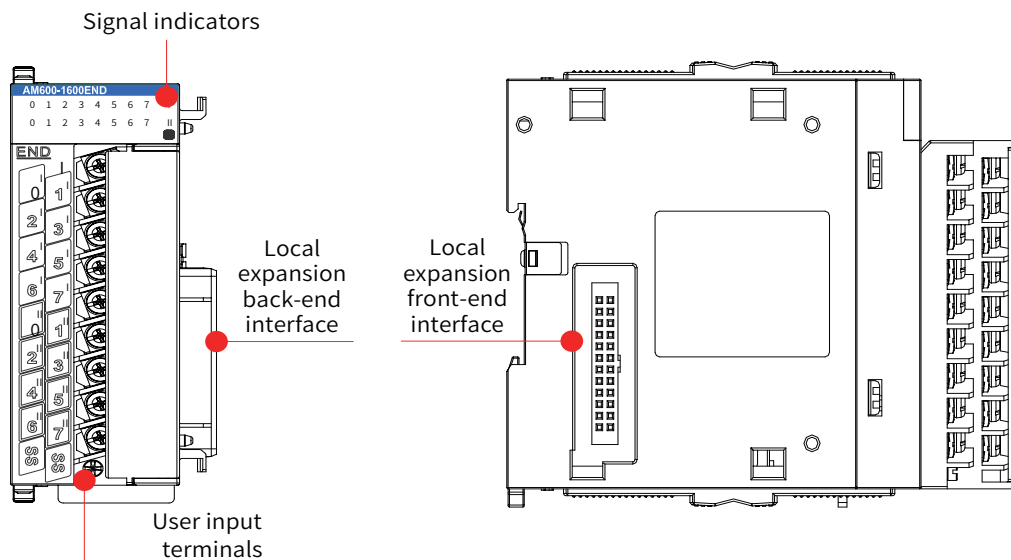

Figure 3-9 DI module (AM600-1600END) interfaces

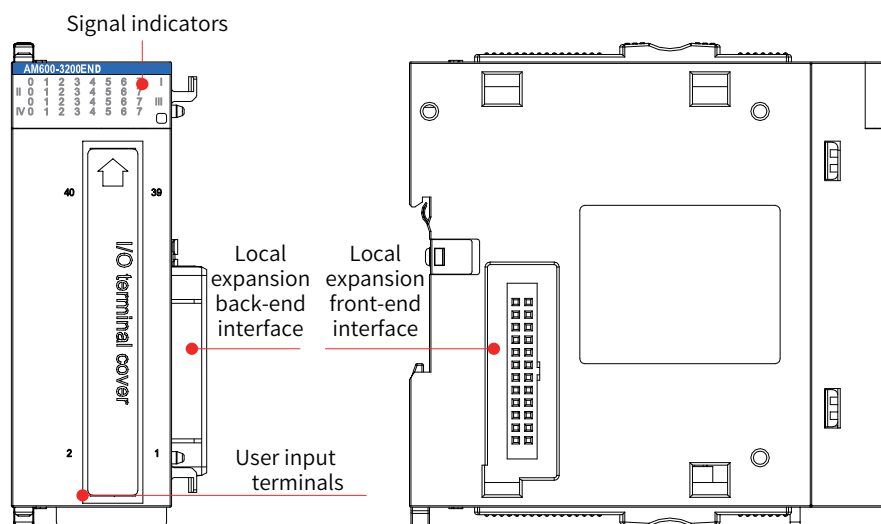

Figure 3-10 DI module (AM600-3200END) interfaces

Interface Name	Function	
	AM600-1600END/GL10-1600END	AM600-3200END/GL10-3200END
User input terminals	8 inputs x 2	8 inputs x 4
Signal indicators	LED status indicator: ON: input active OFF: input inactive	
Local expansion module back-end interface	Connects to the backward module and does not support hot swap. For details about the use, see " Chapter 4 Installation ".	
Local expansion module front-end interface	Connects to the forward module and does not support hot swap. For details about the use, see " Chapter 4 Installation ".	

3) Dimensions (mm)

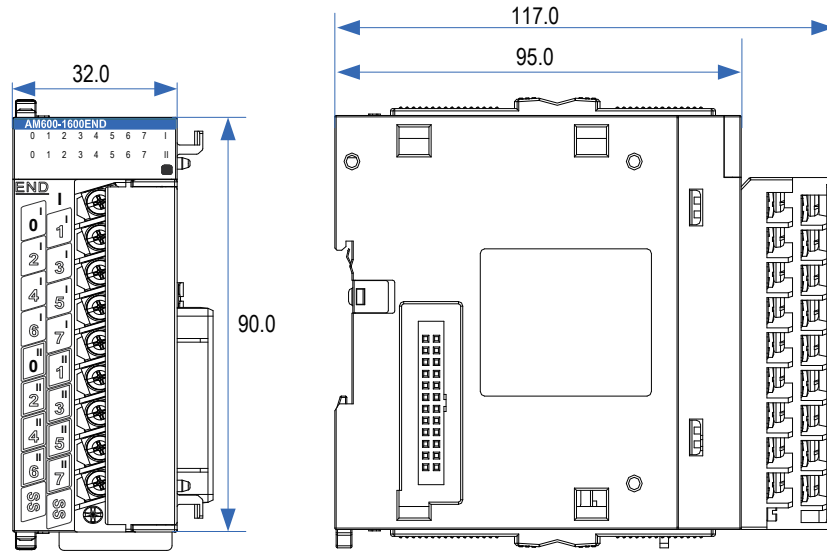

Figure 3-11 Dimensions of DI module (AM600-1600END)

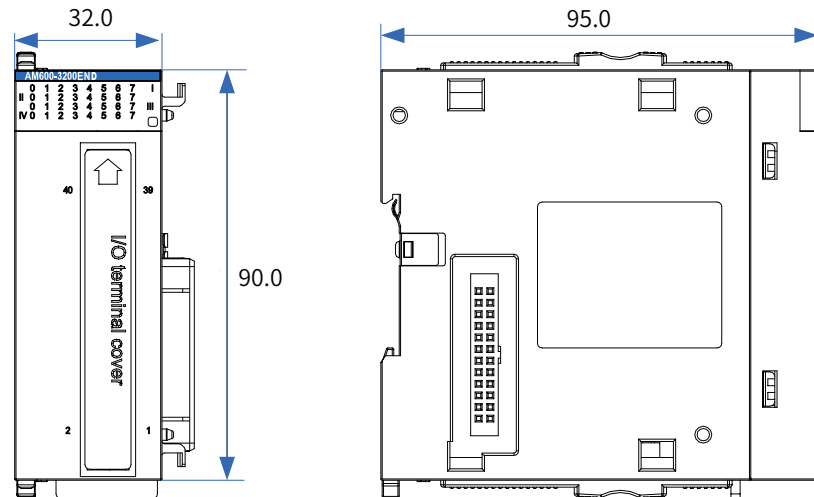

Figure 3-12 Dimensions of DI module (AM600-3200END)

3.4.2 DO Modules

1) Basic specifications

■ Basic specifications of the transistor output modules

Item	AM600-0016ETP/GL10-0016ETP	AM600-0016ETN/GL10-0016ETN	AM600-0032ETN/GL10-0032ETN
Output channels	16	16	32
Output connecting mode	18-channel wiring terminal	18-channel wiring terminal	40-pin high density terminal
Output Type	Transistor, PNP	Transistor, NPN	Transistor, NPN
Output mode	SOURCE	SINK	SINK
Power supply voltage	24 VDC (-15% to +20%)		
Output voltage class	12 to 24 V (-15% to +20%)		
Power consumption of the internal 5 V power supply	65 mA (typical value)	85 mA (typical value)	115 mA (typical value)

Item	AM600-0016ETP/GL10-0016ETP	AM600-0016ETN/GL10-0016ETN	AM600-0032ETN/GL10-0032ETN
OFF max. leakage current	Below 0.5 mA		
ON response time	Below 0.5 ms (hardware response time)		
OFF response time	Below 0.5 ms (hardware response time)		
Max. load	Resistive load	0.5 A/channel, 2 A/common	
	Inductive load	12 W/24 VDC (total)	
	Lamp load	2 W/24 VDC (total)	
Isolation method	Opto-couplers isolation		
Output action display	Output indicator ON when opto-coupler driving is applied		
Short circuit-proof output	Yes (The current is limited to the range of 1 A to 1.7 A when short circuit protection is applied.)	None	Yes

■ Basic specifications of the relay output module

Item	AM600-0016ER/GL10-0016ER	
Output channels	16	
Output connecting mode	16+2 (COM) channel wiring terminal	
Power supply of the module ^[1]	24 VDC (-15% to +20%)	
Output Type	Relay output	
Output mode	Dry contact	
Voltage of the output control circuit	110 VAC to 220 VAC	
Power consumption of the internal 5 V power supply	65 mA (typical value)	
Rated current of relay	240 VAC/24 VDC, 2 A	
OFF max. leakage current	-	
ON response time	Below 20 ms (hardware response time)	
OFF response time	Below 20 ms (hardware response time)	
Max. load	Resistive load	Single-channel 1 A/channel
	Lamp load	Single-channel 30 W
	Inductive load	220 VAC, 2 A/1 channel
	Capacitive load	Not recommended
Isolation method	Mechanical isolation	
Output action display	Output indicator ON when the relay is excited	

[1] The power supply of the module is connected through an independent 2-pin terminal.

2) Module interfaces description

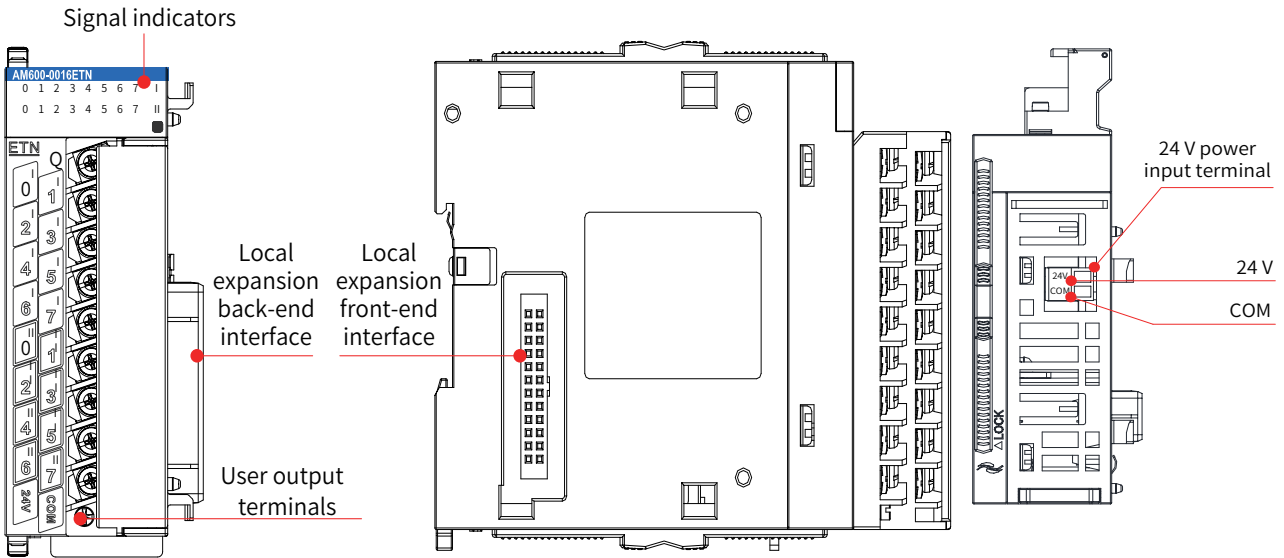

Figure 3-13 DO modules (AM600-0016ETP, AM600-0016ETN, and AM600-0016ER) interfaces

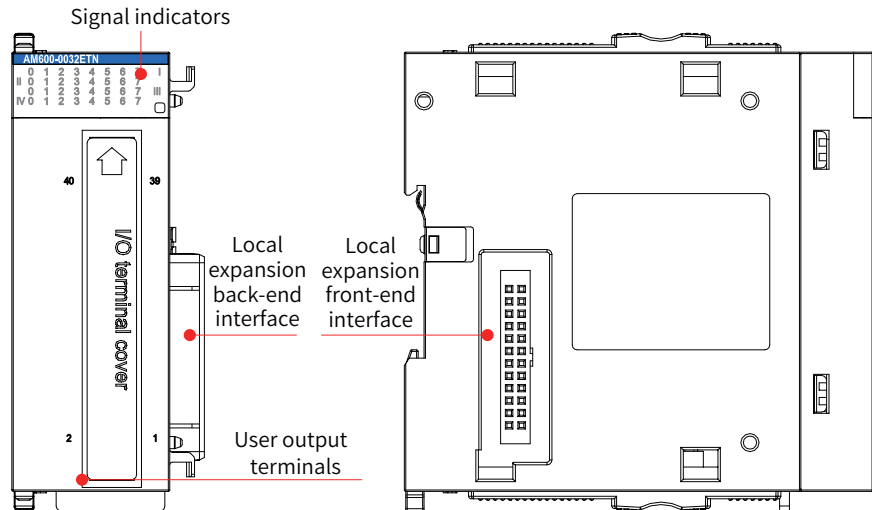

Figure 3-14 DO module (AM600-0032ETN) interfaces

Interface Name	Function	
	AM600-0016ETP, AM600-0016ETN, and AM600-0016ER	AM600-0032ETN
User output terminals	8 outputs x 2	8-channels outputs x 4
Signal indicator	Corresponds to various output signals. ON: output active OFF: output inactive	
Local expansion module back-end interface	Connects to the backward module and does not support hot swap. For details about the use, see " Chapter 4 Installation ".	
Local expansion module front-end interface	Connects to the forward module and does not support hot swap. For details about the use, see " Chapter 4 Installation ".	

3) Dimensions (mm)

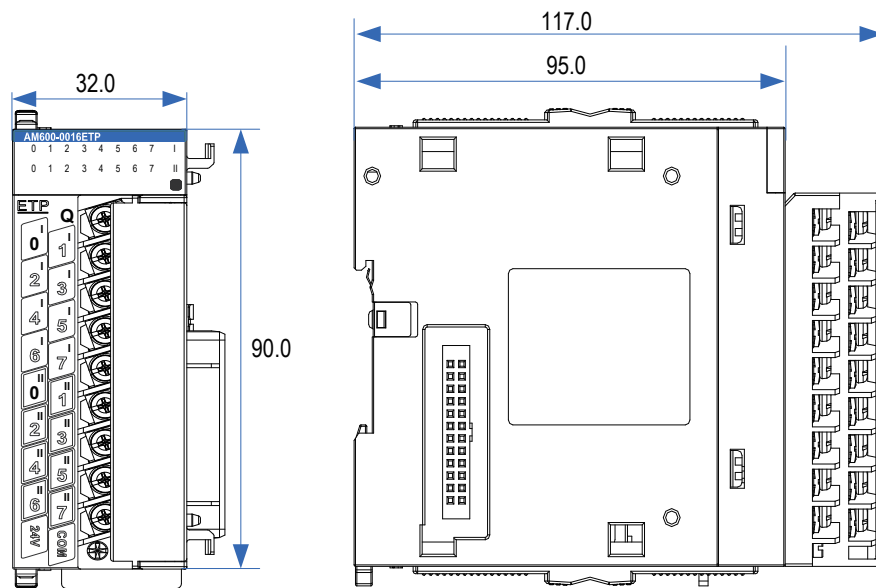

Figure 3-15 Dimensions of DO modules (AM600-0016ETP, AM600-0016ETN, and AM600-0016ER)

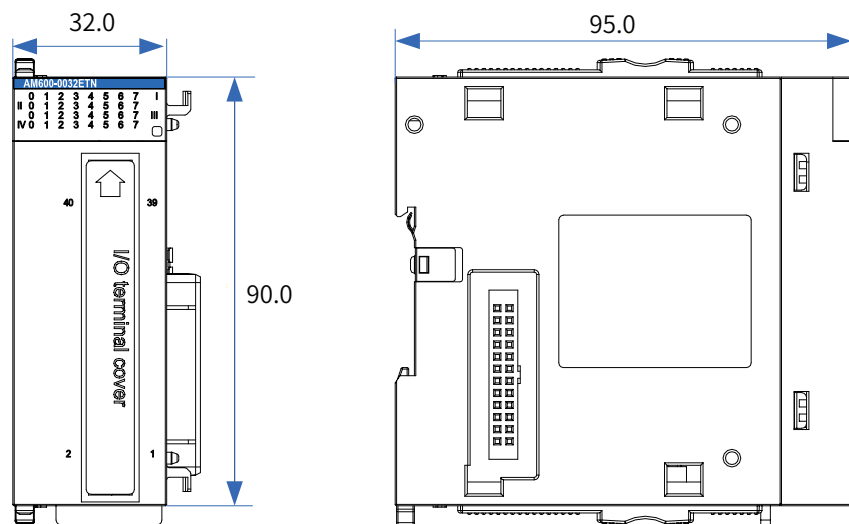

Figure 3-16 Dimensions of DO module (AM600-0032ETN)

3.4.3 AI Module

A 4 analog input module (AM600-4AD/GL10-4AD) is provided.

1) Basic specifications

Item	AM600-4AD/GL10-4AD
Input channels	4
Power supply voltage	24 VDC (20.4 VDC to 28.8 VDC) (-15% to +20%)
Power consumption of the internal 5 V power supply	85 mA (typical value)
Voltage input impedance	> 1 M Ω
Current sampling impedance	250 Ω
Voltage input range	Bipolar: ± 5 V, ± 10 V; Unipolar: +5 V, +10 V
Current input range	0 mA to 20 mA, 4 mA to 20 mA, ± 20 mA
Resolution	16 bits
Sampling time	1 ms
Accuracy (normal temperature: 25°C)	Voltage: $\pm 0.1\%$, current: $\pm 0.1\%$ (full ranges)
Accuracy (ambient temperature: 0°C to 55°C)	Voltage: $\pm 0.3\%$, current: $\pm 0.8\%$
Voltage limits	± 15 V
Current limits	± 30 mA (transient), ± 24 mA (average)
Maximum common mode voltage between channels	30 VDC
Isolation method	Isolation between I/O terminals and power supply No isolation between channels
System program update mode	USB port

The relationship between the actual analog input and the digital values is as follows:

Type	Rated Input Range	Corresponding Digital Value Range	Input Limit Range	Corresponding Digital Value Range
Analog voltage input	-10 V to 10 V	-20,000 to 20,000	-11 V to 11 V	-22,000 to 22,000
	0 V to 10 V	0 to 20000	-0.5 V to 10.5 V	-1000 to +21,000
	-5 V to 5 V	-20,000 to 20,000	-5.5 V to 5.5 V	-22,000 to 22,000
	0 V to 5 V	0 to 20000	-0.25 V to 5.25 V	-1000 to +21,000
	1 V to 5 V	0 to 20000	0.8 V to 5.2 V	-1000 to +21,000
Analog current input	-20 mA to 20 mA	-20,000 to 20,000	-22 mA to 22 mA	-22,000 to 22,000
	0 mA to 20 mA	0 to 20000	-1 mA to 21 mA	-1000 to +21,000
	4 mA to 20 mA	0 to 20000	3.2 mA to 20.8 mA	-1000 to +21,000

2) Module interfaces description

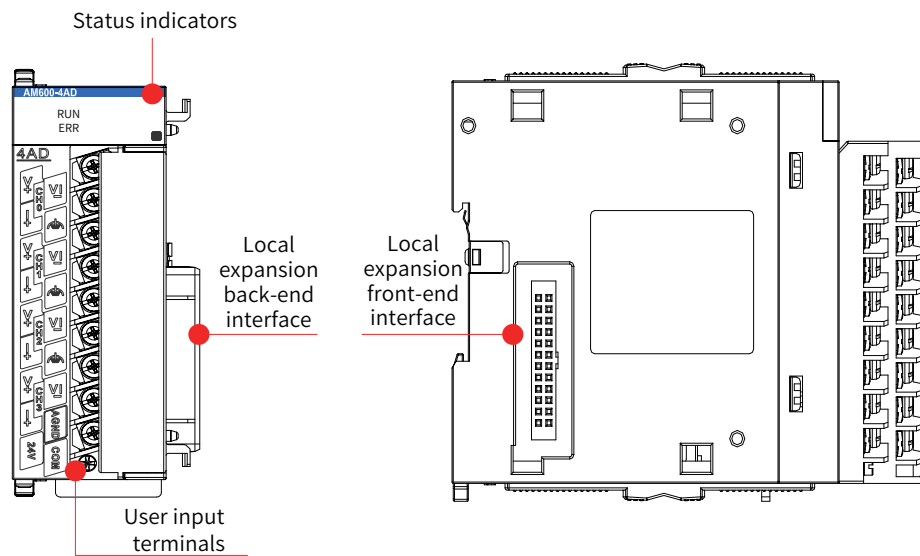

Figure 3-17 Interfaces of the AI module(AM600-4AD)

Interface Name	Function
User input terminals	4-channel input (voltage and current input supported. For details about the use, see "Chapter 5 Wiring" .)
Status indicators	RUN: operation state indicator, which is on during normal operation and off when a fault occurs. ERR: error state indicator, which is on when a fault occurs.
Local expansion module back-end interface	Connects to the backward module and does not support hot swap. For details about the use, see "Chapter 4 Installation"
Local expansion module front-end interface	Connects to the forward module and does not support hot swap. For details about the use, see "Chapter 4 Installation" .

3) Dimensions (mm)

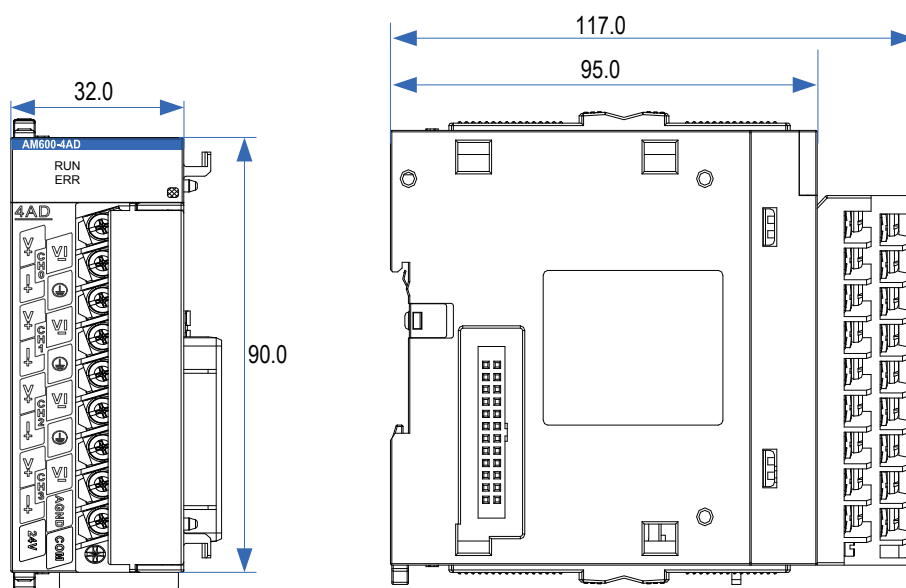

Figure 3-18 Dimensions of AI module(AM600-4AD)

3.4.4 AO Module

A 4 analog output module (AM600-4DA/GL10-4DA) is provided.

1) Basic specifications

Item	AM600-4DA/GL10-4DA
Output channels	4
Power supply voltage	24 VDC (20.4 VDC to 28.8 VDC) (-15% to +20%)
Power consumption of the internal 5 V power supply	85 mA (typical value)
Voltage output load	1 k Ω to 1 M Ω
Current load impedance	0 Ω to 600 Ω
Output voltage range	Bipolar: ± 5 V, ± 10 V; Unipolar: +5 V, +10 V
Output current range	4 mA to 20 mA, 0 mA to 20 mA
Accuracy (normal temperature: 25°C)	Voltage: $\pm 0.1\%$, current: $\pm 0.1\%$ (full ranges)
Accuracy (ambient temperature: 0°C to 55°C)	Voltage: $\pm 0.15\%$, current: $\pm 0.8\%$ (full ranges)
Resolution	16 bits
Conversion time	1 ms/channel
Isolation method	Isolation between I/O terminals and power supply No isolation between channels
Output short-circuit protection	Yes
System program update mode	USB port
Isolation method	Isolation between I/O terminals and power supply
System program update mode	USB port

The relationship between the actual analog output and the digital values is as follows:

Output Type	Rated Output Range	Corresponding Digital Value Range	Output Limit Range	Corresponding Digital Value Range
Analog voltage output	-10 V to 10 V	-20,000 to 20,000	-11 V to 11 V	-22,000 to 22,000
	0 V to +10 V	0 to 20000	-0.5 V to 10.5 V	-1000 to +21,000
	-5 V to 5 V	-20,000 to 20,000	-5.5 V to 5.5 V	-22,000 to 22,000
	0 V to 5 V	0 to 20000	-0.25 V to 5.25 V	-1000 to +21,000
	1 V to 5 V	0 to 20000	0.8 V to 5.2 V	-1000 to +21,000
Analog current output	0 mA to 20 mA	0 to 20000	0 mA to 21 mA	0 to 21,000
	4 mA to 20 mA	0 to 20000	3.2 mA to 20.8 mA	-1000 to +21,000

2) Module interfaces description

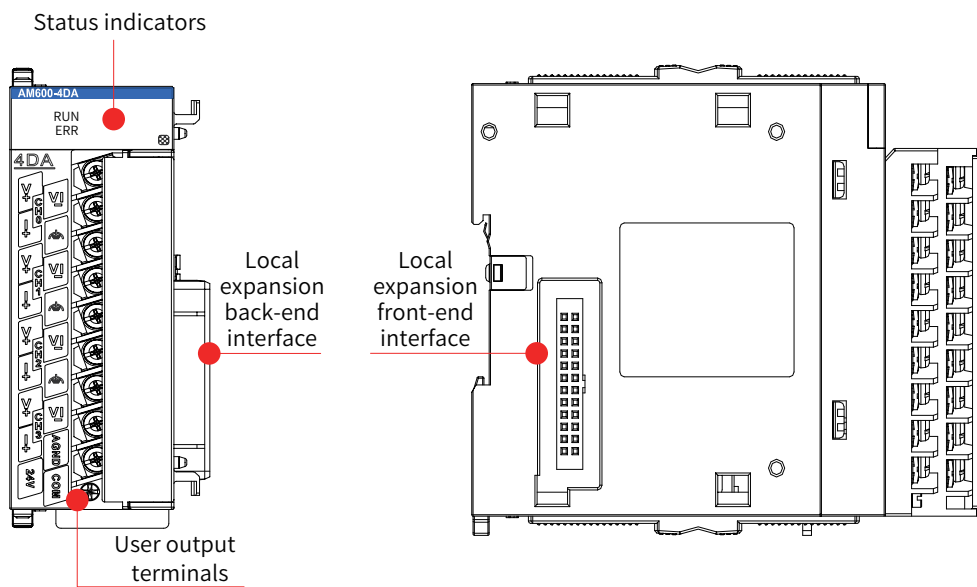

Figure 3-19 Interfaces of the AO module(AM600-4DA)

Interface Name	Function
User output terminals	4-channel output (Voltage and current output supported. For details about the use, see " Chapter 5 Wiring ".)
Status indicators	RUN: operation state indicator, which is on during normal operation and off when a fault occurs. ERR: error state indicator, which is on when a fault occurs.
Local expansion module back-end interface	Connects to the backward module and does not support hot swap. For details about the use, see " Chapter 4 Installation ".
Local expansion module front-end interface	Connects to the forward module and does not support hot swap. For details about the use, see " Chapter 4 Installation ".

3) Dimensions (mm)

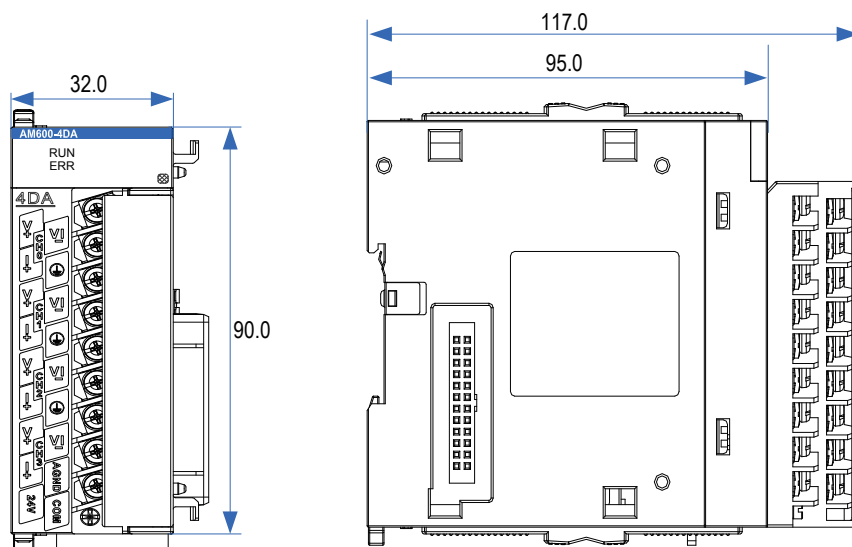

Figure 3-20 Dimensions of AO module(AM600-4DA)

3.4.5 Temperature Detection Modules

3 different temperature detection modules (AM600-4PT/GL10-4PT, AM600-4TC/GL10-4TC, AM600-8TC/GL10-8TC) are provided.

1) Basic specifications

■ General specifications

AM600-4PT/GL10-4PT		AM600-4TC/GL10-4TC		AM600-8TC/GL10-8TC	
Item	Specifications		Specifications		Specifications
Input channels	4		4		8
Power supply voltage	24 VDC (20.4 VDC to 28.8 VDC) (-15% to +20%)				
Power consumption of the internal 5 V power supply	85 mA (typical value)				
Sensor type	Thermal resistor: Pt100, Pt500, Pt1000, and Cu100		Thermocouple: B, E, J, K, N, R, S, and T		Thermocouple: B, E, J, K, N, R, S, and T
Display mode	Celsius degree (°C), and Fahrenheit degree (°F)				
Wiring mode	Thermal resistor wiring, two wires/three wires		Thermocouple wiring, two wires (Thermocouple cold-side compensation mode: Internal/external cold-side compensation. AM600-4TC is not capable of external cold-side compensation.)		Thermocouple wiring, two wires (Thermocouple cold-side compensation mode: Internal/external cold-side compensation)
Resolution	24 bits				
Sensitivity	0.1°C or 0.1 °F				
Sampling cycle	250 ms, 500 ms, or 1000 ms (The sampling cycles of the four channels can be set separately using software.)				250 ms, 500 ms, or 1000 ms (The sampling cycles of the eight channels can be set separately using software.)
Filter time	0s to 100s (The filter time can be set using software.)				
Accuracy	Normal temperature: 25°C , full scale x (±0.3%)		Normal temperature: 25°C , full scale x (±0.1%) + 1°C		
Accuracy	Ambient temperature: 0°C to 55°C , full scale x (±1%)		Ambient temperature: 0°C to 55°C , full scale x (±0.3%) + 1 °C		
Isolation method	Isolation between I/O terminals and power supply Isolation between channels				
System program update mode	USB port				
Diagnosis and protection	Supports limit excess and wire disconnecting diagnosis.				

■ Specifications in detecting mode

AM600-4PT (thermal resistor type)			AM600-4TC (thermocouple type)			AM600-8TC (thermocouple type)		
Sensor Name	Celsius Temperature Range (°C)	Fahrenheit Temperature Range (°F)	Sensor Name	Celsius Temperature Range (°C)	Fahrenheit Temperature Range (°F)	Sensor Name	Celsius Temperature Range (°C)	Fahrenheit Temperature Range (°F)
Pt100	-200.0 to 850.0	-328.0 to 1562.0	B	200.0 to 1800.0	392.0 to 3272.0	B	250.0 to 1820.0	482.0 to 3308.0
Pt500	-200.0 to 850.0	-328.0 to 1562.0	E	-270.0 to 1000.0	-454.0 to 1832.0	E	-270.0 to 1000.0	-454.0 to 1832.0
Pt1000	-200.0 to 850.0	-328.0 to 1562.0	N	-200.0 to 1300.0	-328.0 to 2372.0	N	-200.0 to 1300.0	-328.0 to 2372.0
Cu100	-50.0 to 150.0	-58.0 to 302.0	J	-210.0 to 1200.0	-346.0 to 2192.0	J	-210.0 to 1200.0	-346.0 to 2192.0

AM600-4PT (thermal resistor type)			AM600-4TC (thermocouple type)			AM600-8TC (thermocouple type)		
Sensor Name	Celsius Temperature Range (°C)	Fahrenheit Temperature Range (°F)	Sensor Name	Celsius Temperature Range (°C)	Fahrenheit Temperature Range (°F)	Sensor Name	Celsius Temperature Range (°C)	Fahrenheit Temperature Range (°F)
			K	-270.0 to 1370.0	-454.0 to 2498.0	K	-270.0 to 1372.0	-454.0 to 2502.0
			R	-50.0 to 1765.0	-58.0 to 3209.0	R	-50.0 to 1768.0	-58.0 to 3214.0
			S	-50.0 to 1765.0	-58.0 to 3209.0	S	-50.0 to 1768.0	-58.0 to 3214.0
			T	-270.0 to 400.0	-454.0 to 752.0	T	-270.0 to 400.0	-454.0 to 752.0

2) Modules interfaces description

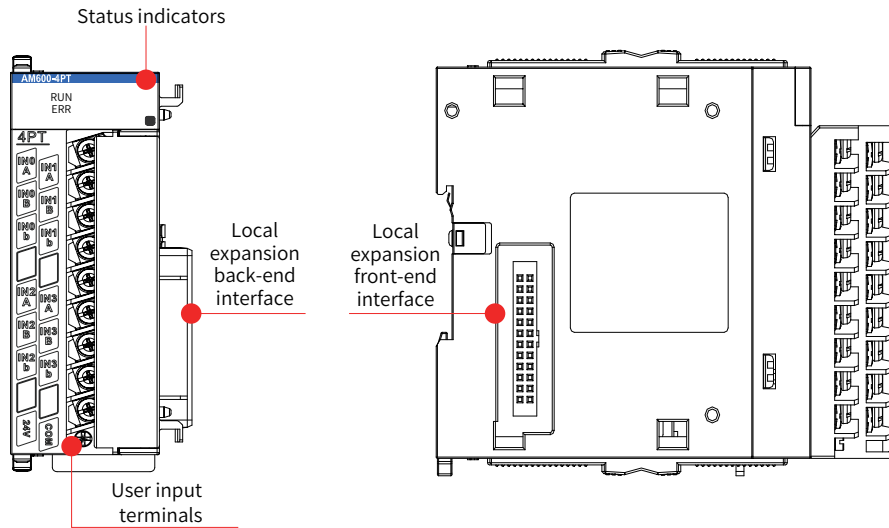

Figure 3-21 Interfaces of the temperature detection modules

3) Dimensions (mm)

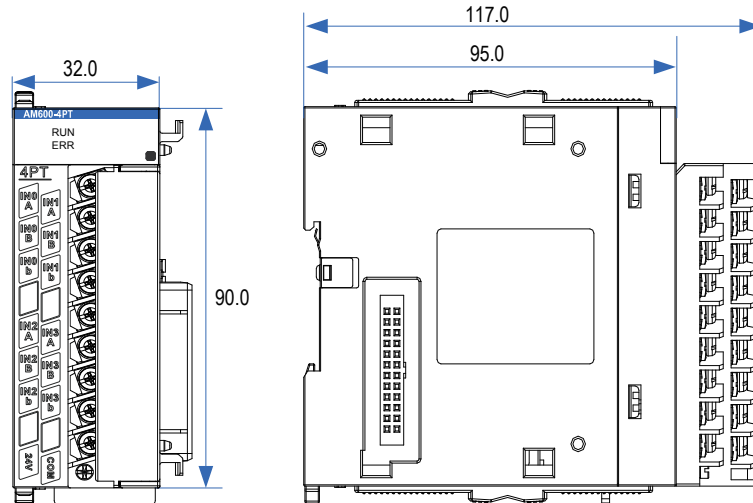

Figure 3-22 Dimensions of the temperature detection modules

3.5 Remote Expansion Modules (EtherCAT)

3.5.1 EtherCAT Communication Modules

Two interface modules (AM600-RTU-ECT and AM600-RTU-ECTA/GL10-RTU-ECTA) that support EtherCAT communication are provided. The AM600-RTU-ECTA module supports automatic scan. The detailed specifications are as follows:

1) Basic specifications

Item	Specifications
Power supply voltage	24 VDC (20.4 VDC to 28.8 VDC) (-15% to +20%), which can be connected from an external power supply.
Protocol for communication with CPU module	EtherCAT, 100 Mbit/s network speed
EtherCAT communication baud rate	Maximum 100 Mbit/s to support the EtherCAT communication baud rate of the master station
Network port/network cable	Standard Ethernet interface and standard Ethernet cable (Cat5e network cable)
Station number range	1 to 125. The internal address is automatically arranged in the network bus connection sequence.
Expandability of subsequent I/O modules	A maximum of 16 I/O expansion modules can be connected. The number and configuration vary depending on power consumption of the modules.

The following table lists the performance indicators:

Item	Specifications
Communication protocol	EtherCAT
Services supported	CoE (PDO, SDO)
Minimum synchronization period of 6-axis cam	1250 μ s (TYP)
Synchronization mode	The servo uses a DC distributed clock. I/O uses I/O synchronization.
Physical layer	100BASE-TX
Baud rate	100 Mbit/s (100Base-TX)
Duplex mode	Full duplex
Topological structure	Linear topological structure
Transmission medium	For the network cable, see " Chapter 5 Wiring ".
Transmission distance	Less than 100 M between two nodes
Number of slaves	The maximum number of slave stations is 125.
EtherCAT frame length	44 bytes to 1498 bytes
Process data	A single Ethernet frame contains a maximum of 1486 bytes.
Synchronization jitter of two slaves	< 1 μ s
Refresh time	1000 digital inputs and outputs: approximately 30 μ s; 32 servo axes: approximately 100 μ s

2) Modules interfaces description

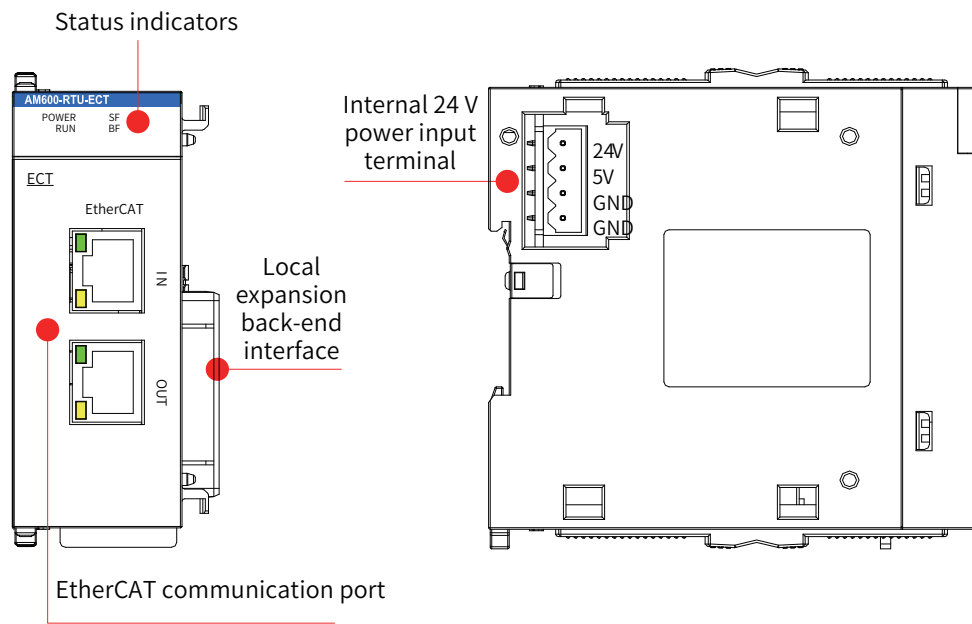

Figure 3-23 Interfaces of EtherCAT communication modules (AM600-RTU-ECT/AM600-RTU-ECTA)

No.	Interface Name	Function
1	IN	EtherCAT input interface
	OUT	EtherCAT output interface
2	Status indicators	POWER: power indicator RUN: running indicator SF: expansion bus error indicator BF: communication error indicator
3	Local expansion module back-end interface	Connects to the back-end module and does not support hot swap. For details about the use, see " Chapter 4 Installation ".
4	Internal 24 V power input terminal	Connects to the power module and does not support hot swap. For details about the use, see " Chapter 4 Installation ".

3) Dimensions (mm)

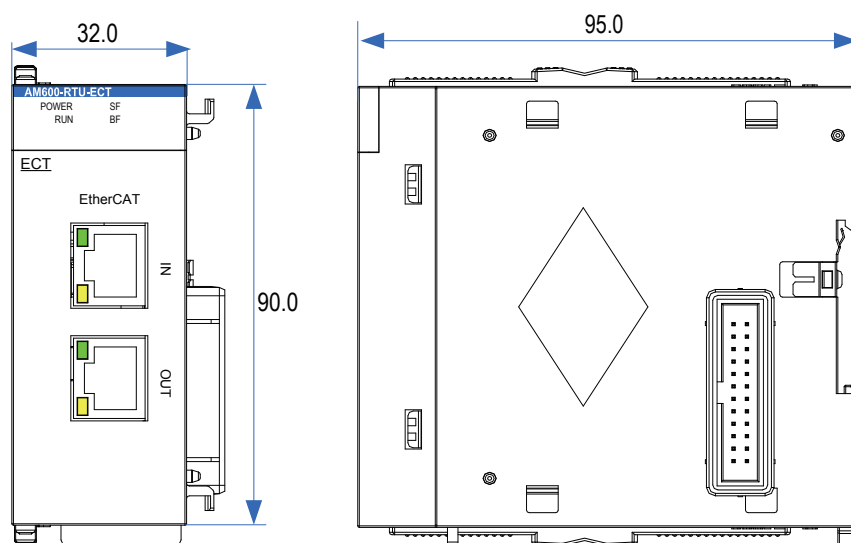

Figure 3-24 Dimensions of EtherCAT communication modules (AM600-RTU-ECT/AM600-RTU-ECTA)

3.5.2 I/O Modules

Two I/O modules (AM600-0808ETNE/GR10-0808ETNE and AM600-1616ETNE/GR10-1616ETNE) that support EtherCAT remote communication are provided. The detailed specifications are as follows:

1) Basic specifications

Item	Specifications
Power specifications	24 VDC (20.4 VDC to 28.8 VDC) (-15% to +20%)
Communication protocol	EtherCAT industrial real-time bus protocol
Max. communication baud rate	100 Mbps
Network port/network cable	Standard network ports with Cat5e network cables shorter than 100 m
Station number range	Set the DIP switch between 1 and 255 or use the value automatically assigned by the network bus.

■ The following table lists the performance indicators:

Item	Specifications
Communication protocol	EtherCAT
Services supported	CoE (PDO, SDO) and FoE
Synchronization mode	I/O uses a DC-distributed clock or I/O synchronization.
Physical layer	100BASE-TX
Baud rate	100 Mbit/s (100Base-TX)
Duplex mode	Full duplex
Topological structure	Linear topological structure
Transmission medium	For the network cable, see " Chapter 5 Wiring ".
Transmission distance	Less than 100 M between two nodes
EtherCAT frame length	44 bytes to 1498 bytes
Process data	A single frame can contain a maximum of 1486 bytes.
Synchronization jitter of two slaves	< 1 μs
Refresh time	1000 digital inputs and outputs: approximately 30 μs; 32 servo axes: approximately 100 μs

2) Modules interfaces description

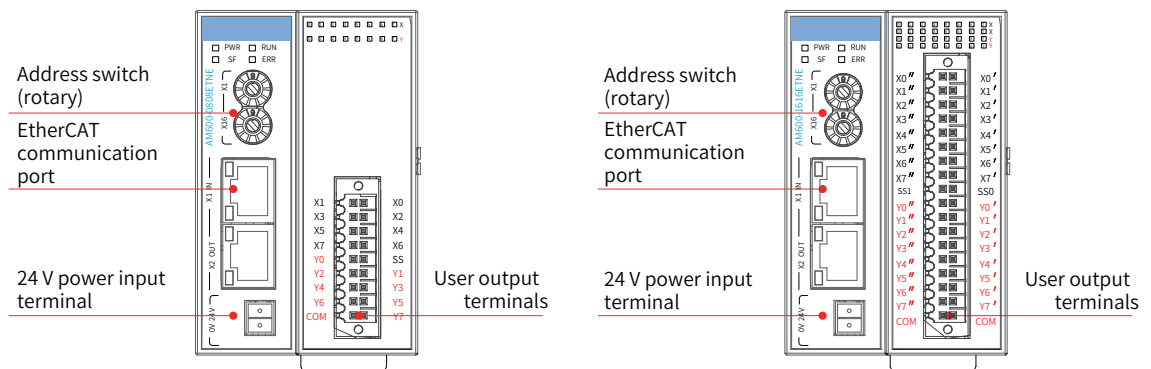

Figure 3-25 Modules interfaces

Interface Name	Function			
EtherCAT communication port	X1 IN: EtherCAT input interface			
	X2 OUT: EtherCAT output interface that connects to the back-end EtherCAT slave station			
Signal indicators	PWR	Power indicator	Green	On when the power is switched on
	RUN	Running indicator	Green	On when the module is running normally
	SF	Module fault indicator	Red	On when the module is faulty
	ERR	State machine error indicator	Red	On when a state machine error occurs

Interface Name	Function
I/O signal indicator	I/O status indicator: ON: I/O active OFF: I/O inactive
24 V power input terminal	Module power input
Address switch (rotary switch)	Sets the slave station address: ADDR1/ADDR0: station address DIP switch. The address is set in the hexadecimal format. Slave station decimal address = ADDR1 x 16 + ADDR0 x 1 (address range: 1 to 255)
User output terminal	For the definition, see " Chapter 5 Wiring ".

3) Modules dimensions

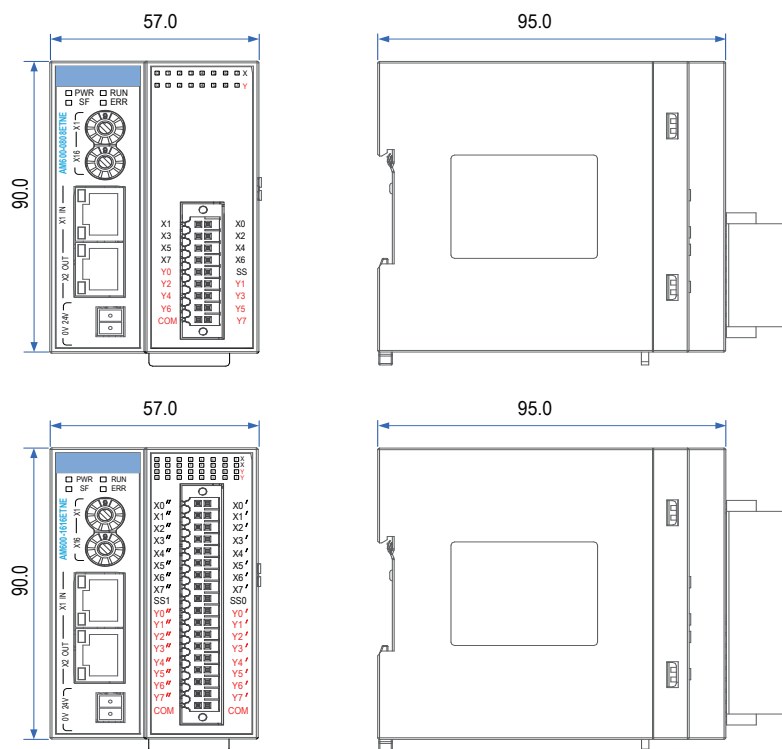

Figure 3-26 Modules installation dimensions (mm)

3.5.3 High-speed Counting Module

A counting module (AM600-2HCE/GR10-2HCE) that supports EtherCAT remote communication is provided. The specifications are as follows:

1) Basic specifications

Item	Specifications
Power supply voltage	24 VDC (20.4 VDC to 28.8 VDC) (-15% to +20%), which can be connected from an external power supply.
Protocol for communication with CPU module	EtherCAT, 100 Mbit/s network speed
EtherCAT communication baud rate	Maximum 100 Mbit/s to support the EtherCAT communication baud rate of the master station
Network port/network cable	Standard Ethernet port and standard Ethernet cable (Cat5e network cable)
Station number range	1 to 255. The internal address is automatically arranged in the network bus connection sequence.

■ The following table lists the performance indicators:

Item	Specifications
Communication protocol	EtherCAT
Services supported	CoE (PDO, SDO) and FoE
Minimum synchronization period of 6-axis cam	1250 μs (TYP)
Synchronization mode	The servo uses a DC distributed clock. I/O uses I/O synchronization.
Physical layer	100BASE-TX
Baud rate	100 Mbit/s (100Base-TX)
Duplex mode	Full duplex
Topological structure	Linear topological structure
Transmission medium	For the network cable, see the " Chapter 5 Wiring ".
Transmission distance	Less than 100 M between two nodes
EtherCAT frame length	44 bytes to 1498 bytes
Process data	A single Ethernet frame contains a maximum of 1486 bytes.
Synchronization jitter of two slaves	< 1 μs
Refresh time	1000 digital inputs and outputs: approximately 30 μs; 32 servo axes: approximately 100 μs

2) Module interfaces description

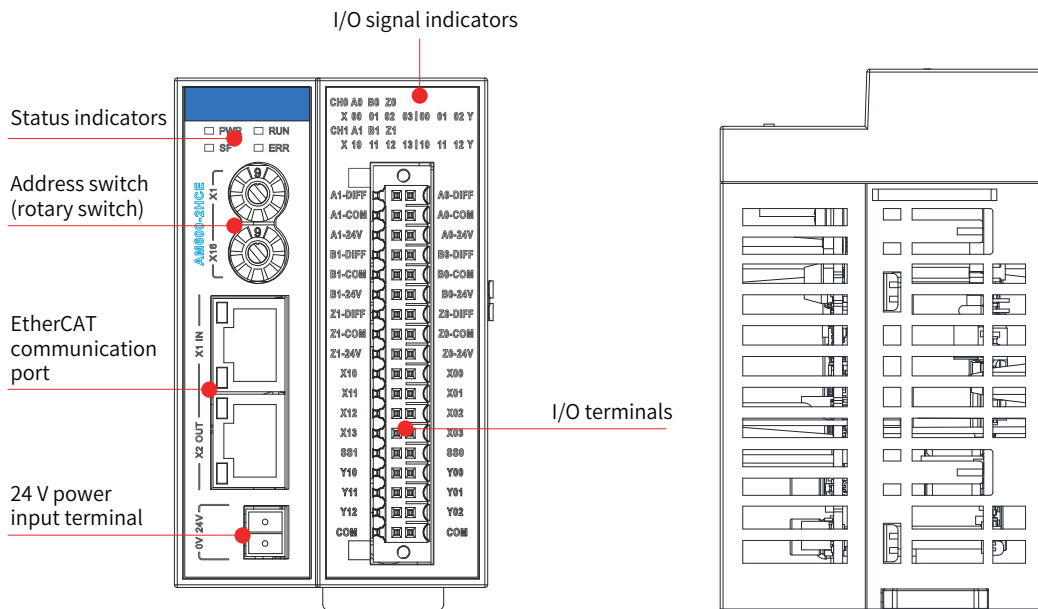

Figure 3-27 High-speeded counting module interfaces

Interface Name	Function			
EtherCAT communication port	X1 IN: EtherCAT input interface			
	X2 OUT: EtherCAT output port that connects to the back-end EtherCAT slave station			
Status indicators	PWR	Power indicator	Green	On when the power is switched on
	RUN	Running indicator	Green	On when the module is running normally
	SF	Module fault indicator	Red	On when the module is faulty
	ERR	State machine error indicator	Red	On when a state machine error occurs
I/O signal indicators	I/O status indicator: ON: I/O active OFF: I/O inactive			
24 V power input terminal	Module power input			
Address switch (rotary switch)	Sets the slave station address: ADDR1/ADDR0: station address DIP switch. The address is set in the hexadecimal format. Slave station decimal address = ADDR1 x 16 + ADDR0 x 1 (address range: 1 to 255)			
User output terminal	For the definition, see " Chapter 5 Wiring ".			

3) AM600-2HCE high-speed counting module dimensions (mm)

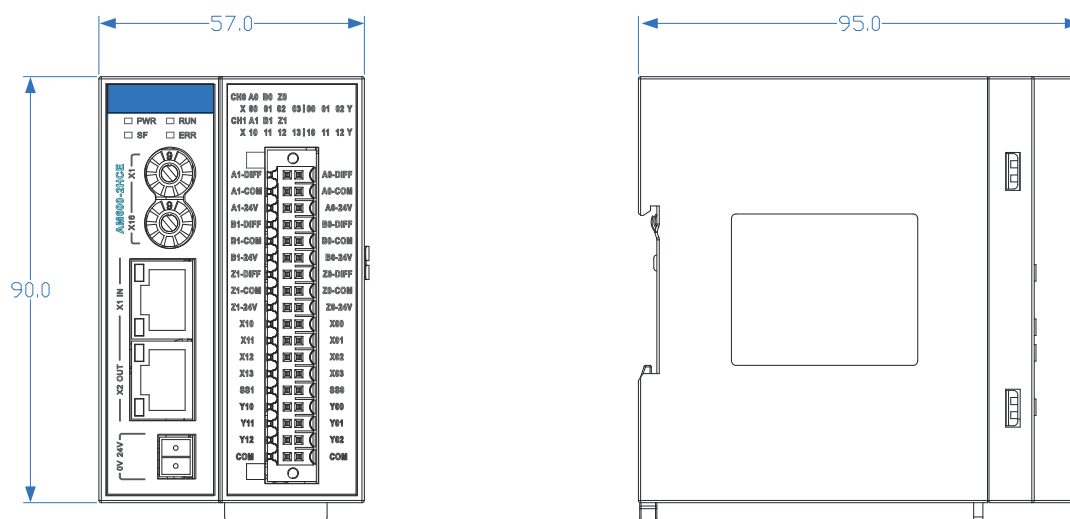

Figure 3-28 Dimensions of the high-speed counting module

3.5.4 Positioning Module

A remote positioning module (AM600-4PME/GR10-4PME) that supports EtherCAT remote communication is provided. The specifications are as follows:

1) Specifications

Item	Specifications
Power supply voltage	24 VDC (20.4 VDC to 28.8 VDC) (-15% to +20%), which can be connected from an external power supply.
Protocol for communication with CPU module	EtherCAT, 100 Mbit/s network speed
EtherCAT communication baud rate	Maximum 100 Mbit/s to support the EtherCAT communication baud rate of the master station
Network port/network cable	Standard Ethernet port and standard Ethernet cable (Cat5e network cable)
Station number range	1 to 255. The internal address is automatically arranged in the network bus connection sequence.

■ The following table lists the performance indicators:

Item	Specifications
Communication protocol	EtherCAT
Services supported	CoE (PDO, SDO) and FoE
Minimum synchronization period of 4-axis cam	1 ms (TYP)
Synchronization mode	The servo uses a DC distributed clock. I/O uses I/O synchronization.
Physical layer	100BASE-TX
Baud rate	100 Mbit/s (100Base-TX)
Duplex mode	Full duplex
Topological structure	Linear topological structure
Transmission medium	For the network cable, see the " Chapter 5 Wiring ".
Transmission distance	Less than 100 M between two nodes
EtherCAT frame length	44 bytes to 1498 bytes
Process data	A single Ethernet frame contains a maximum of 1486 bytes.
Synchronization jitter of two slaves	< 1 μs
Refresh time	1000 digital inputs and outputs: approximately 30 μs; 32 servo axes: approximately 100 μs

2) Module interfaces description

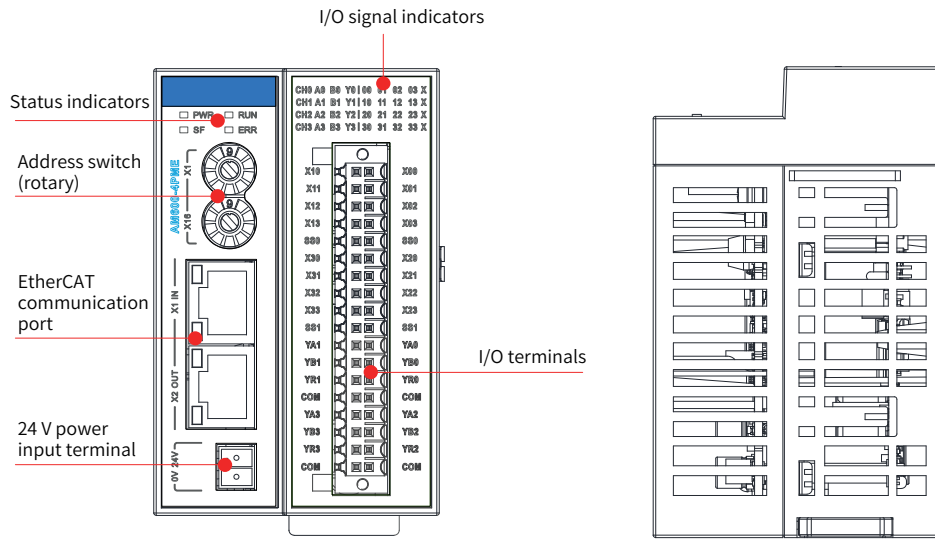
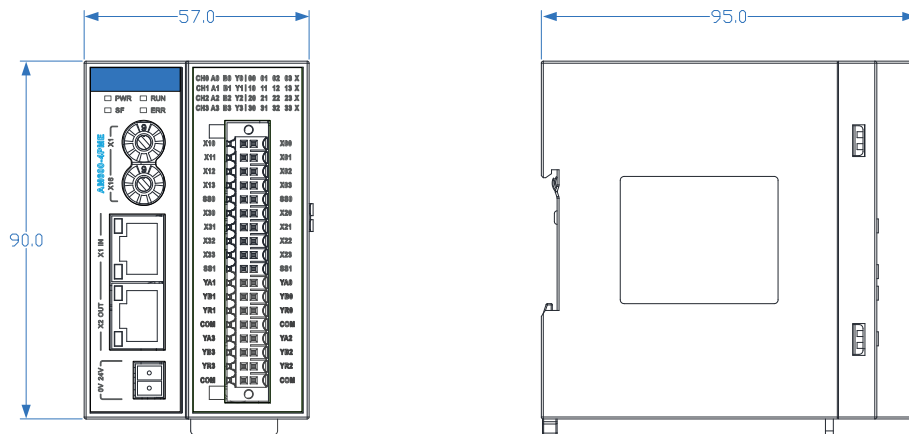

Figure 3-29 Positioning module interfaces

Interface Name	Function			
EtherCAT communication port	X1 IN: EtherCAT input interface			
	X2 OUT: EtherCAT output interface that connects to the back-end EtherCAT slave station			
Status indicators	PWR	Power indicator	Green	On when the power is switched on
	RUN	Running indicator	Green	On when the module is running normally
	SF	Module fault indicator	Red	On when the module is faulty
	ERR	State machine error indicator	Red	On when a state machine error occurs
I/O signal indicators	Corresponds to various I/O signals. ON: I/O active OFF: I/O inactive			
24 V power input terminal	Module power input			
Address switch (rotary switch)	Sets the slave station address: ADDR1/ADDR0: station address DIP switch. The address is set in the hexadecimal format. Slave station decimal address = ADDR1 x 16 + ADDR0 x 1 (address range: 1 to 255)			
User output terminal	For the definition, see "Chapter 5 Wiring" .			

3) AM600-4PME positioning module dimensions (mm)



3.6 Remote Expansion Module (PROFIBUS-DP)

A remote expansion module (AM600-RTU-DP) with PROFIBUS-DP communication interface is provided.

1) Basic specifications

Item	Specifications
Power supply voltage	24 VDC (20.4 VDC to 28.8 VDC) (-15% to +20%), which can be connected from an external power supply.
Output current of the internal 5 V power supply	1200 mA (rated)
Protocol for communication with CPU module	PROFIBUS-DP Maximum baud rate: 12 Mbps
PROFIBUS-DP communication baud rate	9.6 Kbps to 12 Mbps. The speed automatically adapts to that of the PROFIBUS-DP master station.
Station number range	The PROFIBUS-DP station number ranges from 1 to 125, the maximum number of connectable stations is 31. You can use the DIP switch to set the station number.
Expandability of subsequent I/O expansion modules	A maximum of 16 I/O expansion modules can be connected. The number and configuration vary depending on power consumption of the modules.
PROFIBUS-DP Network port	One DB9 female connector interface

2) Module interfaces description

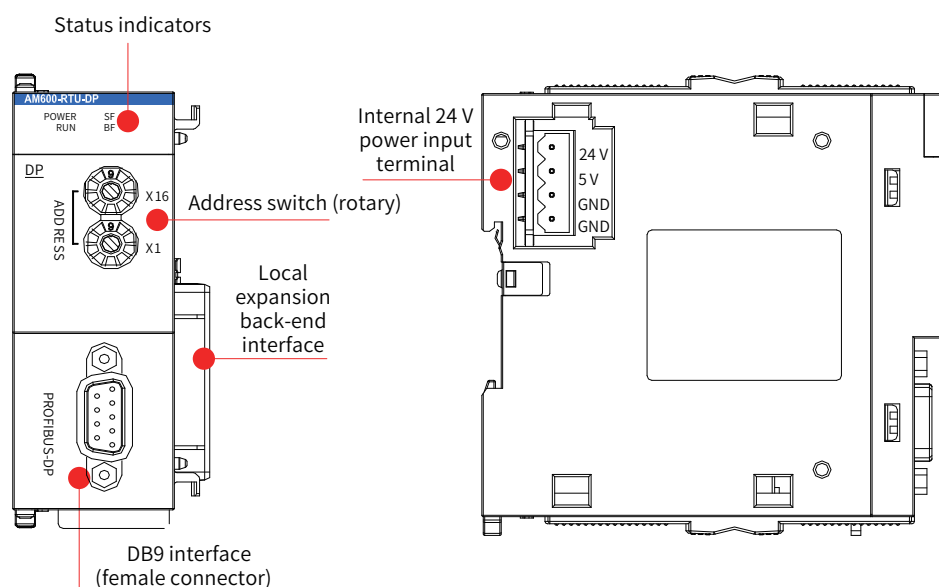

Figure 3-30 PROFIBUS-DP module interfaces

Interface Name	Function			
DB9 interface	PROFIBUS-DP communication port			
Address switch (rotary switch)	ADDR1	The station address is set with a 16-bit DIP switch. Decimal slave station address = ADDR1 x 16 + ADDR0 (address range: 1 to 125). For details about the use, see "Chapter 5 Wiring" .		
	ADDR0	Note: The number of values that a DIP switch can set is 153 (9 x 16 + 9 x 1). The PROFIBUS-DP station number range is 1 to 125. Therefore, you need to avoid using station numbers greater than 125.		
Status indicators	POWER	Power indicator	Green	On when the power is switched on
	SF	Slave station configuration error indicator	Red	On when a configuration error of the slave station expansion module occurs
	BF	Slave station expansion bus error indicator	Red	Blinks when an error of the slave station expansion bus occurs

Interface Name	Function
Local expansion module back-end interface	Connects to the back-end module and does not support hot swap. For details about the use, see " Chapter 4 Installation ".
Internal 24 V power input terminal	Connects to the power module and does not support hot swap. For details about the use, see " Chapter 4 Installation ".

3) Dimensions (mm)

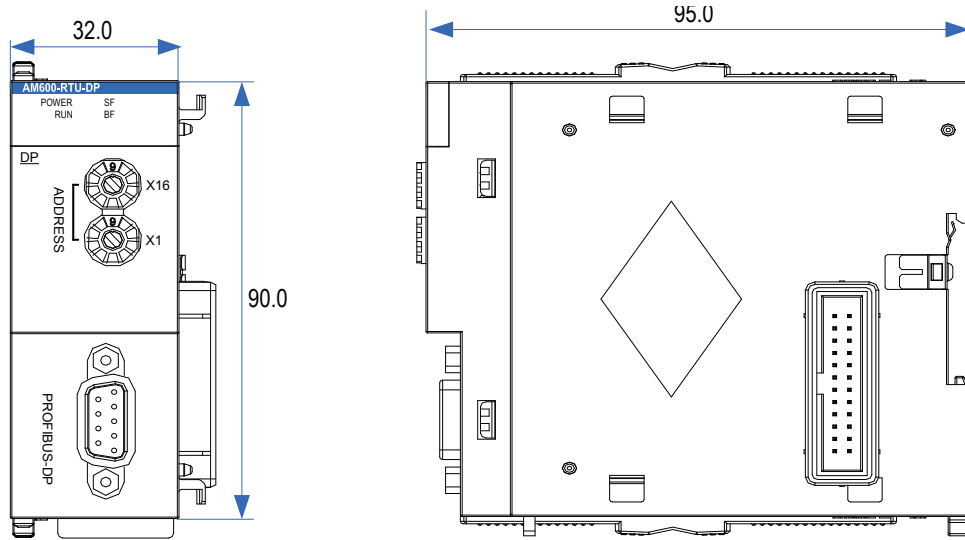

Figure 3-31 Dimensions of the PROFIBUS-DP module

3.7 Remote Expansion Module (CANopen)

A remote expansion module (AM600-RTU-COP/GL10-RTU-COP) with CANopen communication interface is provided.

1) Basic specifications

Item	Specifications
Power specifications	24 VDC (20.4 VDC to 28.8 VDC) (-15% to +20%)
Output current of the internal 5 V power supply	1200 mA (rated)
Protocol for communication with CPU module	CANopen
CANopen communication rate	10 Kbps, 20 Kbps, 50 Kbps, 125 Kbps, 250 Kbps, 500 Kbps, 800 Kbps, and 1 Mbps
Max. stations supported by CANopen network	63
Station number range	The CANopen station number ranges from 1 to 127. The maximum number of connectable stations is 63.
Expandability of subsequent I/O modules	A maximum of 16 I/O modules can be added. The number and configuration vary depending on power consumption of the modules.
CANopen network port	One DB9 male connector interface

2) Module interfaces description

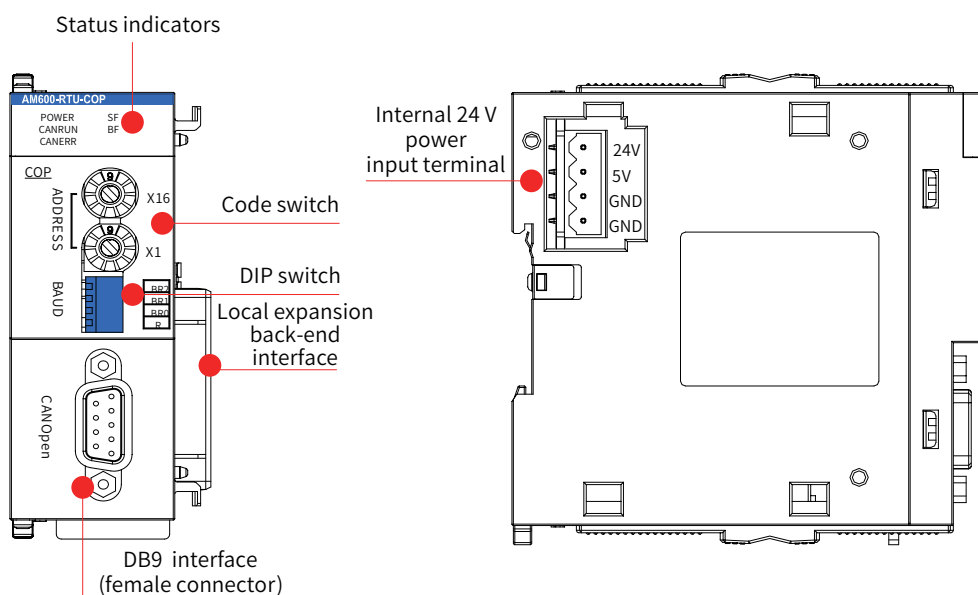

Figure 3-32 CANopen module interfaces

Interface Name	Function																					
DB9 interface	CANopen communication port																					
Address switch (rotary switch)	<p>This 16-bit rotary switch is used to set the station address. Decimal slave station address = ADDR1 x 16 + ADDR0 . For details about the use, see "Chapter 5 Wiring".</p> <p>Note: The maximum address that this switch can set is 153 (9 x 16 + 9 x 1). The CANopen station number range is 1 to 127. Therefore, you need to avoid using station numbers higher than 127.</p>																					
Baud rate selection switch (DIP switch)	<p>The DIP switch is used to set the baud rate.</p> <table border="1"> <thead> <tr> <th>Value of DIP Switch</th> <th>0</th> <th>1</th> <th>2</th> <th>3</th> <th>4</th> <th>5</th> <th>6</th> <th>7</th> </tr> </thead> <tbody> <tr> <th>Baud Rate (bps)</th> <td>1 M</td> <td>800 K</td> <td>500 K</td> <td>250 K</td> <td>125 K</td> <td>50 K</td> <td>20 K</td> <td>10 K</td> </tr> </tbody> </table>				Value of DIP Switch	0	1	2	3	4	5	6	7	Baud Rate (bps)	1 M	800 K	500 K	250 K	125 K	50 K	20 K	10 K
Value of DIP Switch	0	1	2	3	4	5	6	7														
Baud Rate (bps)	1 M	800 K	500 K	250 K	125 K	50 K	20 K	10 K														
Status indicators	POWER	Power indicator	Green	On when the power is switched on																		
	CANRUN	CAN bus running indicator	Green	On when the module is running normally																		
	CANERR	CAN bus error indicator	Red	On when a CAN bus error occurs																		
	SF	Slave station configuration error indicator	Red	On when a configuration error of the slave station expansion module occurs																		
	BF	Slave station expansion bus error indicator	Red	Blinks when an error of the slave station expansion module occurs																		
Local expansion module back-end interface	Connects to the backward module and does not support hot swap. For details about the use, see " Chapter 4 Installation ".																					
Internal 24 V power input terminal	Connects to the power module and does not support hot swap. For details about the use, see " Chapter 4 Installation ".																					

3) Dimensions (mm)

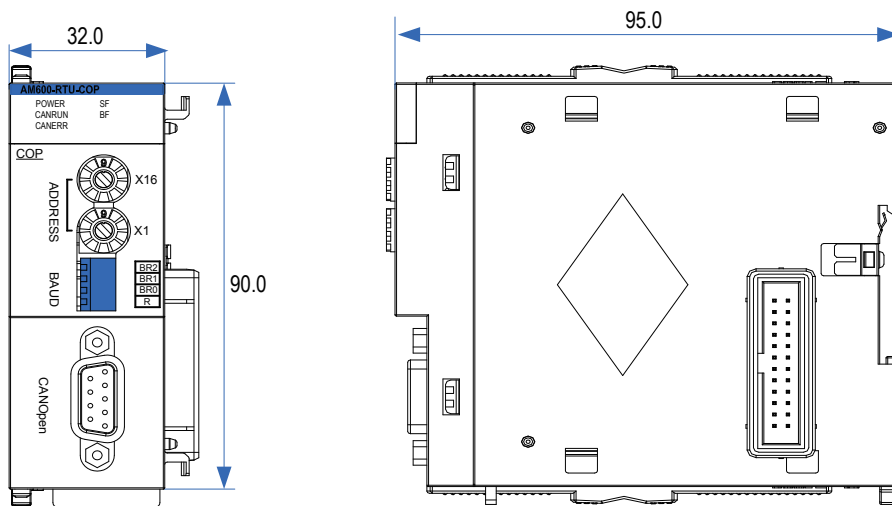

Figure 3-33 Dimensions of the CANopen module



Chapter 4 Installation

4.1 Installation Environment Requirements	56
4.1.1 Installation Environment	56
4.1.2 Installation Clearance	56
4.1.3 Installation Instructions	56
4.2 Installation Method	57
4.2.1 Module Installation Process	57
4.2.2 Mounting the DIN Guide Rail to the Installation Plane in the Control Cabinet.....	57
4.2.3 Connecting the Power Module, CPU Module, and Expansion Module.....	58
4.2.4 Mounting the Connected Module Group to the Guide Rail	59
4.2.5 Installing the System Protection Component - Tail Board	61
4.3 Installing and Removing the Terminal Block	61
4.4 Installing and Removing the SD Card	62
4.5 Replacing Modules.....	63

4.1 Installation Environment Requirements

4.1.1 Installation Environment

Consider operability, serviceability, environment endurance when installing the PLC on the guide rail. Do not install the module in the following environment:

- The ambient temperature is out of the range of -5 °C to 55 °C .
- The ambient humidity is out of the range of 5% to 95%.
- The temperature fluctuates dramatically, and moisture condensation occurs.
- Corrosive or combustible gases exist.
- A large amount of conductive powder such as dust and iron powder, oil mist, salt, or organic solvent exists.
- The module is exposed to direct sunlight.
- Strong electric field or magnetic field exists.
- The machine vibrates or is affected by passed-down impact.

4.1.2 Installation Clearance

To ensure good ventilation and simplify module replacement, reserve the clearance specified in the following figure between the modules, enclosure walls and components.

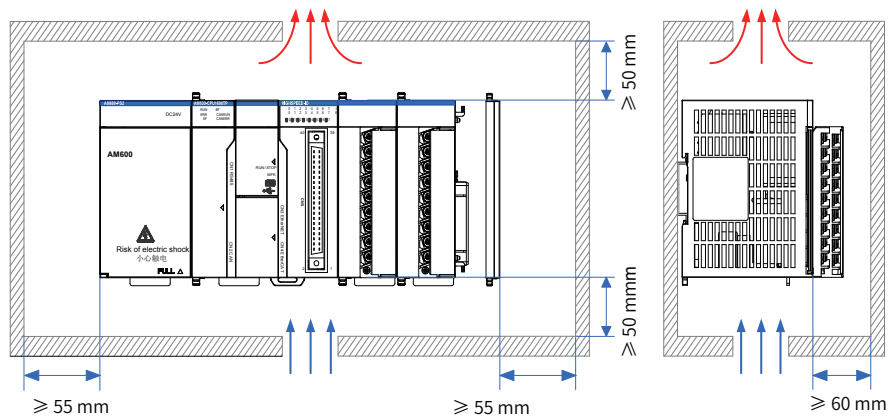

Figure 4-1 Installation clearance requirements

4.1.3 Installation Instructions

Comply with the following instructions during installation:

- Power off the product before installation.
- Avoid drop-off and impact of the housing, terminal block, and connector of the module to prevent damages.
- Do not disassemble the module.
- Do not tighten the machine with excessive torque to avoid damaging terminals.
- After installation and commissioning, remove the anti-dust label from the heat dissipation holes on the top of the module to ensure module reliability when the temperature rises.

4.2 Installation Method

4.2.1 Module Installation Process

Perform the following steps to install the module:

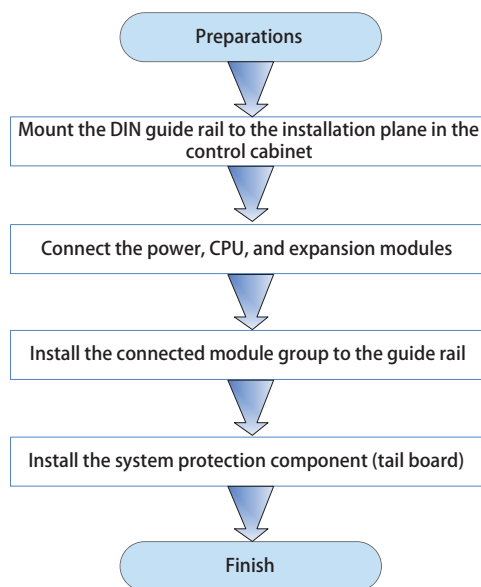

Figure 4-2 Installation procedure

4.2.2 Mounting the DIN Guide Rail to the Installation Plane in the Control Cabinet

You can prepare installation guide rails according to the DIN guide rail models (IEC 60715) in the following table:

Model	Length x Depth (mm)	Bolt Specifications
TH35-7.5Fe	35 × 7.5	M4
TH35-7.5Al	35 × 7.5	M4
TH35-15Fe	35 × 15	M4

To ensure DIN guide rail strength, fasten the installation bolts (prepared by the user) at an interval within 200 mm, starting from less than 30 mm from the guide rail end.

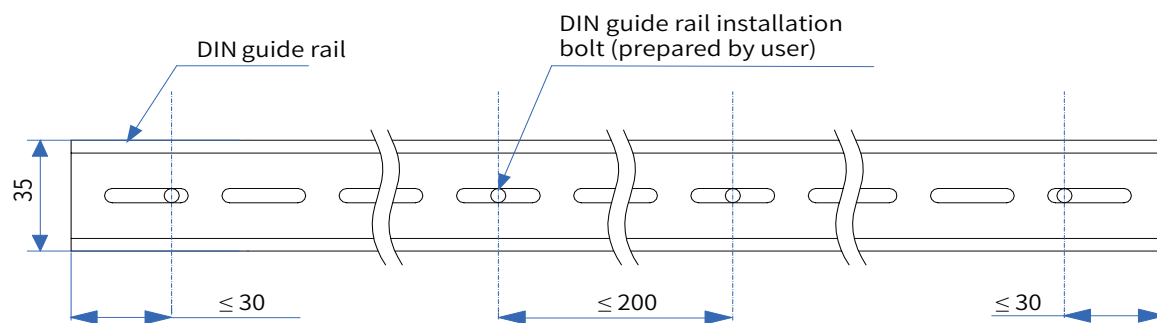

Figure 4-3 Bolt position requirements for DIN guide rail installation (mm)

Use M4 bolts to mount the DIN guide rail to the installation plane, as shown in the following figure:

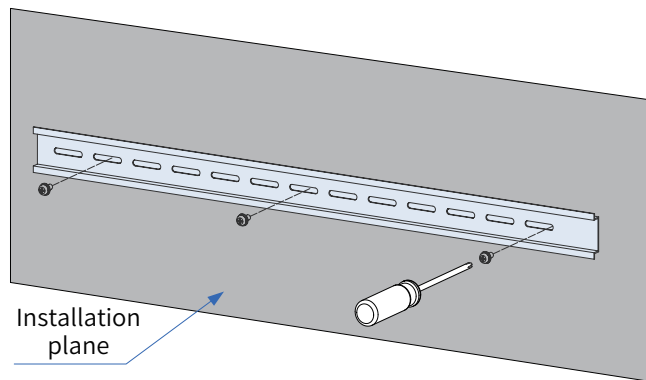

Figure 4-4 DIN guide rail installation

4.2.3 Connecting the Power Module, CPU Module, and Expansion Module

The modules are connected through the connectors and locks of the modules. Here the connection between the CPU module and the power module is used as an example.

- 1) Slide the lock on the CPU module as shown in the following figure.

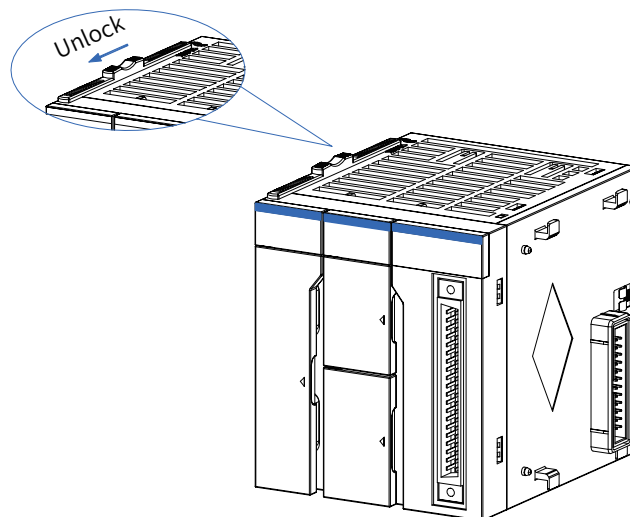

Figure 4-5 Slide in the shown direction to unlock

- 2) Connect the CPU module to the connector of the power module firmly.

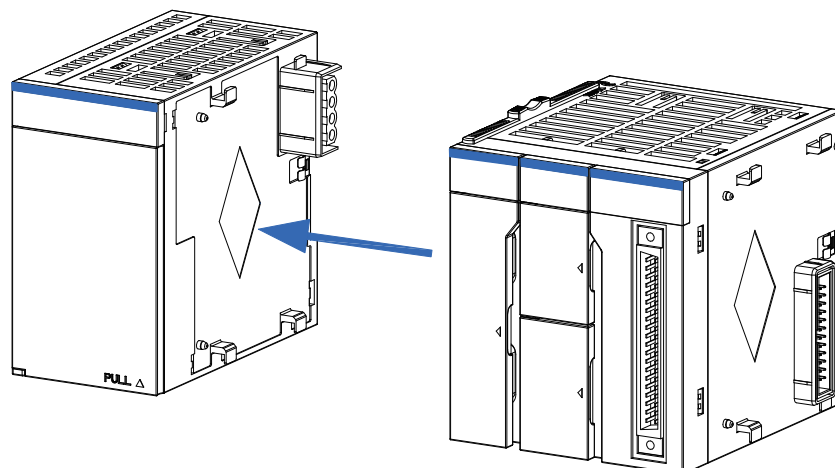

Figure 4-6 Connect to the connector of the power module

- 3) Slide the lock on the CPU module as shown in the following figure to lock the two modules.

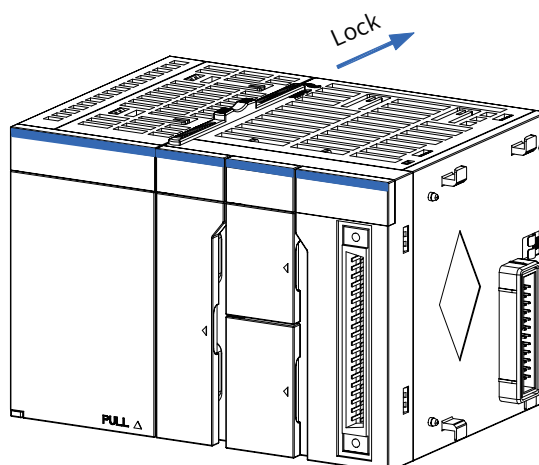

Figure 4-7 Slide in the shown direction to lock



CAUTION

- ◆ Check whether the connection is firm after the modules are locked together. If the module connection is not secured with the hooks, malfunction, fault, or drop-off may occur.
- ◆ If you need to disassemble the module, disconnect all the external power supplies from the module and perform the installation procedure in the reverse order.

4.2.4 Mounting the Connected Module Group to the Guide Rail

- 1) Pull out the DIN guide rail installation hooks (as shown in the following figure) on the rear side of the module until they click.

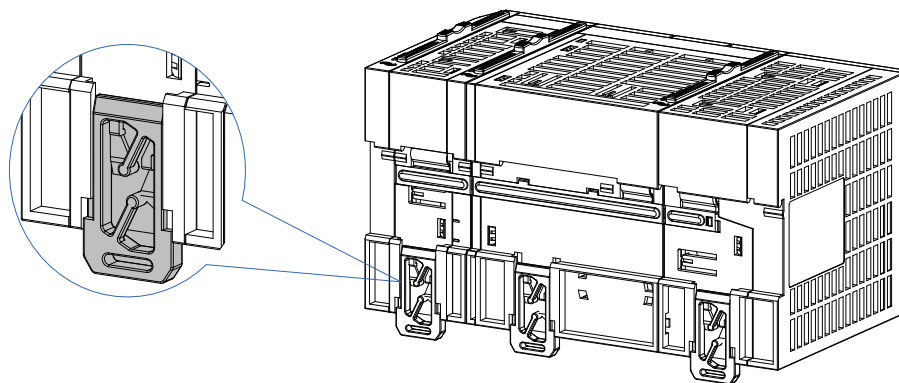

Figure 4-8 Pulling out the hooks

- 2) Put the fixing claws on the top of the module on the DIN guide rail and press the module down until it is plugged into the guide rail, as shown in A and B in the following figure.

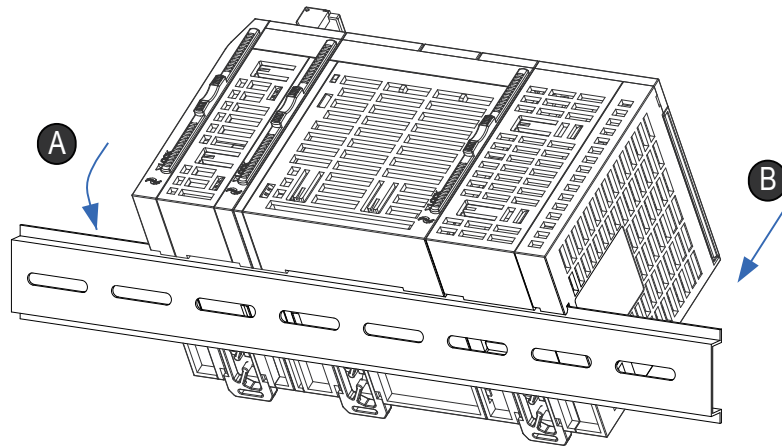

Figure 4-9 Plug the module into the DIN guide rail

- 3) Push up the DIN guide rail installation hooks of the module until they click to plug the module to the DIN guide rail. If your fingers cannot reach the DIN guide rail installation hooks, use a tool, for example, a screwdriver.

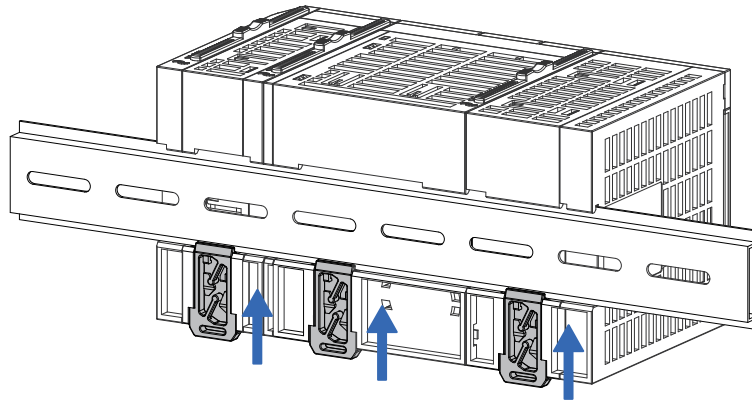
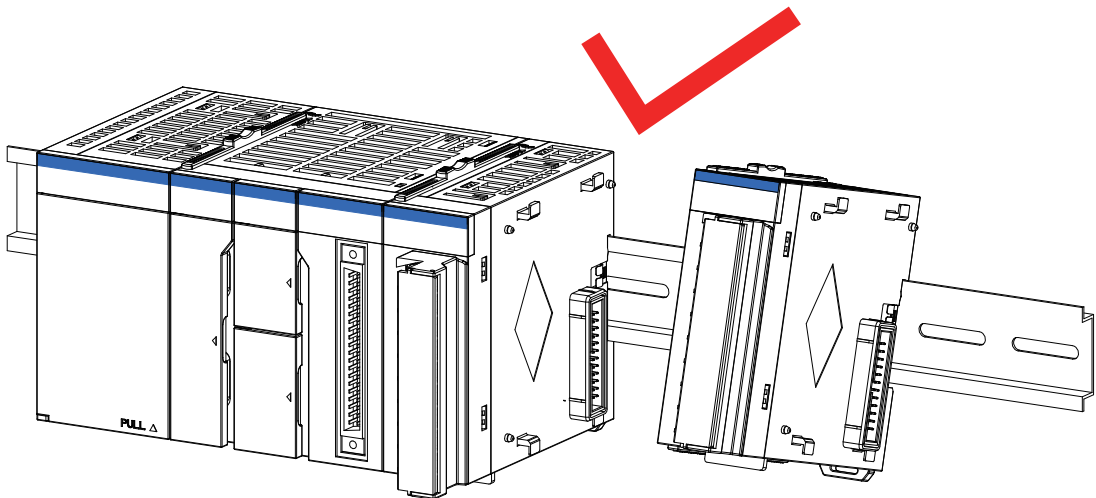

Figure 4-10 Plug in the hooks in the shown direction



◆ Do not install by sliding the module from the end of the DIN guide rail; otherwise, the metal parts on the rear side of the module may be damaged.



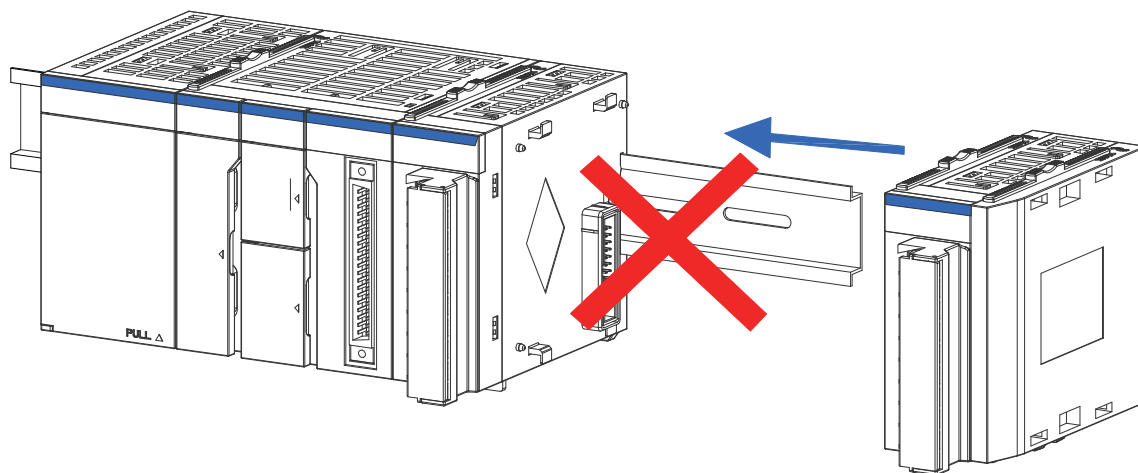

Figure 4-11 Correct and incorrect installation methods

4.2.5 Installing the System Protection Component - Tail Board

Modules of the AM600 series products are provided with front and rear connectors. To cover and protect the connector of the last module, a tail board is used.

4.3 Installing and Removing the Terminal Block

- 1) The procedure for removing the terminal block is as follows:
 - ① Open the terminal cover and unscrew the installation bolt of the terminal block.
 - ② Remove the terminal block from the end of the installation bolt.

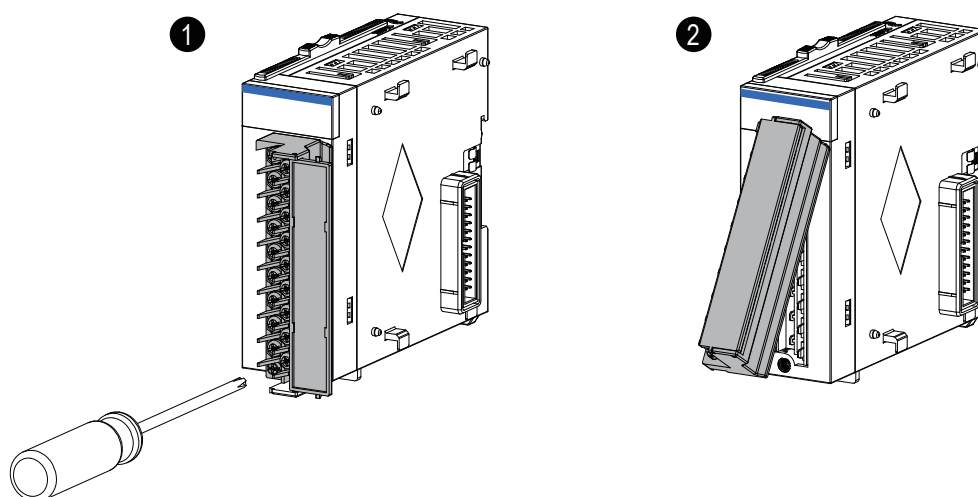

Figure 4-12 Removing the terminal block

2) Terminal block installation procedure

- ① Insert the protruding part into the terminal block mounting hole of the module and install the terminal block.
- ② Open the terminal cover and tighten the installation bolt of the terminal block.

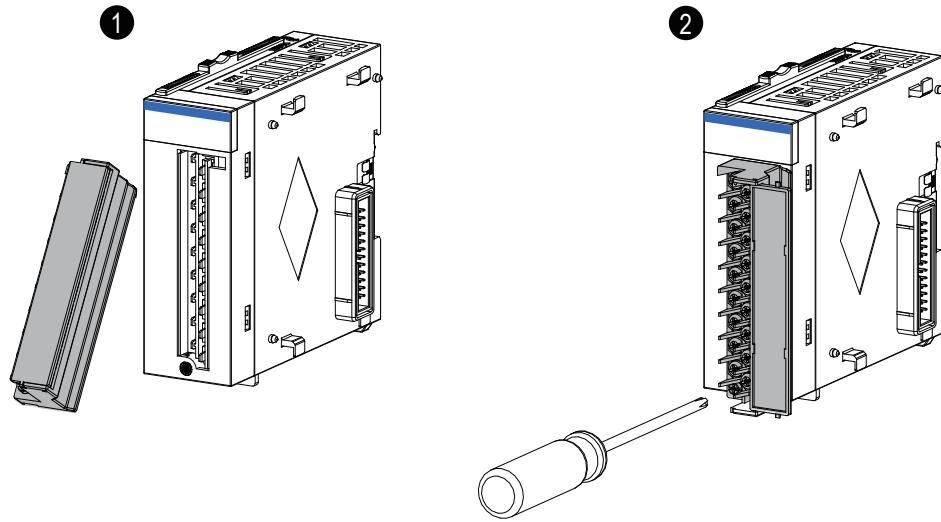

Figure 4-13 Terminal block installation

4.4 Installing and Removing the SD Card

1) SD card installation

The SD card slot uses a push-push structure. To install the SD card, open the small cover of the CPU module and insert the SD card into the slot, as shown in the following figure.

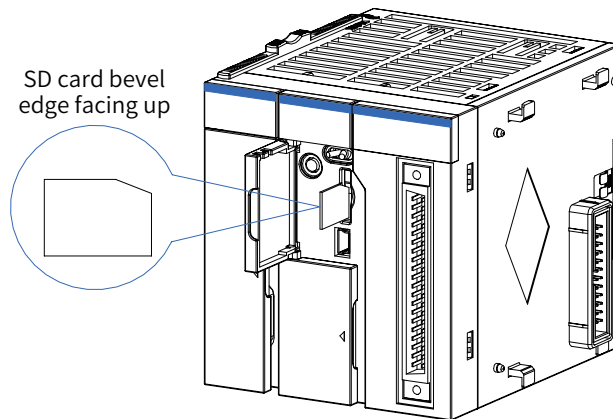

Figure 4-14 Installing the SD card

Ensure that the SD card is properly plugged in. Otherwise, the SD card is in poor contact, which may cause malfunction.

2) SD card removal

Push the SD card. The SD card is ejected. Then pull out the SD card straightly.

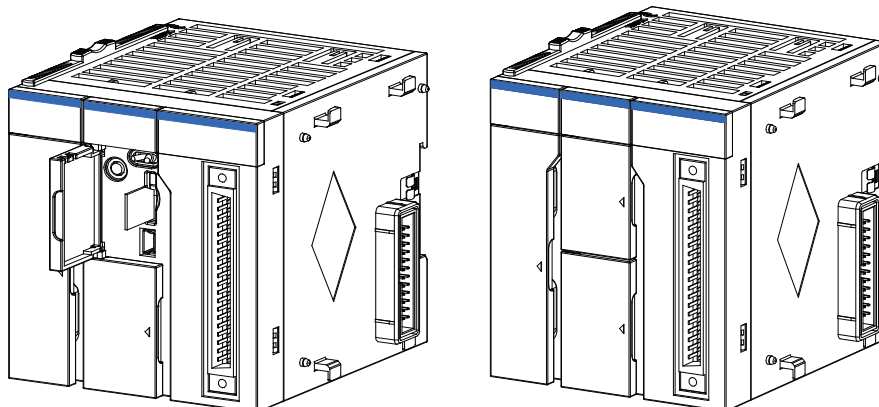

Figure 4-15 Removing the SD card



CAUTION

◆ Do not remove the SD card during use by any function.

4.5 Replacing Modules

Comply with the following requirements when replacing a module installed on the DIN guide rail:

If cables are connected to the modules, disconnect the cables or remove the terminal block and then perform the following steps:

- 1) Pull out the DIN guide rail installation hooks on the rear side of the modules.

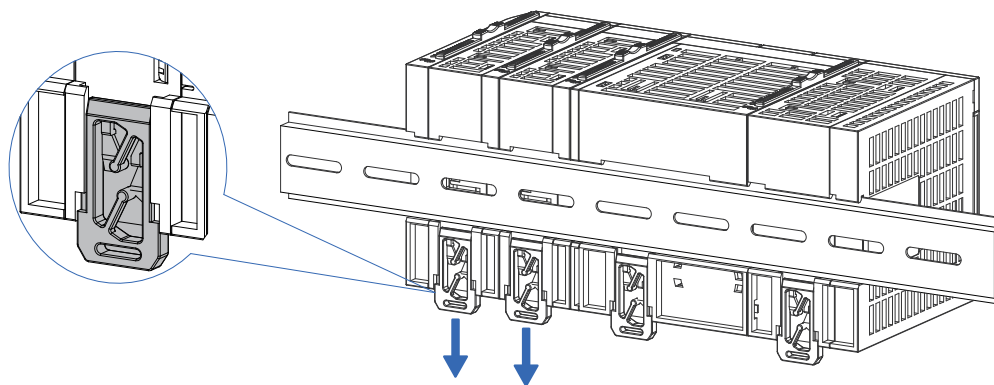

Figure 4-16 Pulling out the hooks in the shown direction

Pull out the DIN guide rail installation hooks of the module to be replaced and the module on the right of it until the hooks click. If your fingers cannot reach the DIN guide rail installation hooks, use a tool, for example, a screwdriver.

- 2) Slide the locks (① and ② in the following figure) on the module to be replaced and the module on the right of it to unlock them.

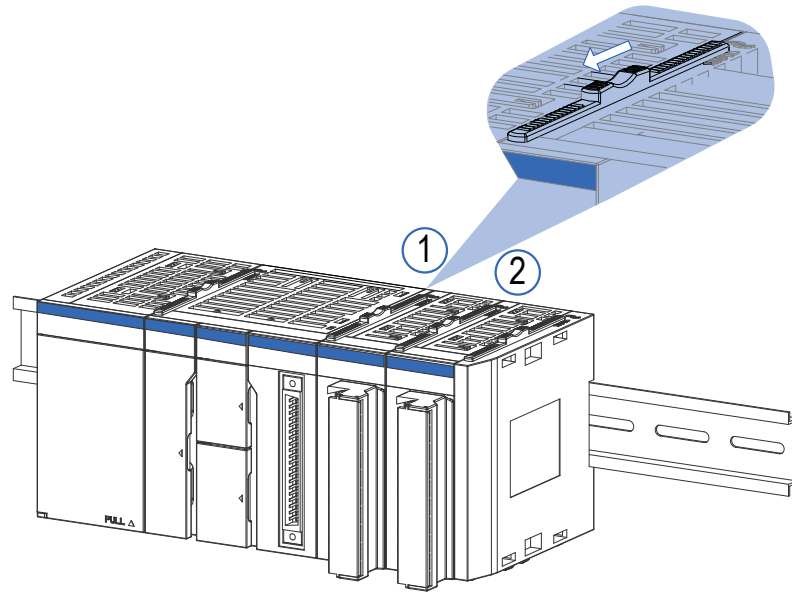

Figure 4-17 Unlocking the modules

- 3) Slide the modules to uninstall them.

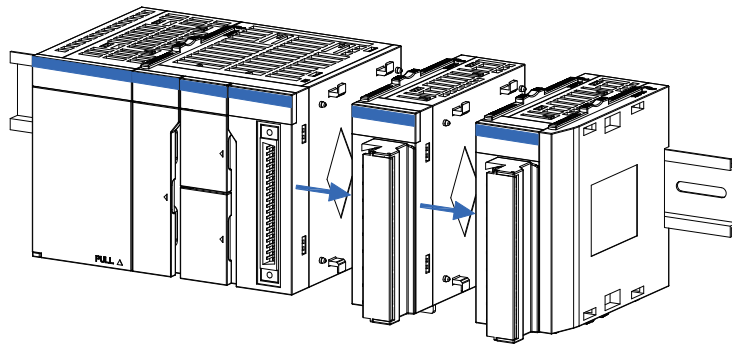

Figure 4-18 Sliding the unlocked modules

- 4) Replace the module.

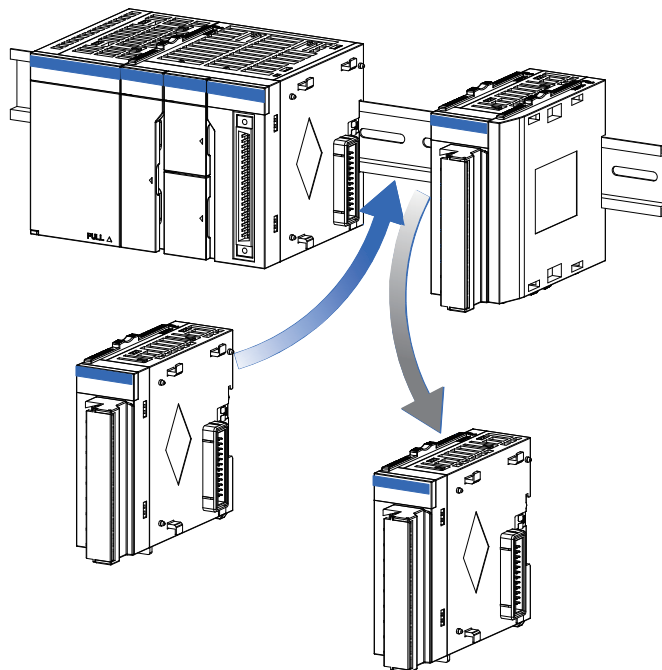

Figure 4-19 Replacing the module

- 5) Slide the modules to reconnect the connector.

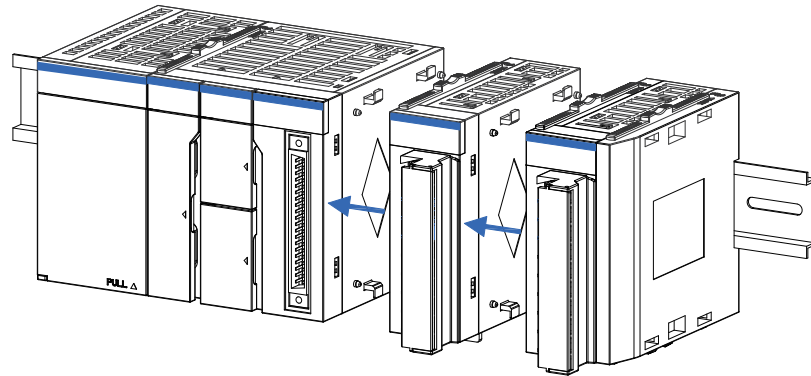

Figure 4-20 Sliding the modules

- 6) Lock the connection locks of the modules.



Chapter 5 Wiring



5.1 Wiring Suggestions	68
5.1.1 Grounding Requirements.....	68
5.1.2 Wiring Requirements	69
5.1.3 Installing the RFI Filter for the Power Module	70
5.1.4 Insulation Transformer	70
5.2 Selecting and Making Cables.....	71
5.2.1 Selecting Cables.....	71
5.2.2 Making Fork-lug Cables	71
5.2.3 Making Tubular-lug Cables	72
5.3 Wiring of the Power Module.....	72
5.3.1 Terminal Definition.....	72
5.3.2 Wiring Precautions	73
5.3.3 Grounding	73
5.4 High-speed I/O Wiring of the CPU Modules.....	74
5.4.1 Terminal Signals Arrangement.....	74
5.4.2 Wiring Precautions	74
5.4.3 External Wiring.....	75
5.5 Communication Wiring of the CPU Modules.....	77
5.5.1 Cable Connection Requirements.....	77
5.5.2 Connection Through the EtherCAT Bus	78
5.5.3 Connection Through the PROFIBUS-DP Bus.....	80
5.5.4 Connection Through the CANopen/CANlink Bus.....	84
5.5.5 Serial Communication Connection Through RS485	85
5.5.6 Monitoring Connection Through Ethernet	88
5.6 Wiring of Local Expansion Modules.....	90
5.6.1 DI Modules	90
5.6.2 DO Modules.....	93
5.6.3 AI Module.....	98
5.6.4 AO Module	100
5.6.5 Temperature Detection Modules	101

5.1 Wiring Suggestions

This section describes the cautions that you need to exercise when performing wiring for the power supply and input and output devices.

5.1.1 Grounding Requirements

1) Power and module grounding

Set a grounding point on the backplate near the power plate and paint it for protection. Use a thick cable shorter than 30 cm to connect the  terminal of the power module to the  terminal for grounding.

Install the AM600 series module on the conductive backplate according to the following figure and paint the bolts that connect the guide rail under the AM600 modules to the conductive backplate to ensure reliable connection.

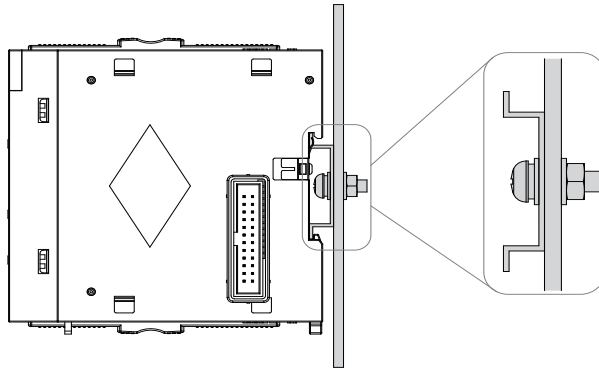

Figure 5-1 Installing the module on the conductive backplate

2) Shielded cable grounding

Use shielded cables for high-speed I/O, analog I/O, fieldbuses, and communication signals. The grounding point must be close to the module to prevent the cables from being affected by electromagnetic induction generated by the the surrounding cables. Ensure that the contact area between the shield exposed after some of the sheath of the shielded cable is peeled off and the conductive backplate is as large as possible to ensure good contact.

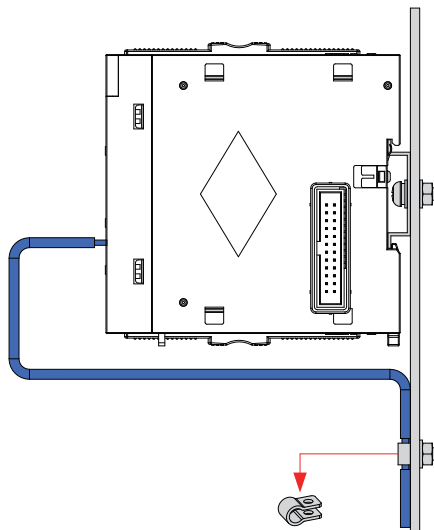

Figure 5-2 Shielded cable grounding requirement

If you solder a short cable to the end of the cable shield and connect the front end of this short cable to the ground, the high-frequency impedance increases, weakening the shield effect. Therefore, this method is not recommended.

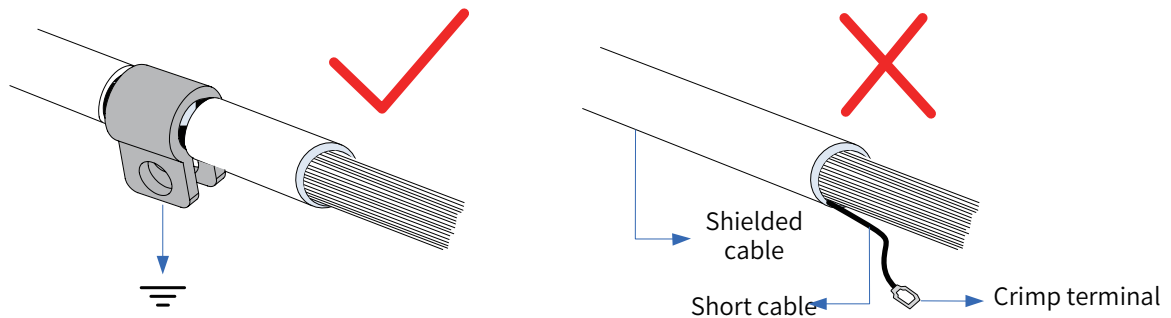

Figure 5-3 Shielded cable grounding requirement

The shield of analog signal cables must be connected to the ground at one end close to the module. The shield of high-speed I/O, fieldbus, and communication signals cables must be connected to the ground at both ends.

5.1.2 Wiring Requirements

Low-voltage cables (lower than 1 kV) are categorized into four types. Only cables of the same type can be bound together. Cables of different types must be laid separately. If cable crossing cannot be avoided, ensure right-angle crossing.

For cables shorter than 30 m, the allowable cable distance is shown in the following figure. You need to increase the distance between cables with increase of parallelly-laid length of the cables. You can also use shield plates assembled together between cables of different types to shield them from each other. To reduce crossing interference, cables must be laid as close as possible to the structural components connected to the cabinet ground, for example, the assembly plate and rack components of the cabinet.

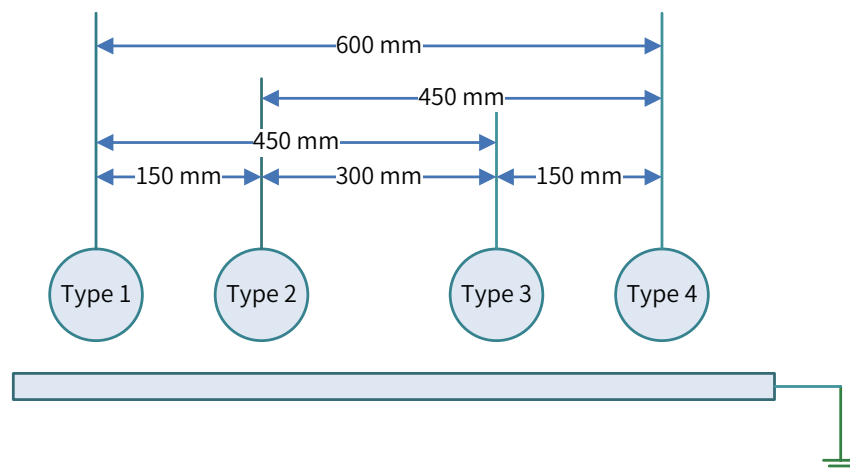

Figure 5-4 Wiring requirements for different types of cables

[Note] Type 1: Ethernet and EtherCAT cables

Type 2: low-speed digital communication signal cables (for example, RS232, RS485, and CAN signals) and digital I/O signal cables

Type 3: low-voltage AC distribution cables (for example, PLC 220 V AC power cables) and DC power cables (for example, DC 24 V power output by the switching-mode power supply)

Type 4: input and output cables, welding machine cables, and power cables of power converters

5.1.3 Installing the RFI Filter for the Power Module

When the AM600 series modules are used in environment with strong interference sources (for example, AC drive), you are advised to use an RFI filter to suppress noise.

RFI filter must be installed as close as the AM600 power module as possible and mounted to the conductive backplate with screws to ensure properly grounding. In principle, the input cables of RFI filter must be separated from the output cables of RFI filter to prevent the noise of the cables at the output side (load) of the filter from being directly coupled to the cables at the input side (mains) of the filter.

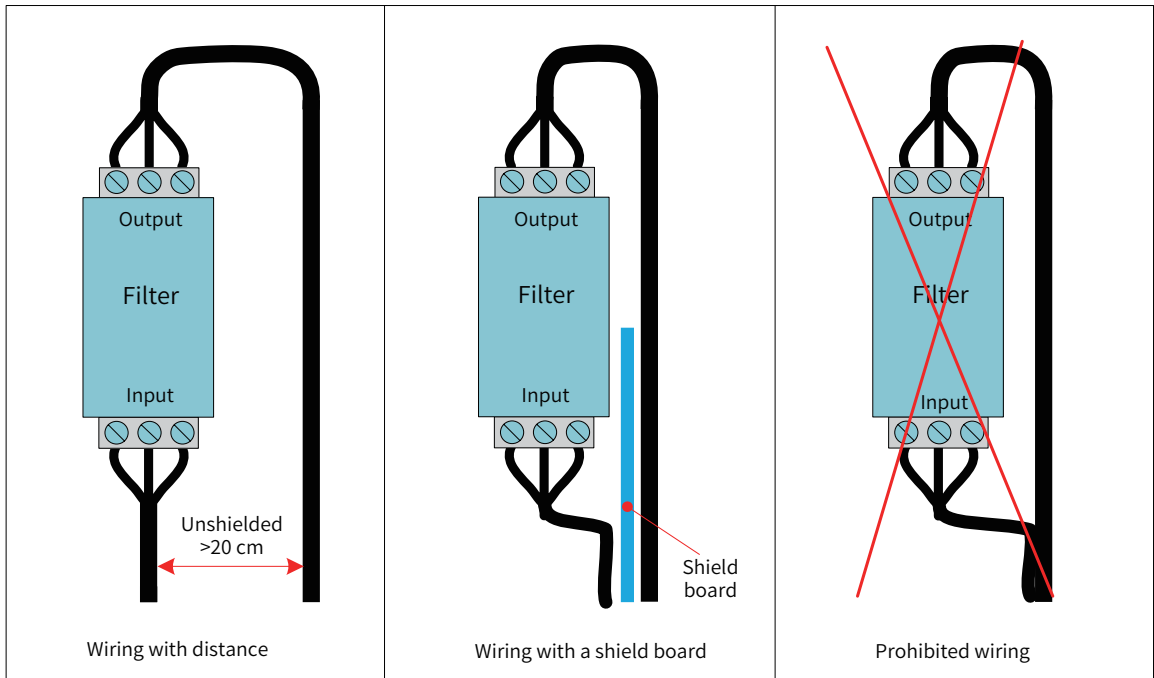

Figure 5-5 Power filter installation

5.1.4 Insulation Transformer

The insulation transformer is a component that suppresses conducted noise (especially surge noise that may cause PLC malfunction). As a surge noise suppression device that reduces the impact of lightning, the insulated transformer is connected as shown in the following figure.

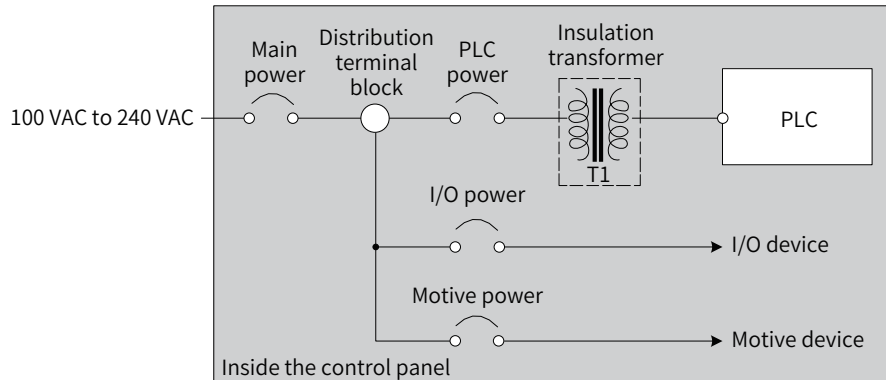

Figure 5-6 Working principle of the insulation transformer

5.2 Selecting and Making Cables

5.2.1 Selecting Cables

Applicable Module	Cable Lug	Model	American standard/AWG	Crimping Plier
Power module	Fork lug	TNS1.25-4	22-16	RYO-8 YYT-8
16-channel DI/DO modules	Fork lug	TNS1.25-3	22-18	RYO-8 YYT-8
32-channel DI/DO modules	Tubular lug	GTVE10006	18	YAC-5
AI/AO modules	Fork lug	TNS1.25-3	22-18	RYO-8 YYT-8
Temperature detection modules	Fork lug	TNS1.25-3	22-18	RYO-8 YYT-8

The rated cable temperature shall be above 75 °C .

5.2.2 Making Fork-lug Cables

The procedure for making a fork-lug cable is as follows:

- 1) Peel off the insulation coating by 6 mm.
- 2) Pass the cable through a cable marker sleeve of proper size.
- 3) Insert the exposed end of the cable into the round hole of the lug and use the recommended crimping plier to crimp the hole.
- 4) Insert the lug into a 20 mm-long heat-shrinkable sleeve ($\Phi 3$), cover the copper part of the lug, and then apply heat to make the heat-shrink sleeve shrink.

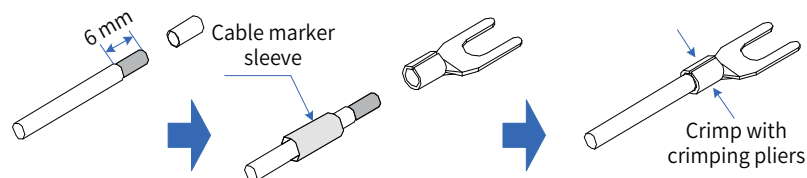

Figure 5-7 Making a fork-lug cable

- 5) Insert the lug into the terminal block and use a screwdriver to tighten it. The applied torque cannot exceed 0.8 N·m.

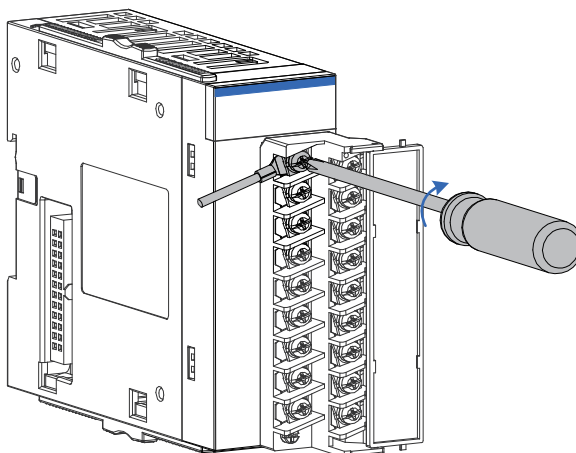

Figure 5-8 Connecting a cable to the terminal block

5.2.3 Making Tubular-lug Cables

The procedure for making a tubular cable is as follows:

- 1) Peel off the insulation coating by 6 mm and pass the cable through a cable marker sleeve.
- 2) Insert the exposed end of the cable into the round hole of the lug and use the recommended crimping plier to crimp the hole.
- 3) Insert the lug into the terminal block and use a screwdriver to tighten it. The applied torque cannot exceed 0.45 N·m.

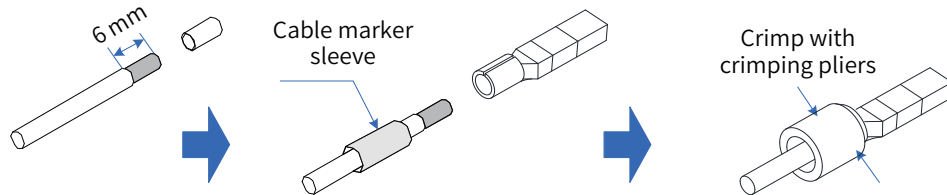
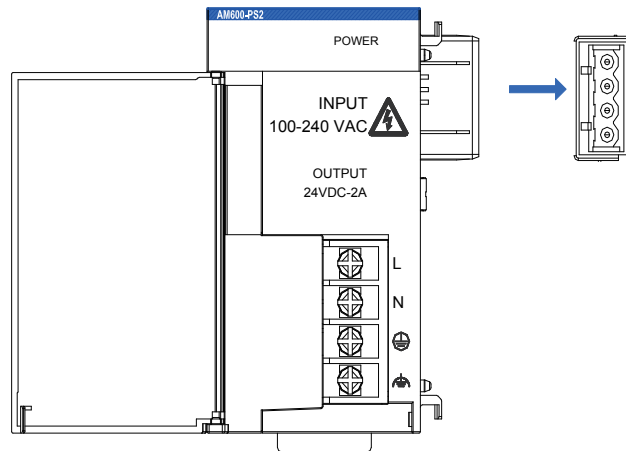

Figure 5-9 Making a tubular cable

5.3 Wiring of the Power Module

5.3.1 Terminal Definition

The following figure shows the power module AM600-PS2 and the wiring terminal definitions:





Symbol	Type	Function
L	Input	AC L input
N	Input	AC N input
	Ground	Protective ground (connected to the ground wire of the AC input power)
	Ground	Function ground (connected to the system housing)
+24 V	Output	DC 24 V positive
GND	Output	DC 24 V ground

Figure 5-10 Wiring terminal definitions of the power module

5.3.2 Wiring Precautions

- 1) Ensure that the external power supply is switched off during installation and wiring to avoid electric shock and module damage.
- 2) Use a thick cable (max. sectional area: 2 mm²) as the 110 V/220 VAC power cable, twist the cable at the terminal, and keep the power cable part connected to the terminal as short as possible to avoid short circuit when the screw is loose.
- 3) Do not bind the 110 V/220 VAC power cable with the 24 VDC power cable, I/O signal cable, and communication cable. Keep them as far from each other as possible.
- 4) After the power is switched on, the 24 VDC indicator is on, indicating that the power supply is working properly. If the indicator is off, the power module input or the power module itself may be faulty.
- 5) Use 16 - 22 AWG single-core or multi-core copper cables whose rated temperature is above 75 °C on the wiring side. The tightening torque of the power terminal screw is 9.5 kg-cm (8.25 in-lbs).

5.3.3 Grounding

- 1) Connect the L and N (100 VAC to 240 VAC, 50/60 Hz) lines to the L and N terminals of the power module and connect the ground line of the power supply to the  terminal of the module.
- 2) Connect the  terminal of the power module to the nearest machine housing as the reference ground. Comply with the following grounding requirements:

- The diameter of the ground cable cannot be smaller than that of the L and N cables on the power side;

- Use single point grounding when multiple devices are used simultaneously;

- When single point ground is not allowed, use common grounding as shown on the right;

- Do not connect to the ground as shown on the right!

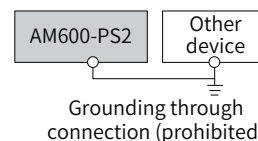
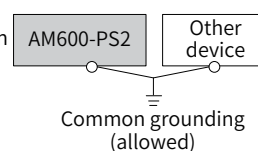
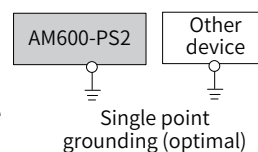

Figure 5-11 Power module grounding requirements

- 3) Use a cable thicker than 2 mm² as the grounding cable and ensure that the grounding impedance is less than 100 Ω.

5.4 High-speed I/O Wiring of the CPU Module

5.4.1 Terminal Signals Arrangement

The AM600/610 CPU modules support high-speed I/O. They provide a high-density port which supports 16-channel high-speed input (the first 6 channels support 24 V single-end input or differential input and the last 10 channels support 24 V single-end input) and 8-channel high-speed output.

The following figure shows the high-density port (CN5):

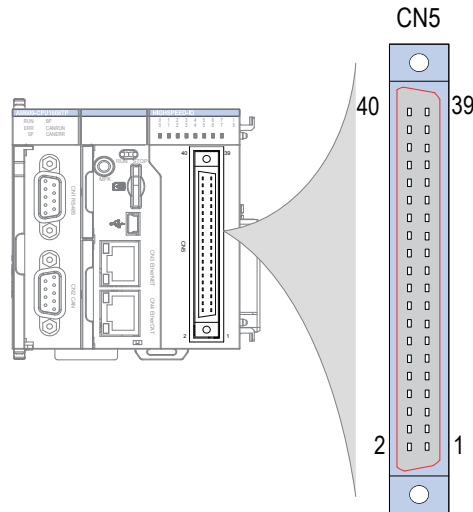

Figure 5-12 Wiring terminal definitions of the CPU module

For the requirements on the internal circuit and external wiring of the port, see Section ["5.4.3 External Wiring"](#). Ensure that the wiring meets the corresponding requirements.

5.4.2 Wiring Precautions

- 1) The total extended distance of the extension cable of the high-speed I/O interface must be less than 3.0 m.
- 2) Avoid binding extension cables with cables that generate strong interference, for example, power cables (high voltage and current), and avoid laying extension cables parallelly with those cables.
- 3) Use the recommended cables and connection terminal block. You are advised to use shielded cables as extension cables to improve the interference resistance capability.
- 4) When laying extension cables, ensure that the turning radius is greater than 76 mm. Otherwise, malfunction may occur due to performance deterioration and cable break.

5.4.3 External Wiring

External Wiring	Signal	CN5 Pin No.		Signal	Internal Circuit
	Column B			Column A	
	High-speed 24 V input (Xn0-24 V)	40	39	High-speed 24 V input (Xn2-24 V)	
	High-speed differential input (Xn0-DIFF)	38	37	High-speed differential input (Xn2-DIFF)	
	High-speed input common terminal (Xn0-COM)	36	35	High-speed input common terminal (Xn2-COM)	
	High-speed 24 V input (Xn1-24V)	34	33	High-speed 24 V input (Xn3-24 V)	
	High-speed differential input (Xn1-DIFF)	32	31	High-speed differential input (Xn3-DIFF)	
	High-speed input common terminal (Xn1-COM)	30	29	High-speed input common terminal (Xn3-COM)	
	High-speed 24 V input (Xn4-24V)	28	27	High-speed 24 V input (Xn5-24V)	
	High-speed differential input (Xn4-DIFF)	26	25	High-speed differential input (Xn5-DIFF)	
	High-speed input common terminal (Xn4-COM)	24	23	High-speed input common terminal (Xn5-COM)	
	Input common terminal (SS0)	22	21	Input common terminal (SS1)	
	Standard input (Xn6)	20	19	Standard input (Xn7)	
	Standard input (Xn8)	18	17	Standard input (Xn9)	
	Standard input (XnA)	16	15	Standard input (XnB)	
	Standard input (XnC)	14	13	Standard input (XnD)	
	Standard input (XnE)	12	11	Standard input (XnF)	
	Output (Yn0)	10	9	Output (Yn1)	
	Output (Yn2)	8	7	Output (Yn3)	
	Output (Yn4)	6	5	Output (Yn5)	
	Output (Yn6)	4	3	Output (Yn7)	
	Output common terminal (COM0)	2	1	Output common terminal (COM1)	

Figure 5-13 External wiring

If the SIRON T024-K connection terminals are used to connect the system wires, see the following figure for the relationship between the terminal numbers and the CN5 pin numbers of the module:

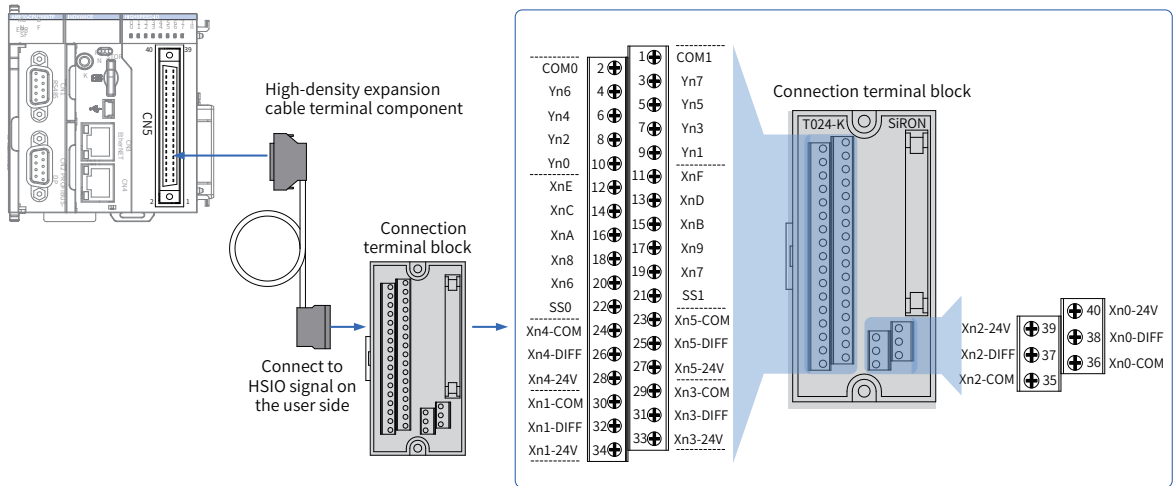

As shown in the preceding figure, Inovance provides the following items:

- ① High-density extension cables.
- ② Connectors (used to make cables).
- ③ Connection terminal block. The order information is as follows:

No.	Order Code	Description	Remarks
①	15300119	40-pin FCN to MIL cable (500 mm)	High-density extension cable, including a 40-pin FCN connector and an MIL connector.
	15300193	40PIN FCN to MIL cable (2000 mm)	
②	15050180	40-pin FCN connector	You can purchase this connector to make cables yourself.
③	15020452	40-pin MIL to screw connection terminal block	

The following figure shows the wiring of the SIRON T024-K connection terminal block:

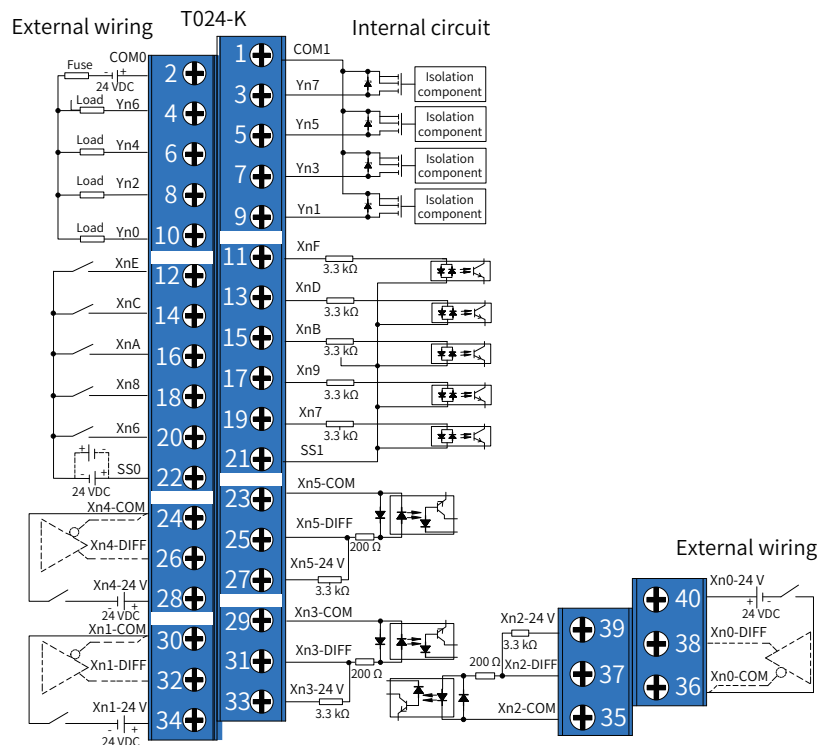

Figure 5-14 Wiring of the SIRON T024-K connection terminal block



NOTE

◆ Note: The preceding figure shows the pin definitions and wiring of the high-density port of the AM600/610 CPU module. Read it carefully before performing wiring.

5.5 Communication Wiring of the CPU Module

5.5.1 Cable Connection Requirements

Connecting the DB9 connector

- 1) Plug the DB9 connector (with a cable) to the DB9 plug of the module. (Ensure that the connector direction is correct.)
- 2) Tighten the screws on the two sides of the DB9 connector.

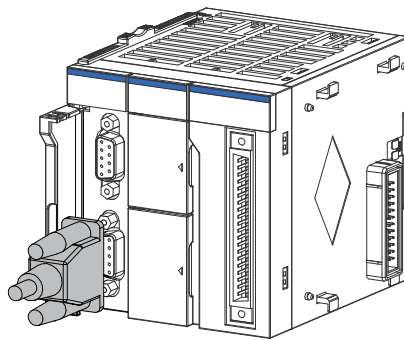

Figure 5-15 Connecting the DB9 connector

Removal procedure: Unscrew the screws on the two sides of the DB9 connector, hold the plastic part of the connector, and pull it out horizontally.

Connecting the RJ45 cable.

Hold the RJ45 connector (with a cable) and insert it to the RJ45 socket of the communication module until it clicks.

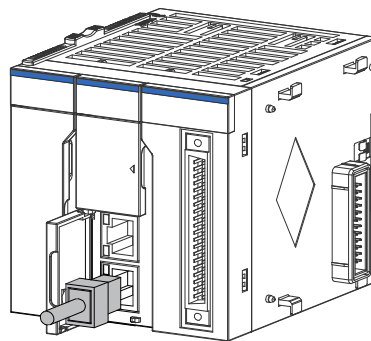

Figure 5-16 Connecting the network cable

Removal procedure: Hold the tail of the RJ45 connector and pull it out horizontally.

Ethernet cable specifications:

Cat5e shielded twisted pair cable with steel-shell molding wires



Figure 5-17 Ethernet cable specifications

To prevent communication cables from being affected by mechanical forces and ensure communication stability, fix the cables close to the device before starting to use the modules, as shown in the following figure:

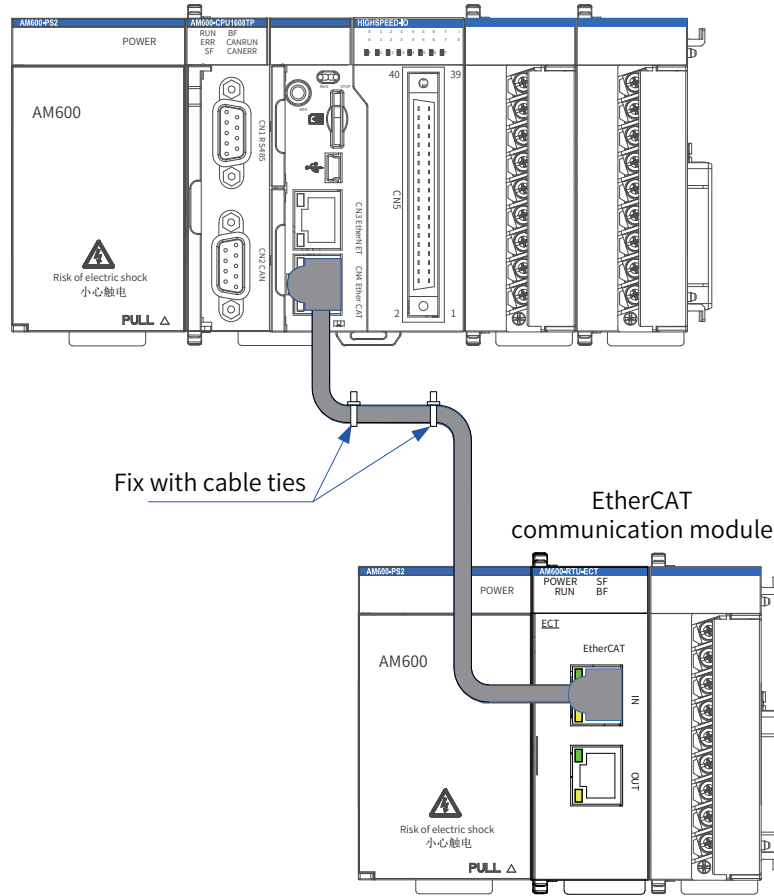

Figure 5-18 Fixing the communication cable close to the device

5.5.2 Connection Through the EtherCAT Bus

1 Communication ports

Connect the ports of the CPU module and EtherCAT communication modules according to the following figure.

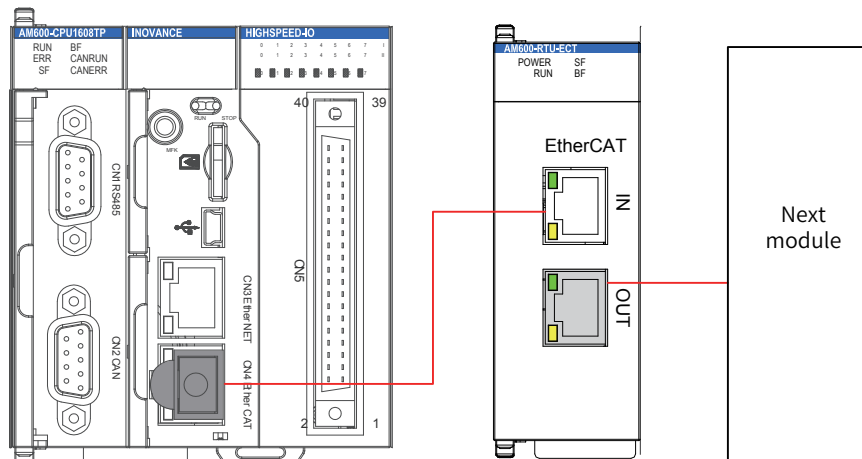

Figure 5-19 CN4 port of the main CPU module and IN/OUT ports of the EtherCAT communication module

The following table lists the performance indicators:

Item	Specifications
Communication protocol	EtherCAT
Services supported	CoE (PDO, SDO)
Minimum synchronization period of 6-axis cam	2000 μ s
Synchronization mode	The servo uses a DC-distributed clock. I/O uses I/O synchronization.
Physical layer	100BASE-TX
Baud rate	100 Mbit/s (100Base-TX)
Duplex mode	Full duplex
Topological structure	Cyclic topological structure
Transmission medium	Network cable
Transmission distance	Less than 100 M between two nodes
Number of slaves	65535
EtherCAT frame length	44 bytes to 1498 bytes
Process data	A single Ethernet frame contains a maximum of 1486 bytes.
Synchronization jitter of two slaves	< 1 μ s
Refresh time	1000 digital inputs and outputs: approximately 30 μ s; 32 servo axes: approximately 100 μ s

2 Wiring

■ Network cables specifications

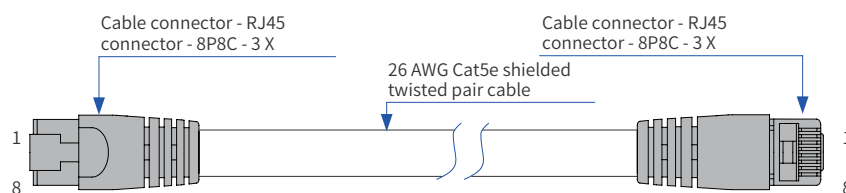

Figure 5-20 EtherCAT network cable specifications

■ Signal pin arrangement

Pin	Signal	Signal Direction	Signal Description
1	TD+	Output	Data transmission +
2	TD-	Output	Data transmission -
3	RD+	Input	Data reception +
4	--	--	Not in use
5	--	--	Not in use
6	RD-	Input	Data reception -
7	--	--	Not in use
8	--	--	Not in use

■ Length requirement

The FastEthernet technology has proved that the cable length between devices cannot exceed 100 m when the EtherCAT bus is used. Otherwise, signal attenuation occurs, adversely affecting communication.

■ Technical requirements

No short circuit, circuit break, misplacement, or poor contact is detected in the conductivity test. The cable length is within the allowable tolerance range.

The EtherCAT bus transfers network data through a shielded cable. The following table lists the cable specifications:

Item	Specifications
Cable type	Elastic crossover cable, S-FTP, Cat5e
Standards	EIA/TIA568A, EN50173, ISO/IEC11801 EIA/TI Abulletin TSB, and EIA/TIA SB40-A&TSB36
Wire section	AWG26
Wire type	Twisted pair
Number of pairs	4

5.5.3 Connection Through the PROFIBUS-DP Bus

1 PROFIBUS-DP bus specifications

Item	Specifications
Protocol	DP-V0
Number of slave stations	124 (add a PROFIBUS-DP relay every 32 stations)
Communication rate	9.6 Kbit/s, 19.2 Kbit/s, 45.45 Kbit/s, 93.75 Kbit/s, 187.5 Kbit/s, 500 Kbit/s, 1.5 Mbit/s, 3 Mbit/s, 6 Mbit/s, and 12 Mbit/s
Communication data volume of a single slave station	244 bytes/slave
Total data volume of network communication	5712 bytes/input; 5760 bytes/output
Basic functions	Initial state, parameter setting state, and data exchange state
Special function	Diagnosis. For details, see "7.2 Indicators and MFK Button" .
Error indicator	SF and BF. For details, see "7.2 Indicators and MFK Button" .

2 Wiring diagram

The following figure shows the wiring between the PROFIBUS-DP slave station and the PROFIBUS master station:

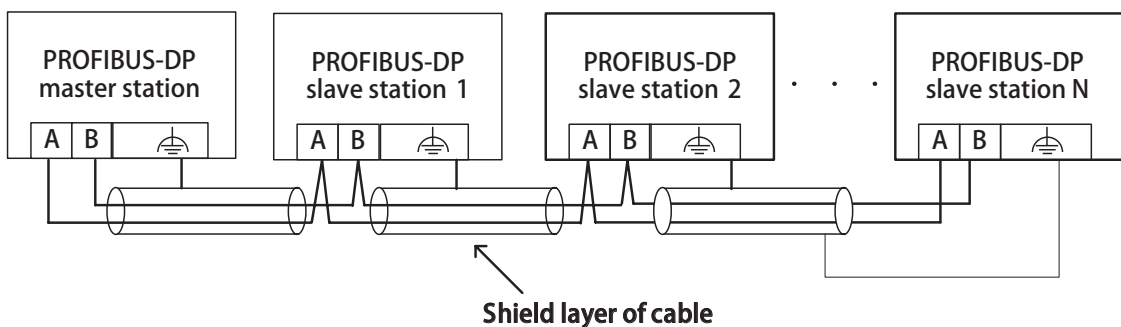

Figure 5-21 Network connections

A termination resistors is required for the PROFIBUS-DP communication bus. The standard PROFIBUS-DP DB9 connector has already a inbuilt termination resistors, and you only need to set DIP switch to enable the termination resistor. For details, see [Figure 5-25](#).The system PE must be securely grounded.

The length of the communication cable between the PROFIBUS-DP card and the PROFIBUS master station

varies according to the communication baud rate of the master station, and the communication data cable length must comply with the Siemens DB9 wiring standard. Due to reasons such as interference and cable tolerance transmission distance of the PROFIBUS-DP bus reaches approximately 60% of the theoretical value in the actual environment.

The following table lists the requirements on the baud rate and cable length:

Transmission Rate	theoretical Transmission Distance (m)	Actual Reachable Maximum Transmission Distance (m)
9.6 Kbps to 93.75 Kbps	1000	600
187.5 Kbps	800	480
500 Kbps	400	320
1.5 Mbps	200	160
12 Mbps	100	60

The following table lists the technical specifications of cables:

Parameter	Type A	Type B
Impedance	135 Ω to 165 Ω (f = 3 MHz to 20 MHz)	100 Ω to 130 Ω (f > 100 KHz)
Capacitance	< 30 pF/m	< 60 pF/m
Resistance	< 110 Ω /km	Not specified
Conductor sectional area	$\geq 0.34 \text{ mm}^2$	$\geq 0.22 \text{ mm}^2$

3 Communication port introduction

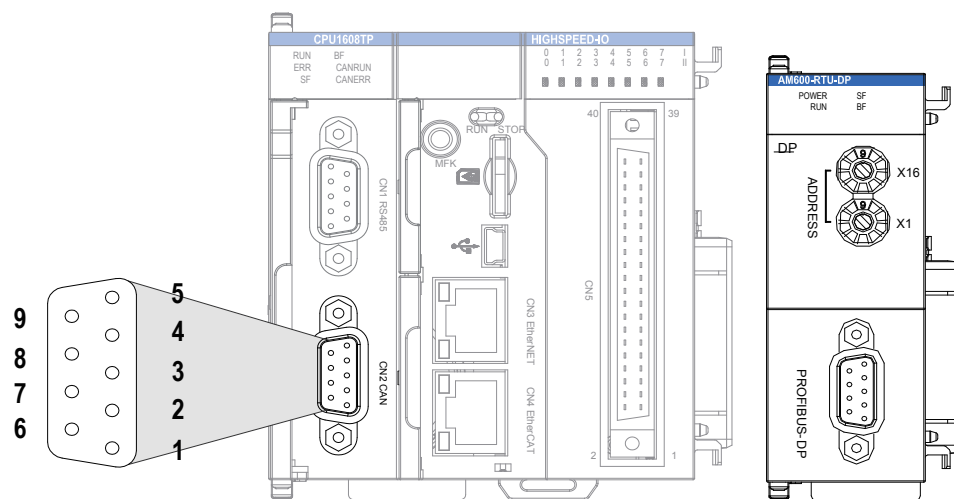

Figure 5-22 DB9 terminal on the CPU module

As shown in the preceding figure, the communication port uses a DB9 socket. Use PROFIBUS-DP cables for the connection. (Recommended cable: Siemens 6XV1830-0EH10) The following figure shows the connection:

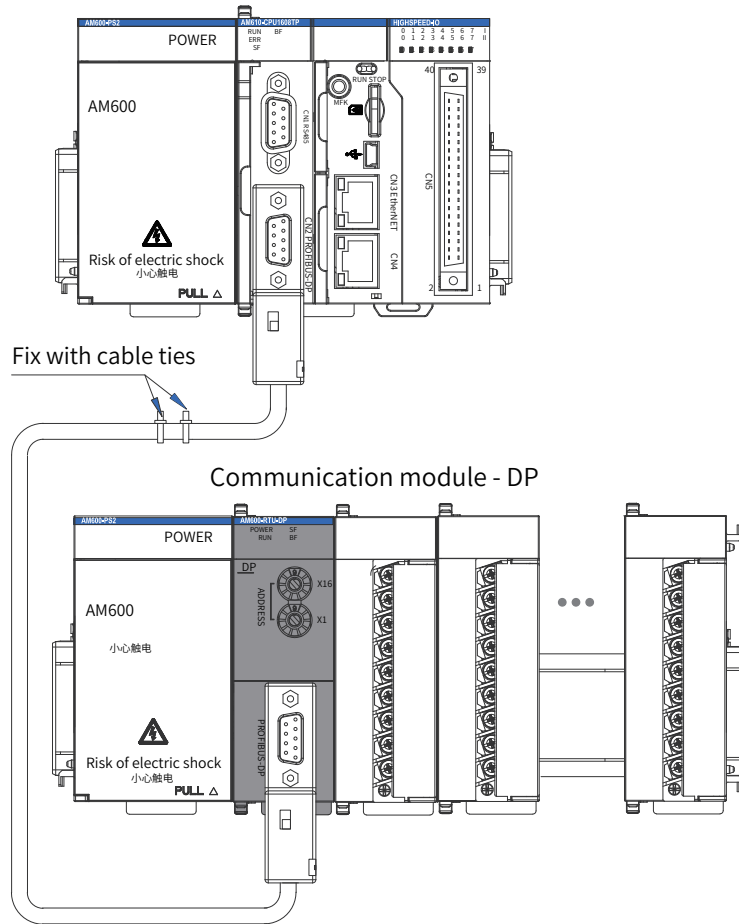

Figure 5-23 Cable fixing requirement



◆ To prevent communication cables from being affected by mechanical forces and ensure communication stability, fix the cables close to the device before PROFIBUS-DP communication starts.

4 Connecting the DB9 connector

- 1) Connect the PROFIBUS-DB cable connected to the main module to the inlet of the DB9 connector and connect the cable to be connected to the subsequent expansion rack to the outlet of the DB9 connector.
- 2) Plug the DB9 connector (with a cable) to the DB9 plug of the module. (Ensure that the connector direction is correct).
- 3) Tighten the screws on the two sides of the DB9 connector.

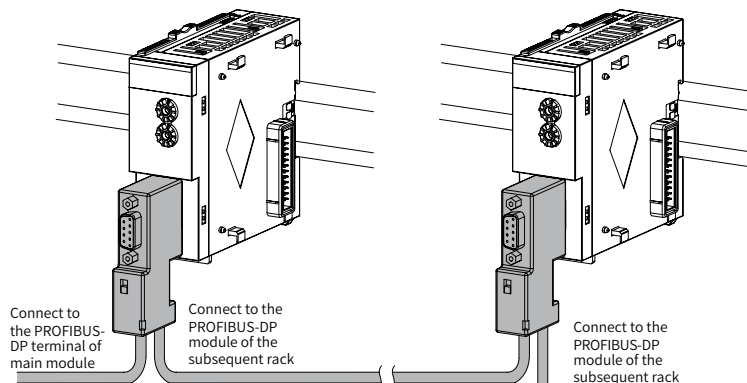

Figure 5-24 DB9 connection

- 4) Removal procedure: Unscrew the screws on the two sides of the DB9 connector, hold the plastic part of the connector, and pull it out horizontally.

■ Standard PROFIBUS DB9 pin description

The PROFIBUS-DP module uses a standard DB9 socket to connect to the PROFIBUS master station. The pin signals comply with the definition of the standard Siemens DB9 socket.

Control terminal function description:

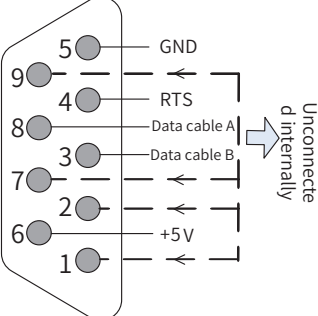
Type	Terminal Number	Terminal Name	Function
	1, 2, 7, and 9	NC	Not connected
	3	Data cable B	Data cable +
	4	RTS	Request to send
	5	GND	Isolated 5 V power ground
	6	+5 V	Isolated 5 V power
	8	Data cable A	Data cable -
	9	GND	

■ Wiring

A DB9 connector (female socket) equipped with a termination resistor is used as the PROFIBUS-DP communication connector. The connector is compatible with a universal PROFIBUS-DP interface. This connector is designed and manufactured by Inovance, as shown in the following figure.

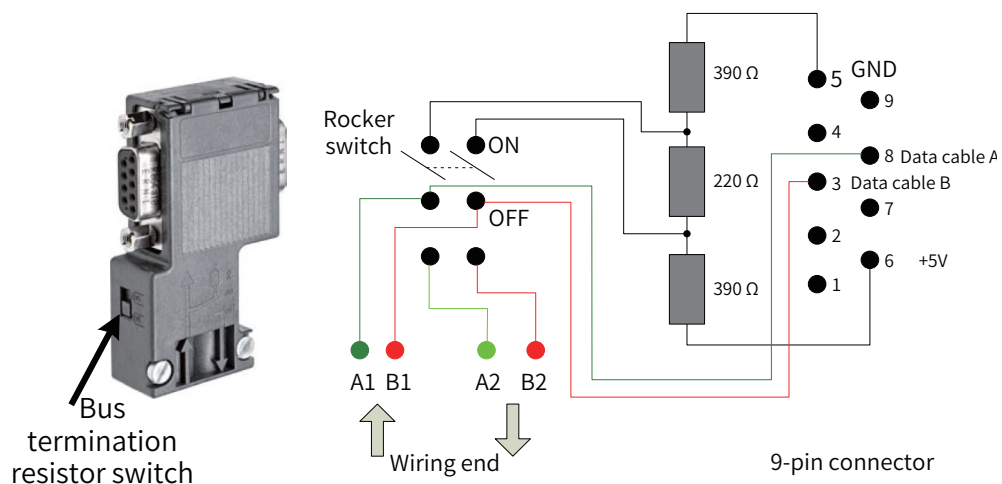

Figure 5-25 DB9 connector circuit

For PROFIBUS-DP, the theoretical transmission distance is 1000 m when the transmission rate is 9.6 Kbps. The theoretical distance can be achieved only in standard PROFIBUS-DP test lab environment. If the PROFIBUS-DP cable and PROFIBUS-DP connector are flawless and the wiring is proper (separate from the power cables), the distance can reach 80% of the theoretical value. In reality, the distance is approximately 60% of the theoretical value. In addition, relay modules need to be added when the transmission distance exceeds the threshold. Based on the preceding condition, in the AM600 project, the maximum transmission distance of PROFIBUS-DP is set to 60% of the theoretical value. For details, see the following table:

Transmission Rate	Theoretical Transmission Distance (m)	Actual Reachable Maximum Transmission Distance (m)
9.6 Kbps to 93.75 Kbps	1000	600
187.5 Kbps	800	480
500 Kbps	400	320
1.5 Mbps	200	160
12 Mbps	100	60

5.5.4 Connection Through the CANopen/CANlink Bus

■ Wiring diagram

The following figure shows the topological structure of the CAN bus connection. You are advised to use a shielded twisted pair for CAN bus connection and connect two 120 Ω termination resistors at both ends of the bus to avoid signal reflection. Generally, the shield layer uses single point grounding.

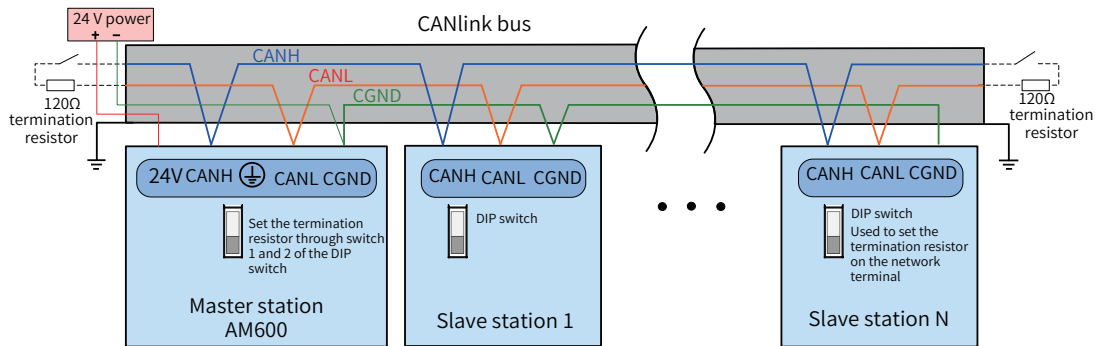

Figure 5-26 CANopen/CANlink communication connection

■ Communication port introduction

CN2 of the CPU module is the CANopen communication terminal and uses a DB9 connector for data transmission.

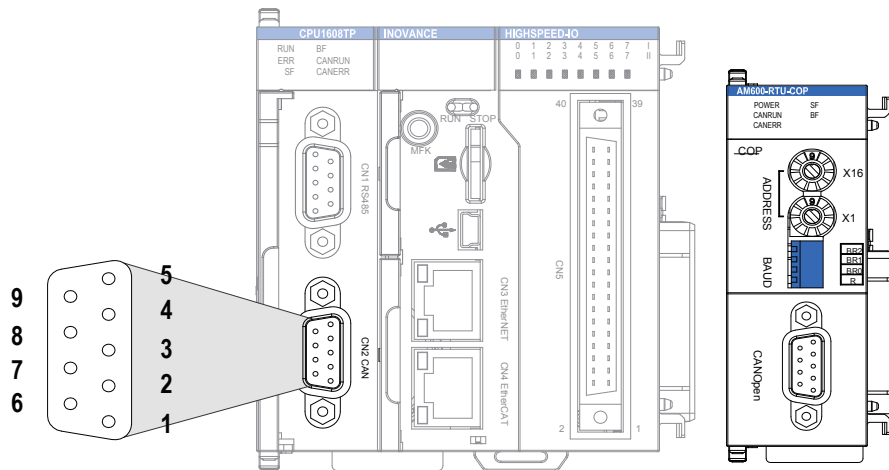
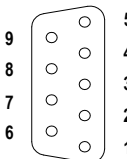

Figure 5-27 CANopen terminal definitions of the CPU module

5) Wiring

CANopen uses a DB9 connector for data transmission. The following table defines the DB9 pins:

Pin Diagram	Pin	Signal Definition
	PIN2	CANL
	PIN7	CANH
	PIN3	CGND

You are advised to use a shielded twisted pair for CAN bus connection and connect two 120 Ω termination resistors at both ends of the bus to avoid signal reflection. The shield layer uses single point ground-ing. Do not bind the cable together with the AC power cable or high-voltage cable to prevent communication signals from being interfered.

The following table lists the relationship between the DIP switch value of the CANopen module and the communication baud rate:

DIP switch value (BR2/BR1/BR0)	0	1	2	3	4	5	6	7
Baud rate (bit/s)	1 M	800 K	500 K	250K	125K	50 K	20 K	10 K

The following table lists the relationship between the CANopen transmission rate and the transmission distance:

Baud Rate (bit/s)	Max. Bus Length (m)
1 M	30
500 K	80
250 K	150
125 K	300
50 K	1000

The following table lists the relationship between the number of CANopen nodes, cable impedance, and transmission distance:

Max. node count Communication cable resistance	16	32	64
	33 Ω /km	575 m	530 m
70 Ω /km	270 m	250 m	215 m
88 Ω /km	215 m	200 m	170 m
93 Ω /km	205 m	185 m	160 m
157 Ω /km	120 m	110 m	95 m

5.5.5 Serial Communication Connection Through RS485

1) RS485 bus connection topology

The following figure shows the topological structure of the RS485 bus connection. You are advised to use a shielded twisted pair for RS485 bus connection and use twisted pairs to connect the 485+ and 485- terminals. Connect a 120 Ω termination resistor at both ends of the bus to avoid signal reflection. Connect the reference ground of RS485 signals of all nodes. A maximum of 128 nodes can be connected, and the distance of each branch cable must be less than 3 m.

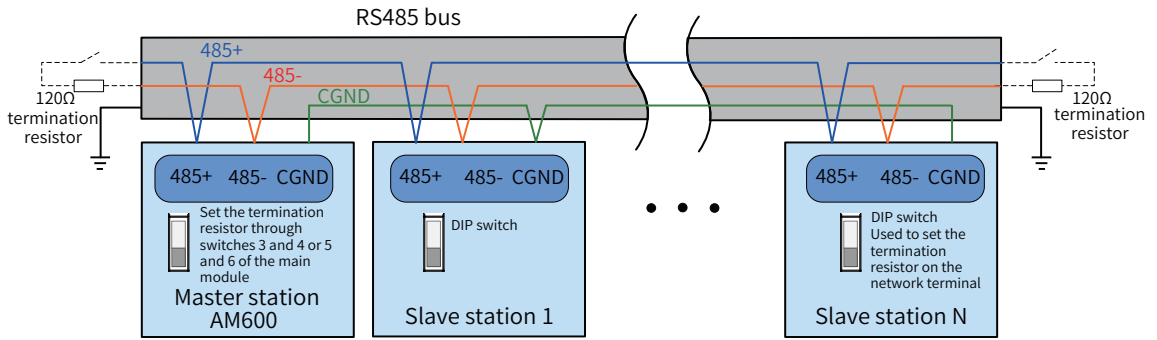

Figure 5-28 RS485 communication connection

■ Multi-node connection

When the number of nodes is large, the RS485 bus uses the daisy chain connection mode. If branch cables need to be connected, you are advised to keep the branch cable length between the bus and the node shorter than 3 m. Do not use the star-shaped connection mode. The following figure shows the common bus structure:

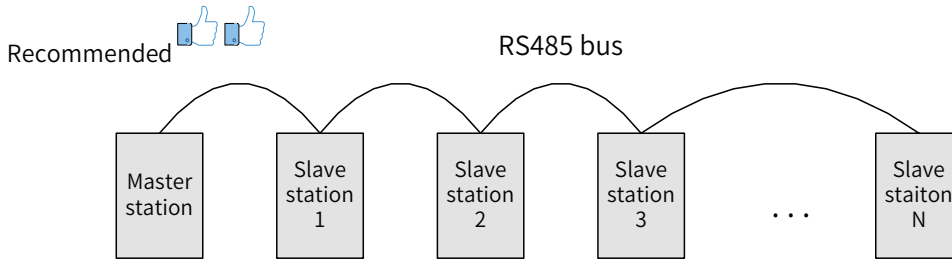

Figure 5-29 Daisy chain connection structure

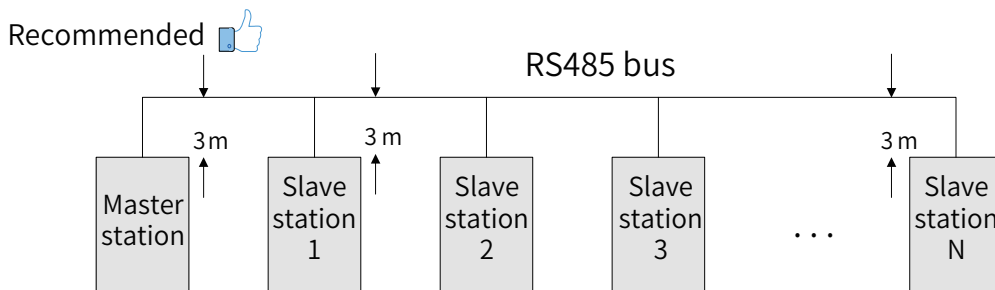

Figure 5-30 Keep the branch cable length shorter than 3 m when branch cables are used

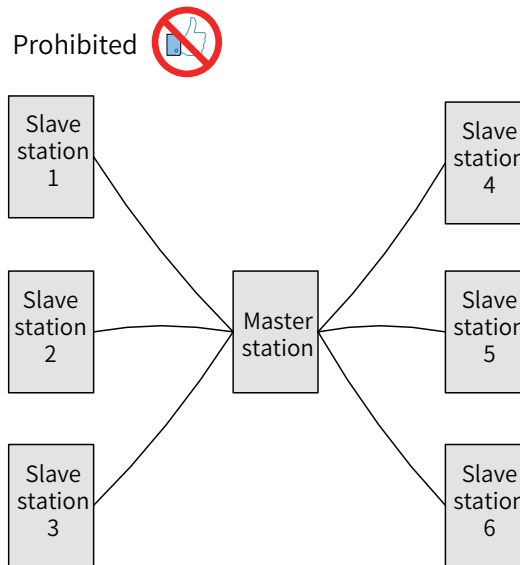

Figure 5-31 Incorrect star-shaped connection mode

■ Terminal wiring mode

① For nodes with the CGND terminal

Check whether the RS485 bus contains three cables that connect to the 485+, 485-, and CGND terminals and ensure that the terminals are not connected incorrectly or reversely. If shielded cables are used, the shield layer must be connected to the CGND terminal. At any node or middle position, the shield layer cannot connect to any position (including the machine housing and device ground terminal) other than the CGND terminal of the node.

Due to attenuation in the cable, you are advised to use AWG26 or thicker cables if the cable length exceeds 3 m and use twisted pair cables to connect the 485+ and 485- terminals at any time.

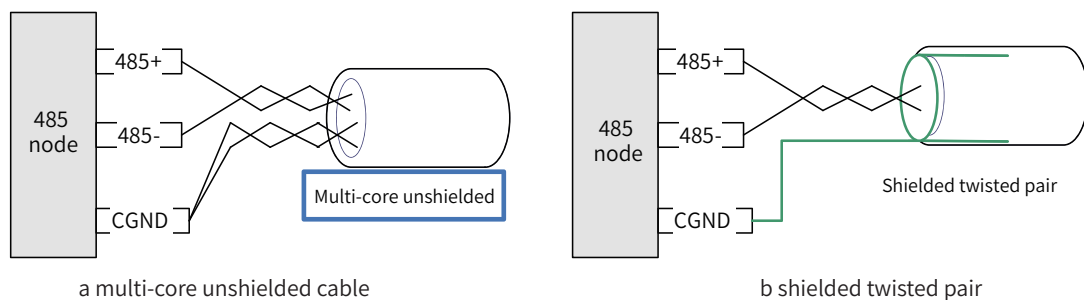

Figure 5-32 Connection for nodes with the CGND terminal

Recommended cable 1: multi-core cable with twisted pairs. Use one of the twisted pairs as the connection cable for the 485+ and 485- terminals, and twist others into one as the connection cable of the CGND terminal.

Recommended cable 2: twisted pair cable with a shield layer. Use the twisted pair as the connection cable for the 485+ and 485- terminals, and use the shield layer as the connection cable of the CGND terminal.

If the shield cable is used as the connection cable, ensure that the shield layer is only connected to the CGND terminal but is not connected to the main earth of the site.

② For nodes without the CGND terminal

If the node does not have the CGND terminal, do not connect the CGND or shield layer to the PE of the node, but use the following methods:

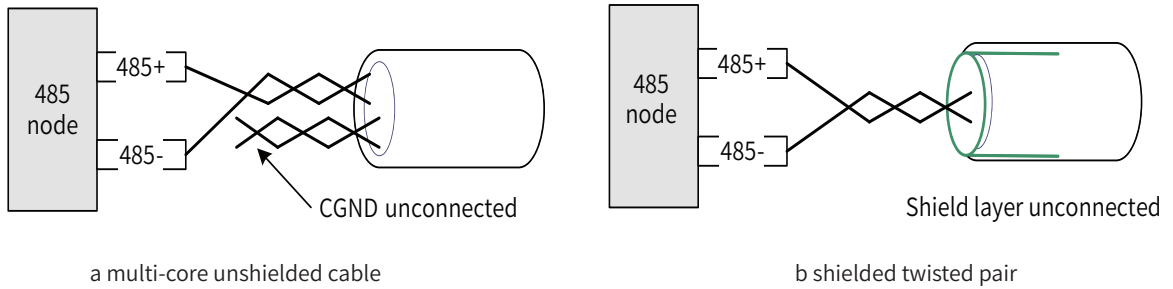

Figure 5-33 Connection for nodes without the CGND terminal

- 2) Method 1: Check whether other terminals of the node share a reference ground with the 485 circuit. If yes, connect the CGND cable or the shield layer of the bus to the corresponding pin.
- 3) Method 2: Find the reference ground of the 485 circuit on the board of the node and connect a cable from the reference ground to CGND cable or the shield layer.
- 4) Method 3: If you cannot find the reference ground of the 485 circuit, keep the CGND cable or shield layer unconnected, as shown in the preceding figure, and use an additional ground cable to connect the node to the PE terminal of other nodes.

■ Transmission distance and number of nodes

The maximum node count and transmission distance supported by the standard 485 circuit at different transmission rates are as follows:

No.	Transmission Rate	Transmission Distance	Number of Nodes	Cable Diameter
1	115.2 kbps	100 m	128	AWG26
2	19.2 kbps	1000 m	128	AWG26

5) Communication port introduction

As shown in the following figure, 2 RS485 ports (channels) share CN1 connector (DB9 type). The signal arrangement is as follows:

RS485 Port of the CPU Module		Pin	Channel	Definition	Function
	1	COM0 (RS485)	RS485-	Negative signal of the RS485 differential pair of COM0	
	2		RS485+	Positive signal of the RS485 differential pair of COM0	
	5		GND0	Power ground of COM0	
	6	COM1 (RS485)	RS485-	Negative signal of the RS485 differential pair of COM1	
	9		RS485+	Positive signal of the RS485 differential pair of COM1	
	3		GND1	Power ground of COM1	

- 6) Wiring (including cable preparation and wiring description. For details, see Section ["5.2 Selecting and Making Cables"](#).)

5.5.6 Monitoring Connection Through Ethernet

1) Wiring diagram

The Ethernet port of the CPU module can establish point-to-point connections to the PC and HMI through an Ethernet cable.

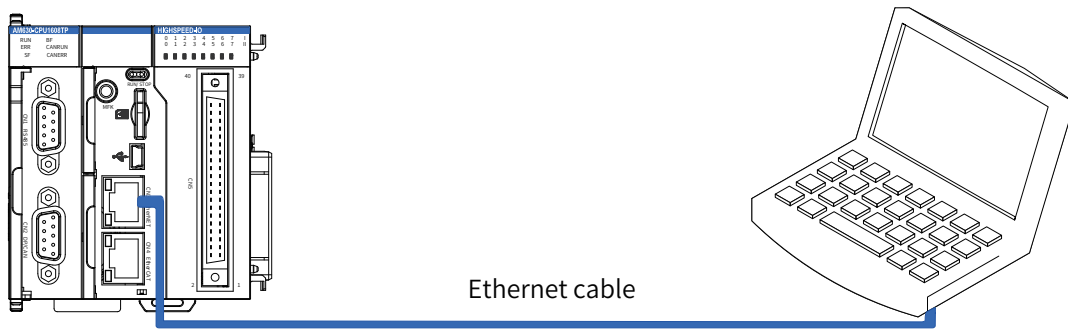

Figure 5-34 Connection between the CPU module and PC

It can also connect to a hub or switch through an Ethernet cable and then connect to other network devices through the hub or switch, achieving multi-point connections.

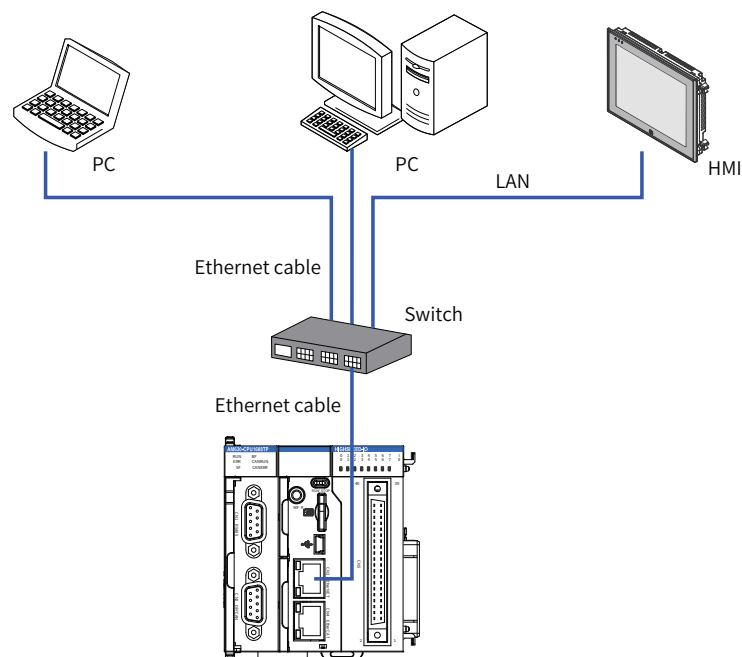

Figure 5-35 Connections between the CPU module and other devices through a switch

2) Wiring

To improve device communication reliability, use shielded twisted pair cables of Cat5e with steel-shell molding wires as the Ethernet cables.

5.6 Wiring of Local Expansion Modules

5.6.1 DI Modules

1) AM600-1600END/GL10-1600END DI module

■ Terminal arrangement and signal definitions (AM600-1600END)

DI module AM600-1600END					
Terminal Arrangement	No.	Terminal Symbol	Type	Function	Remarks
	Input Interface Group 1				
	1	I0	Input	User input 0 of group 1	Sink/Source input
	2	I1	Input	User input 1 of group 1	Sink/Source input
	3	I2	Input	User input 2 of group 1	Sink/Source input
	4	I3	Input	User input 3 of group 1	Sink/Source input
	5	I4	Input	User input 4 of group 1	Sink/Source input
	6	I5	Input	User input 5 of group 1	Sink/Source input
	7	I6	Input	User input 6 of group 1	Sink/Source input
	8	I7	Input	User input 7 of group 1	Sink/Source input
	Input Interface Group 2				
	9	I0	Input	User input 0 of group 2	Sink/Source input
	10	I1	Input	User input 1 of group 2	Sink/Source input
	11	I2	Input	User input 2 of group 2	Sink/Source input
	12	I3	Input	User input 3 of group 2	Sink/Source input
	13	I4	Input	User input 4 of group 2	Sink/Source input
	14	I5	Input	User input 5 of group 2	Sink/Source input
	15	I6	Input	User input 6 of group 2	Sink/Source input
	16	I7	Input	User input 7 of group 2	Sink/Source input
Common End Interfaces					
17	SS	Power	Common	-	
18	SS	Power	Common	-	

■ Wiring requirements (AM600-1600END)

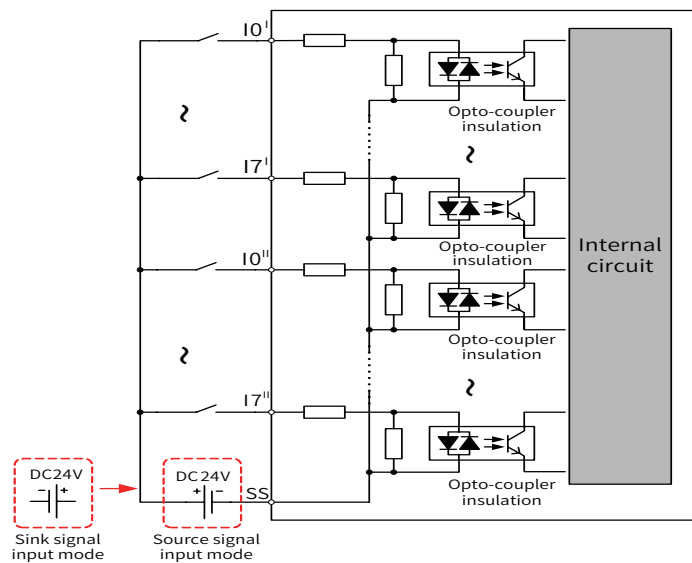

Figure 5-36 DI module AM600-1600END connection

2) AM600-3200END DI module

■ Terminal arrangement and signal definitions (AM600-3200END)

DI Module (AM600-3200END)						
Terminal Arrangement		Signal Definition				
		External Wiring	Signal Column B	Terminal No.	Signal Column A	Internal Circuit
		CH2 common terminal (SS2)	40	39	CH3 common terminal (SS3)	
		CH2 common terminal (SS2)	38	37	CH3 common terminal (SS3)	
		CH2-X7 (Ch2-I7)	36	35	CH3-X7 (Ch3-I7)	
		CH2-X6 (Ch2-I6)	34	33	CH3-X6 (Ch3-I6)	
		CH2-X5 (Ch2-I5)	32	31	CH3-X5 (Ch3-I5)	
		CH2-X4 (Ch2-I4)	30	29	CH3-X4 (Ch3-I4)	
		CH2-X3 (Ch2-I3)	28	27	CH3-X3 (Ch3-I3)	
		CH2-X2 (Ch2-I2)	26	25	CH3-X2 (Ch3-I2)	
		CH2-X1 (Ch2-I1)	24	23	CH3-X1 (Ch3-I1)	
		CH2-X0 (Ch2-I0)	22	21	CH3-X0 (Ch3-I0)	
		CH0 common terminal (SS0)	20	19	CH1 common terminal (SS1)	
		CH0 common terminal (SS0)	18	17	CH1 common terminal (SS1)	
		CH0-X7 (Ch0-I7)	16	15	CH1-X7 (Ch1-I7)	
		CH0-X6 (Ch0-I6)	14	13	CH1-X6 (Ch1-I6)	
		CH0-X5 (Ch0-I5)	12	11	CH1-X5 (Ch1-I5)	
		CH0-X4 (Ch0-I4)	10	9	CH1-X4 (Ch1-I4)	
		CH0-X3 (Ch0-I3)	8	7	CH1-X3 (Ch1-I3)	
		CH0-X2 (Ch0-I2)	6	5	CH1-X2 (Ch1-I2)	
		CH0-X1 (Ch0-I1)	4	3	CH1-X1 (Ch1-I1)	
		CH0-X0 (Ch0-I0)	2	1	CH1-X0 (Ch1-I0)	

The preceding table describes the internal circuit and external wiring of the port. Ensure that the wiring meets the corresponding requirements.

■ Wiring requirements (AM600-3200END)

If the SIRON T024-K connection terminals are used to connect the system wires, see the following figure for the relationship between the terminal numbers and the terminal pin numbers of the module (if other types of connection terminal blocks are used, confirm the relationship between the terminal numbers and the terminal pin numbers):

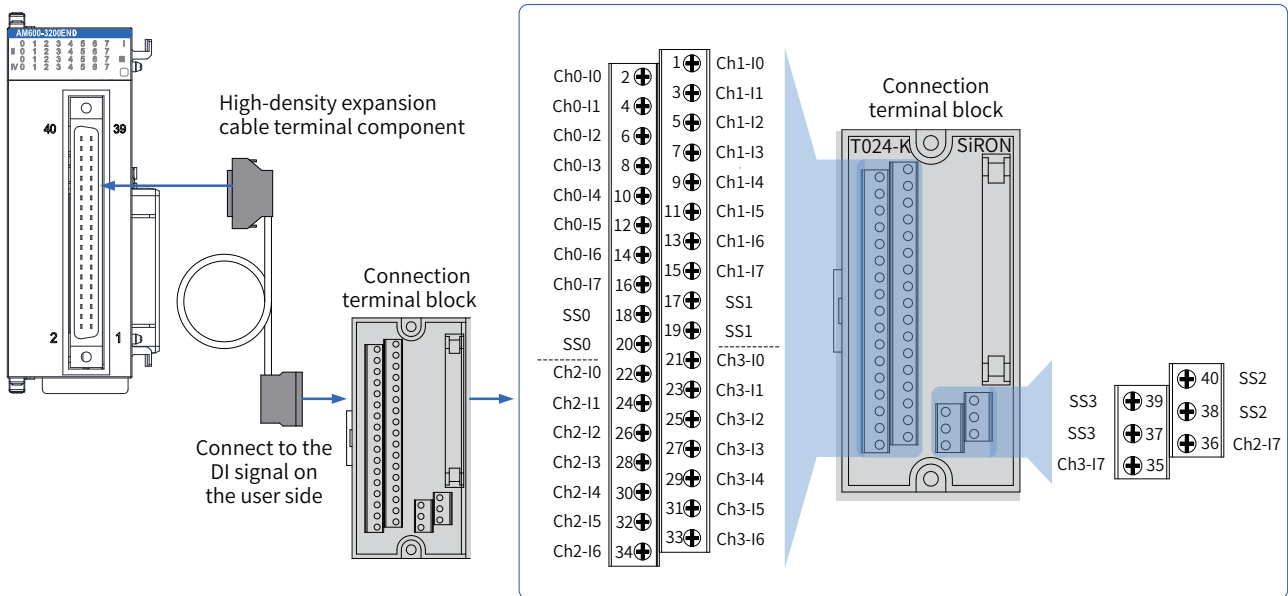

Figure 5-37 Wiring with SIRON T024-K connection terminal block

As shown in the preceding figure, Inovance provides the following items for customers to order:

- ① High-density extension cables; ② Connectors (used when you need to make cables);
- ③ Connection terminal block. The order information is as follows:

No.	Order Code	Description	Remarks
①	15300119	40-pin FCN to MIL cable (500 mm)	High-density connection cable, including a 40-pin FCN connector and a 40-pin MIL connector. Cable length: 500 mm
	15300193	40PIN FCN to MIL cable (2000 mm)	High-density connection cable, including a 40-pin FCN connector and a 40-pin MIL connector. Cable length: 2000 mm
②	15050180	40-pin FCN connector	You can purchase this connector to make cables yourself.
③	15020452	40-pin MIL to screw connection terminal block	

3) Wiring instructions

- Avoid binding extension cables with cables that generate strong interference, for example, power cables (high voltage and current), and avoid laying extension cables parallelly with those cables.
- Use the recommended cables and connection terminal block. You are advised to use shielded cables as extension cables to improve the interference resistance capability.

5.6.2 DO Modules

1 DO Modules AM600-0016ETP/GL10-0016ETP, AM600-0016ETN/GL10-0016ETN and AM600-0016ER/GL10-0016ER

■ Terminal signal arrangement and definitions (AM600-0016ETP)

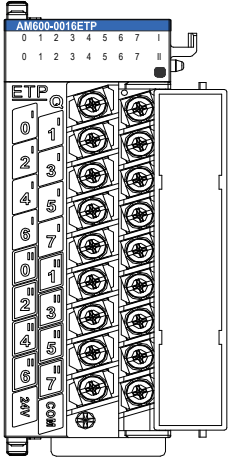
Transistor output module (AM600-0016ETP)					
Terminal Arrangement	No.	Terminal Symbol	Type	Function	Remarks
	Output interfaces of group 1				
	1	Q0	Output	User output 0 of group 1	Source output, active high
	2	Q1	Output	User output 1 of group 1	Source output, active high
	3	Q2	Output	User output 2 of group 1	Source output, active high
	4	Q3	Output	User output 3 of group 1	Source output, active high
	5	Q4	Output	User output 4 of group 1	Source output, active high
	6	Q5	Output	User output 5 of group 1	Source output, active high
	7	Q6	Output	User output 6 of group 1	Source output, active high
	8	Q7	Output	User output 7 of group 1	Source output, active high
	Output interfaces of group 2				
	9	Q0	Output	User output 0 of group 2	Source output, active high
	10	Q1	Output	User output 1 of group 2	Source output, active high
	11	Q2	Output	User output 2 of group 2	Source output, active high
	12	Q3	Output	User output 3 of group 2	Source output, active high
	13	Q4	Output	User output 4 of group 2	Source output, active high
	14	Q5	Output	User output 5 of group 2	Source output, active high
	15	Q6	Output	User output 6 of group 2	Source output, active high
	16	Q7	Output	User output 7 of group 2	Source output, active high
Power connector					
17	24 V	Power	24 V power supply	24 VDC power input	
18	COM	Power	Power ground	24 VDC power common	

■ Terminal signal arrangement and definitions (AM600-0016ETN)

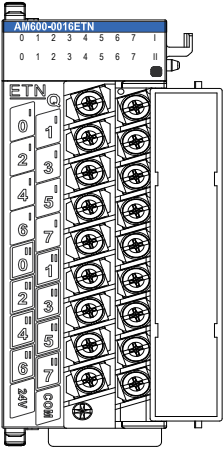
Transistor output module (AM600-0016ETN)					
Terminal Arrangement	No.	Terminal Symbol	Type	Function	Remarks
	Output interfaces of group 1				
	1	Q0	Output	User output 0 of group 1	Sink output, active low
	2	Q1	Output	User output 1 of group 1	Sink output, active low
	3	Q2	Output	User output 2 of group 1	Sink output, active low
	4	Q3	Output	User output 3 of group 1	Sink output, active low
	5	Q4	Output	User output 4 of group 1	Sink output, active low
	6	Q5	Output	User output 5 of group 1	Sink output, active low
	7	Q6	Output	User output 6 of group 1	Sink output, active low
	8	Q7	Output	User output 7 of group 1	Sink output, active low
	Output interfaces of group 2				
	9	Q0	Output	User output 0 of group 2	Sink output, active low
	10	Q1	Output	User output 1 of group 2	Sink output, active low
	11	Q2	Output	User output 2 of group 2	Sink output, active low
	12	Q3	Output	User output 3 of group 2	Sink output, active low
	13	Q4	Output	User output 4 of group 2	Sink output, active low
	14	Q5	Output	User output 5 of group 2	Sink output, active low
	15	Q6	Output	User output 6 of group 2	Sink output, active low
	16	Q7	Output	User output 7 of group 2	Sink output, active low
Power connector					
17	24 V	Power	24 V power supply	24 VDC power input	
18	COM	Power	Power ground	24 VDC power common	

■ Terminal signal arrangement and definitions (AM600-0016ER)

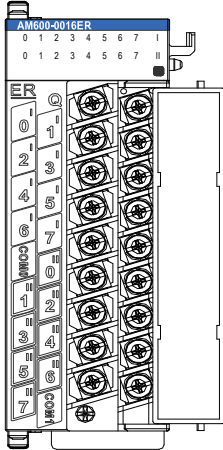
Relay output module (AM600-0016ER)					
Terminal Arrangement	No.	Terminal Symbol	Type	Function	Remarks
Output interfaces of group 1					
	1	Q0	Output	User output 0 of group 1	Sink output, active high
	2	Q1	Output	User output 1 of group 1	Sink output, active high
	3	Q2	Output	User output 2 of group 1	Sink output, active high
	4	Q3	Output	User output 3 of group 1	Sink output, active high
	5	Q4	Output	User output 4 of group 1	Sink output, active high
	6	Q5	Output	User output 5 of group 1	Sink output, active high
	7	Q6	Output	User output 6 of group 1	Sink output, active high
	8	Q7	Output	User output 7 of group 1	Sink output, active high
	9	COM0	Output common	Common	Common of the first group
Output interfaces of group 2					
10	Q0	Output	User output 0 of group 2	Sink output, active high	
11	Q1	Output	User output 1 of group 2	Sink output, active high	
12	Q2	Output	User output 2 of group 2	Sink output, active high	
13	Q3	Output	User output 3 of group 2	Sink output, active high	
14	Q4	Output	User output 4 of group 2	Sink output, active high	
15	Q5	Output	User output 5 of group 2	Sink output, active high	
16	Q6	Output	User output 6 of group 2	Sink output, active high	
17	Q7	Output	User output 7 of group 2	Sink output, active high	
18	COM1	Output common	Common	Common of the second group	
Power connector					
1	24 V	Power input	24 VDC power supply	24 VDC power input	
2	COM	Power supply common	Common	24 VDC power common	

■ External wiring (AM600-0016ETP/AM600-0016ETN/AM600-0016ER)

◆ Transistor outputs

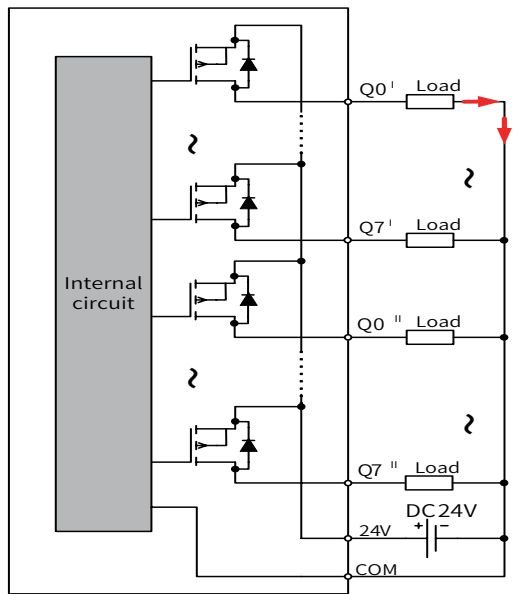

Figure 5-38 AM600-0016ETP output wiring

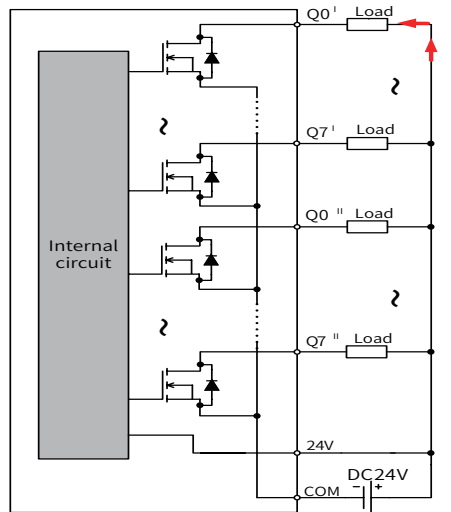

Figure 5-39 AM600-0016ETN outputs wiring

◆ Relay outputs

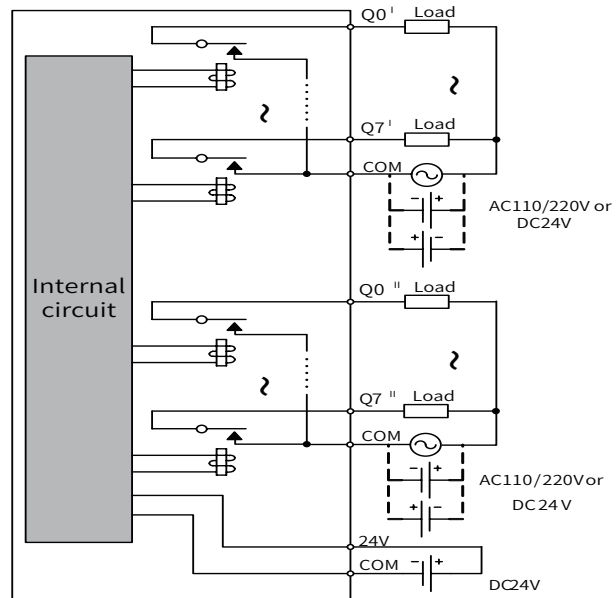

Figure 5-40 AM600-0016ER outputs wiring

2 DO module (AM600-0032ETN)

■ Terminal signal arrangement and definitions

Terminal Arrangement		Terminal Definition																																																																																																											
	<table border="1"> <thead> <tr> <th>External Wiring</th> <th>Signal Column B</th> <th colspan="2">Terminal No.</th> <th>Signal Column A</th> <th>Internal Circuit</th> </tr> </thead> <tbody> <tr> <td rowspan="10"> </td> <td>24 V power (24 V2)</td> <td>40</td> <td>39</td> <td>24 V power (24 V3)</td> <td>Internal power</td> </tr> <tr> <td>CH2 common terminal (COM2)</td> <td>38</td> <td>37</td> <td>CH3 common terminal (COM3)</td> <td>Isolation component</td> </tr> <tr> <td>CH2-Y7 (Ch2-Q7)</td> <td>36</td> <td>35</td> <td>CH3-Y7 (Ch3-Q7)</td> <td>Isolation component</td> </tr> <tr> <td>CH2-Y6 (Ch2-Q6)</td> <td>34</td> <td>33</td> <td>CH3-Y6 (Ch3-Q6)</td> <td>Isolation component</td> </tr> <tr> <td>CH2-Y5 (Ch2-Q5)</td> <td>32</td> <td>31</td> <td>CH3-Y5 (Ch3-Q5)</td> <td>Isolation component</td> </tr> <tr> <td>CH2-Y4 (Ch2-Q4)</td> <td>30</td> <td>29</td> <td>CH3-Y4 (Ch3-Q4)</td> <td>Isolation component</td> </tr> <tr> <td>CH2-Y3 (Ch2-Q3)</td> <td>28</td> <td>27</td> <td>CH3-Y3 (Ch3-Q3)</td> <td>Isolation component</td> </tr> <tr> <td>CH2-Y2 (Ch2-Q2)</td> <td>26</td> <td>25</td> <td>CH3-Y2 (Ch3-Q2)</td> <td>Isolation component</td> </tr> <tr> <td>CH2-Y1 (Ch2-Q1)</td> <td>24</td> <td>23</td> <td>CH3-Y1 (Ch3-Q1)</td> <td>Isolation component</td> </tr> <tr> <td>CH2-Y0 (Ch2-Q0)</td> <td>22</td> <td>21</td> <td>CH3-Y0 (Ch3-Q0)</td> <td>Isolation component</td> </tr> <tr> <td rowspan="10"> </td> <td>24 V power (24 V0)</td> <td>20</td> <td>19</td> <td>24 V power (24 V1)</td> <td>Internal power</td> </tr> <tr> <td>CH0 common terminal (COM0)</td> <td>18</td> <td>17</td> <td>CH1 common terminal (COM1)</td> <td>Isolation component</td> </tr> <tr> <td>CH0-Y7 (Ch0-Q7)</td> <td>16</td> <td>15</td> <td>CH1-Y7 (Ch1-Q7)</td> <td>Isolation component</td> </tr> <tr> <td>CH0-Y6 (Ch0-Q6)</td> <td>14</td> <td>13</td> <td>CH1-Y6 (Ch1-Q6)</td> <td>Isolation component</td> </tr> <tr> <td>CH0-Y5 (Ch0-Q5)</td> <td>12</td> <td>11</td> <td>CH1-Y5 (Ch1-Q5)</td> <td>Isolation component</td> </tr> <tr> <td>CH0-Y4 (Ch0-Q4)</td> <td>10</td> <td>9</td> <td>CH1-Y4 (Ch1-Q4)</td> <td>Isolation component</td> </tr> <tr> <td>CH0-Y3 (Ch0-Q3)</td> <td>8</td> <td>7</td> <td>CH1-Y3 (Ch1-Q3)</td> <td>Isolation component</td> </tr> <tr> <td>CH0-Y2 (Ch0-Q2)</td> <td>6</td> <td>5</td> <td>CH1-Y2 (Ch1-Q2)</td> <td>Isolation component</td> </tr> <tr> <td>CH0-Y1 (Ch0-Q1)</td> <td>4</td> <td>3</td> <td>CH1-Y1 (Ch1-Q1)</td> <td>Isolation component</td> </tr> <tr> <td>CH0-Y0 (Ch0-Q0)</td> <td>2</td> <td>1</td> <td>CH1-Y0 (Ch1-Q0)</td> <td>Isolation component</td> </tr> </tbody> </table>	External Wiring	Signal Column B	Terminal No.		Signal Column A	Internal Circuit		24 V power (24 V2)	40	39	24 V power (24 V3)	Internal power	CH2 common terminal (COM2)	38	37	CH3 common terminal (COM3)	Isolation component	CH2-Y7 (Ch2-Q7)	36	35	CH3-Y7 (Ch3-Q7)	Isolation component	CH2-Y6 (Ch2-Q6)	34	33	CH3-Y6 (Ch3-Q6)	Isolation component	CH2-Y5 (Ch2-Q5)	32	31	CH3-Y5 (Ch3-Q5)	Isolation component	CH2-Y4 (Ch2-Q4)	30	29	CH3-Y4 (Ch3-Q4)	Isolation component	CH2-Y3 (Ch2-Q3)	28	27	CH3-Y3 (Ch3-Q3)	Isolation component	CH2-Y2 (Ch2-Q2)	26	25	CH3-Y2 (Ch3-Q2)	Isolation component	CH2-Y1 (Ch2-Q1)	24	23	CH3-Y1 (Ch3-Q1)	Isolation component	CH2-Y0 (Ch2-Q0)	22	21	CH3-Y0 (Ch3-Q0)	Isolation component		24 V power (24 V0)	20	19	24 V power (24 V1)	Internal power	CH0 common terminal (COM0)	18	17	CH1 common terminal (COM1)	Isolation component	CH0-Y7 (Ch0-Q7)	16	15	CH1-Y7 (Ch1-Q7)	Isolation component	CH0-Y6 (Ch0-Q6)	14	13	CH1-Y6 (Ch1-Q6)	Isolation component	CH0-Y5 (Ch0-Q5)	12	11	CH1-Y5 (Ch1-Q5)	Isolation component	CH0-Y4 (Ch0-Q4)	10	9	CH1-Y4 (Ch1-Q4)	Isolation component	CH0-Y3 (Ch0-Q3)	8	7	CH1-Y3 (Ch1-Q3)	Isolation component	CH0-Y2 (Ch0-Q2)	6	5	CH1-Y2 (Ch1-Q2)	Isolation component	CH0-Y1 (Ch0-Q1)	4	3	CH1-Y1 (Ch1-Q1)	Isolation component	CH0-Y0 (Ch0-Q0)	2	1	CH1-Y0 (Ch1-Q0)	Isolation component
		External Wiring	Signal Column B	Terminal No.		Signal Column A	Internal Circuit																																																																																																						
			24 V power (24 V2)	40	39	24 V power (24 V3)	Internal power																																																																																																						
			CH2 common terminal (COM2)	38	37	CH3 common terminal (COM3)	Isolation component																																																																																																						
			CH2-Y7 (Ch2-Q7)	36	35	CH3-Y7 (Ch3-Q7)	Isolation component																																																																																																						
			CH2-Y6 (Ch2-Q6)	34	33	CH3-Y6 (Ch3-Q6)	Isolation component																																																																																																						
			CH2-Y5 (Ch2-Q5)	32	31	CH3-Y5 (Ch3-Q5)	Isolation component																																																																																																						
			CH2-Y4 (Ch2-Q4)	30	29	CH3-Y4 (Ch3-Q4)	Isolation component																																																																																																						
			CH2-Y3 (Ch2-Q3)	28	27	CH3-Y3 (Ch3-Q3)	Isolation component																																																																																																						
			CH2-Y2 (Ch2-Q2)	26	25	CH3-Y2 (Ch3-Q2)	Isolation component																																																																																																						
			CH2-Y1 (Ch2-Q1)	24	23	CH3-Y1 (Ch3-Q1)	Isolation component																																																																																																						
			CH2-Y0 (Ch2-Q0)	22	21	CH3-Y0 (Ch3-Q0)	Isolation component																																																																																																						
			24 V power (24 V0)	20	19	24 V power (24 V1)	Internal power																																																																																																						
			CH0 common terminal (COM0)	18	17	CH1 common terminal (COM1)	Isolation component																																																																																																						
			CH0-Y7 (Ch0-Q7)	16	15	CH1-Y7 (Ch1-Q7)	Isolation component																																																																																																						
			CH0-Y6 (Ch0-Q6)	14	13	CH1-Y6 (Ch1-Q6)	Isolation component																																																																																																						
			CH0-Y5 (Ch0-Q5)	12	11	CH1-Y5 (Ch1-Q5)	Isolation component																																																																																																						
			CH0-Y4 (Ch0-Q4)	10	9	CH1-Y4 (Ch1-Q4)	Isolation component																																																																																																						
			CH0-Y3 (Ch0-Q3)	8	7	CH1-Y3 (Ch1-Q3)	Isolation component																																																																																																						
			CH0-Y2 (Ch0-Q2)	6	5	CH1-Y2 (Ch1-Q2)	Isolation component																																																																																																						
CH0-Y1 (Ch0-Q1)	4		3	CH1-Y1 (Ch1-Q1)	Isolation component																																																																																																								
CH0-Y0 (Ch0-Q0)	2		1	CH1-Y0 (Ch1-Q0)	Isolation component																																																																																																								

The preceding table describes the internal circuit and external wiring of the port. Ensure that the wiring meets the corresponding requirements.

If the SIRON T024-K connection terminals are used to connect the system wires, see the following figure for the relationship between the terminal numbers and the terminal pin numbers of the module (if other types of connection terminal blocks are used, confirm the relationship between the terminal numbers and the terminal pin numbers):

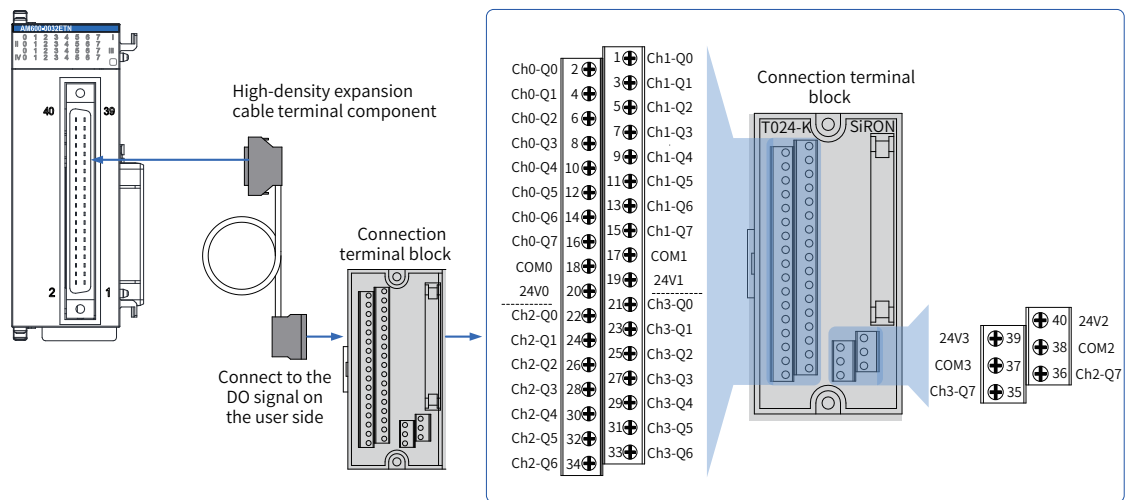

Figure 5-41 Wiring with SIRON T024-K connection terminal block

As shown in the preceding figure, Inovance provides the following items for customers to order:

- ① High-density extension cables;
- ② Connectors (used when you need to make cables);
- ③ Connection terminal block. The order information is as follows:

No.	Order Code	Description	Remarks
①	15300119	40-pin FCN to MIL cable (500 mm)	High-density extension cable, including a 40-pin FCN connector and an MIL connector.
	15300193	40PIN FCN to MIL cable (2000 mm)	
②	15050180	40-pin FCN connector	You can purchase this connector to make cables yourself.
③	15020452	40-pin MIL to screw connection terminal block	

4) Wiring instructions

- Avoid binding extension cables with cables that generate strong interference, for example, power cables (high voltage and current), and avoid laying extension cables parallelly with those cables.
- Use the recommended cables and connection terminal block. You are advised to use shielded cables as extension cables to improve the interference resistance capability.
- Electric shock protection when inductive load is used:

If inductive load is connected, it generates a strong reverse electromotive force (EMF) between contact points and electric arc discharge when the contact opens, causing contact failure at the contact points or contact point sinking and shortening the service life. To avoid this problem, add a parallel flywheel diode to the load when necessary. The diode must meet the following requirements:

- ① Reverse voltage: 5 to 10 times of the load voltage;
- ② Forward current: greater than the load current

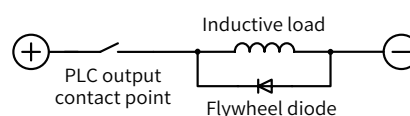

Figure 5-42 Electric shock protection when inductive load is used





- Electric shock protection when capacitive load is used:

The outputs of this module cannot be connected to large capacitive loads. Otherwise, false faults may be reported when the channel is closed.

5.6.3 AI Module

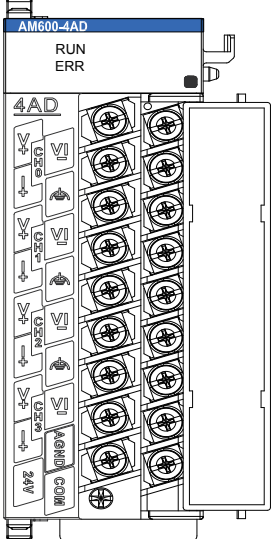
1 AI module AM600-4AD/GL10-4AD

1) Terminal signal arrangement and definitions (AM600-4AD)

AI Module AM600-4AD					
Terminal Arrangement	No.	Terminal Symbol	Type	Function	Remarks
	1	V+	Input	V+ of channel 0	Voltage input
	2	VI-	Input	V-/I- of channel 0	Voltage/Current input
	3	I+	Input	I+ of channel 0	Current Input
	4		-	Shielding ground	Internally connected to housing ground
	5	V+	Input	V+ of channel 1	Voltage input
	6	VI-	Input	V-/I- of channel 1	Voltage/Current input
	7	I+	Input	I+ of channel 1	Current Input
	8		-	Shielding ground	Internally connected to housing ground
	9	V+	Input	V+ of channel 2	Voltage input
	10	VI-	Input	V-/I- of channel 2	Voltage/Current input
	11	I+	Input	I+ of channel 2	Current Input
	12		-	Shielding ground	Internally connected to housing ground
	13	V+	Input	V+ of channel 3	Voltage input
	14	VI-	Input	V-/I- of channel 3	Voltage/Current input
	15	I+	Input	I+ of channel 3	Current Input
	16	AGND	Analog ground	Analog ground	-
	17	24 V	Power	24 V power supply	-
	18	COM	Power ground	Power ground	-

2) External wiring

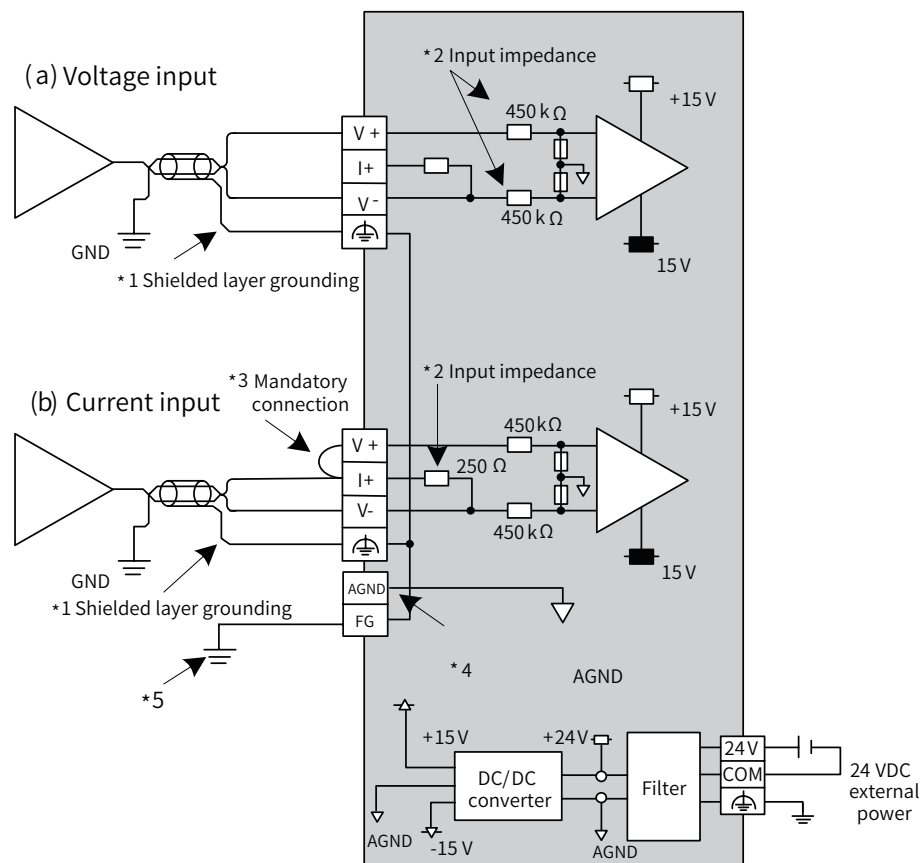

Figure 5-43 AO module wiring



NOTE

- ◆ *1 Use 2-core shielded twisted pair cable for analog signal.
- ◆ *2 Indicates input impedance of 4AD module.
- ◆ *3 For current input (4 to 20 mA, 0 to 20 mA), terminal (V+) must be connected to terminal (I+).
- ◆ *4 When the input signal is a differential signal, "AGND" can be connected to analog ground of compatible devices to eliminate the difference of common mode voltage between devices and ensure the accuracy of module sampling.
- ◆ *5 The module must be mounted on a well-grounded metal bracket, and ensure that the metal spring plate at the bottom of the module is in good contact with the bracket.

3) Wiring instructions

- Do not bind the cable together with AC cable, main lines, high voltage cable and so forth; otherwise, increased noise, surge, and induction may be caused.
- Apply single-point grounding for the shielding of shielded cables and solder sealed cable.
- Tubed and solderless crimp terminal cannot be used with the terminal blocks. Using marking sleeve or insulation sleeve to cover the cable connector part of the crimp terminals is recommended.

5.6.4 AO Module

1 AO module AM600-4DA/GL10-4DA

1) Terminal signal arrangement and definitions (AM600-4DA)

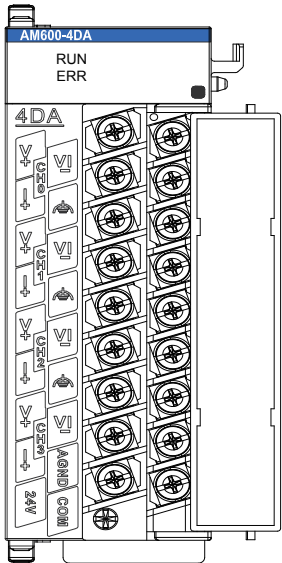
AO Module AM600-4DA					
Terminal Arrangement	No.	Terminal Symbol	Type	Function	Remarks
	1	V+	Output	V+ of channel 0	Voltage output
	2	VI-	Output	V-/I- of channel 0	Voltage/Current output
	3	I+	Output	I+ of channel 0	Current output
	4		-	Shielding ground	Internally connected to housing ground
	5	V+	Output	V+ of channel 1	Voltage output
	6	VI-	Output	V-/I- of channel 1	Voltage/Current output
	7	I+	Output	I+ of channel 1	Current output
	8		-	Shielding ground	Internally connected to housing ground
	9	V+	Output	V+ of channel 2	Voltage output
	10	VI-	Output	V-/I- of channel 2	Voltage/Current output
	11	I+	Output	I+ of channel 2	Current output
	12		-	Shielding ground	Internally connected to housing ground
	13	V+	Output	V+ of channel 3	Voltage output
	14	VI-	Output	V-/I- of channel 3	Voltage/Current output
	15	I+	Output	I+ of channel 3	Current output
	16	AGND	Analog signal ground	Analog signal ground	-
	17	24 V	Power	24 V power supply	-
	18	COM	Power ground	Power ground	-

2) External wiring

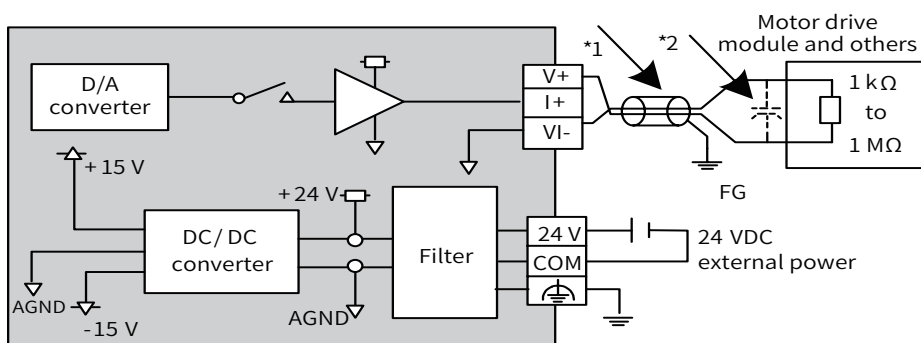

Figure 5-44 Connection for voltage control signal



- ◆ *1 Use 2-core shielded twisted pair cable.
- ◆ *2 If noise or ripple is generated in external wiring, connect a capacitor of 0.1 to 0.47 mF 25 V between terminals V+/I+ and VI-.

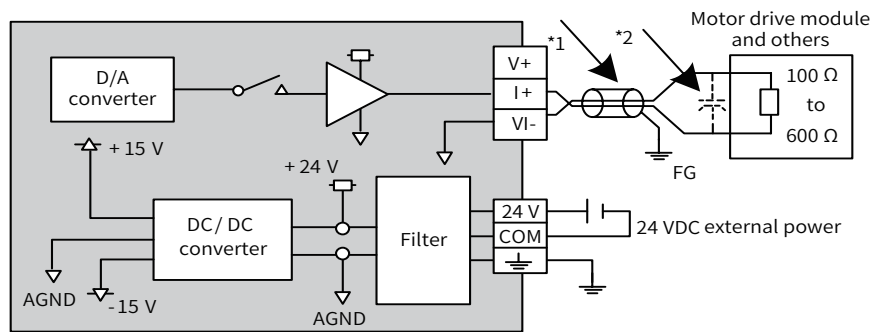

Figure 5-45 Connection for current-control signal



NOTE

- ◆ *1 Use 2-core shielded twisted pair cable.
- ◆ *2 If noise or ripple is generated in external wiring, connect a capacitor of 0.1 to 0.47 mF 25 V between terminals V+/I+ and VI-.

3) Wiring instructions

- Do not bind the cable together with AC cable, main lines, high voltage cable and so forth; otherwise, increased noise, surge, and induction may be caused.
- Apply single-point grounding for the shielding of shielded cable and solder sealed cable.
- Tubed and solderless crimp terminal cannot be used with the terminal blocks. Using marking sleeve or insulation sleeve to cover the cable connector part of the crimp terminals is recommended.

5.6.5 Temperature Detection Modules

1 Terminal arrangement and signal definitions of the temperature detection module (AM600-4PT/GL10-4PT)

1) Terminal arrangement and signal definitions

Terminal Arrangement	Terminal Symbol	Type	Function	Terminal No.	
	IN0 A	Input	Temperature measuring resistor A of channel 0	1	
	IN0 B	Input	Temperature measuring resistor B of channel 0	3	
	IN0 b	Input	Temperature measuring resistor b of channel 0	5	
	IN1 A	Input	Temperature measuring resistor A of channel 1	2	
	IN1 B	Input	Temperature measuring resistor B of channel 1	4	
	IN1 b	Input	Temperature measuring resistor b of channel 1	6	
	IN2 A	Input	Temperature measuring resistor A of channel 2	9	
	IN2 B	Input	Temperature measuring resistor B of channel 2	11	
	IN2 b	Input	Temperature measuring resistor b of channel 2	13	
	IN3 A	Input	Temperature measuring resistor A of channel 3	10	
	IN3 B	Input	Temperature measuring resistor B of channel 3	12	
	IN3 b	Input	Temperature measuring resistor b of channel 3	14	
	NC	Reserved	Reserved		7
	NC			8	
	NC			15	
	NC			16	
	24 V	Power	+24 V power supply		17
	COM	Power	24 V power ground		18

2) External wiring

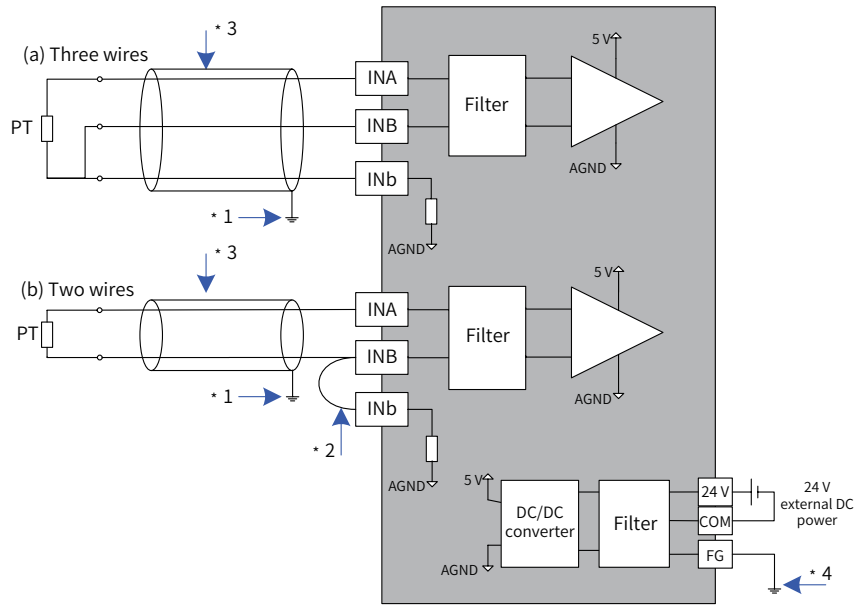

Figure 5-46 AM600-4PT module wiring



NOTE

- ◆ *1 Use shielded cables.
- ◆ *2 If two-wire connection is used, the INB and INb channels need to be shorted, and the cable resistance affects the measurement.
- ◆ *3 Use cables with small wire resistance and without resistance difference between the three wires.
- ◆ *4 The module should be mounted on a well-grounded metal bracket, and ensure that the spring plate shrapnel at the bottom of the module is in good contact with the bracket.

2 Terminal arrangement and signal definitions of the temperature detection modules AM600-8TC/GL10-8TC) and AM600-4TC/GL10-4TC

- The following table describes the terminals of the AM600-8TC temperature detection module. The L4 +/L4- ~L7+/ L7- terminals of the AM600-4TC temperature detection module are reserved.

Terminal Arrangement	Terminal Symbol	Type	Function	Terminal No.
	L0+	Input	Thermocouple of channel 0	1
	L0-	Input	Thermocouple of channel 0	2
	L1+	Input	Thermocouple of channel 1	3
	L1-	Input	Thermocouple of channel 1	4
	L2+	Input	Thermocouple of channel 2	5
	L2-	Input	Thermocouple of channel 2	6
	L3+	Input	Thermocouple of channel 3	7
	L3-	Input	Thermocouple of channel 3	8
	L4+	Input	Thermocouple of channel 4	9
	L4-	Input	Thermocouple of channel 4	10
	L5+	Input	Thermocouple of channel 5	11
	L5-	Input	Thermocouple of channel 5	12
	L6+	Input	Thermocouple of channel 6	13
	L6-	Input	Thermocouple of channel 6	14
	L7+	Input	Thermocouple of channel 7/external cold-side compensation (for high-accuracy external cold-side compensation)	15
	L7-	Input	Thermocouple of channel 7/external cold-side compensation (for high-accuracy external cold-side compensation)	16
	+24V	Power	+24 V power supply	17
	COM	Power	24 V power ground	18

Note 1: For AM600-4TC, the L4+/L4~L7+/L7- channels are reserved.

Note 2: For AM600-8TC, the L7 sampling channel is used for compatibility which supports normal thermocouple sampling and external cold-side compensation. When the cold side of the thermocouple is far from the module, and the temperature difference is large, use the channel for external cold-side compensation if the requirement on temperature accuracy is high. In this case, you need to connect the PT100 thermal resistor for compensation, and only CH0 to CH6 of the module are used for TC sampling.

External wiring

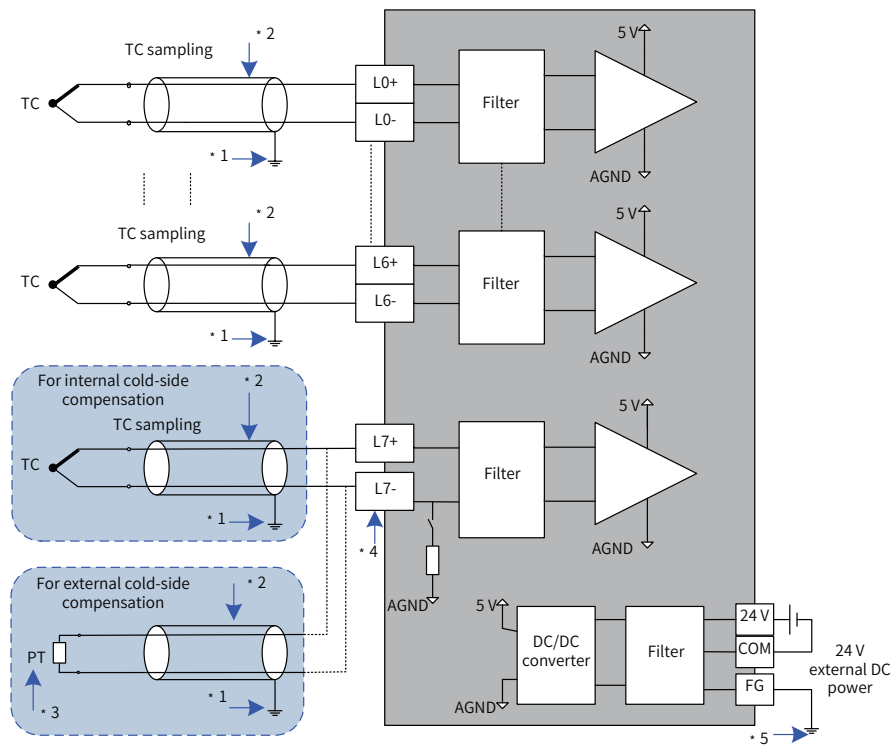

Figure 5-47 AM600-8TC module wiring



NOTE

- ◆ *1 Use shielded compensation wires.
- ◆ *2 If the distance is large between cold-side compensation and thermocouple end, and no compensation wire is used, the temperature measurement is abnormal.
- ◆ *3 Channel L7 can use PT100 thermal resistors for cold-side compensation, and you need to use the software to enable this channel.
- ◆ *4 If the module uses internal cold-side compensation, the L7 channel can be used for normal thermocouple sampling, and the wiring is as shown in L0 - L6 in the preceding figure; if the module uses external cold-side compensation, you need to connect the PT100 thermal resistor to the L7 channel, and the wiring is as shown in L7 in the preceding figure.
- ◆ *5 The module must be mounted on a well-grounded metal bracket, and ensure that the metal spring plate at the bottom of the module is in good contact with the bracket.

5.7 Wiring of Remote Expansion Modules (EtherCAT)

5.7.1 EtherCAT Wiring Requirements

- Network cable specifications

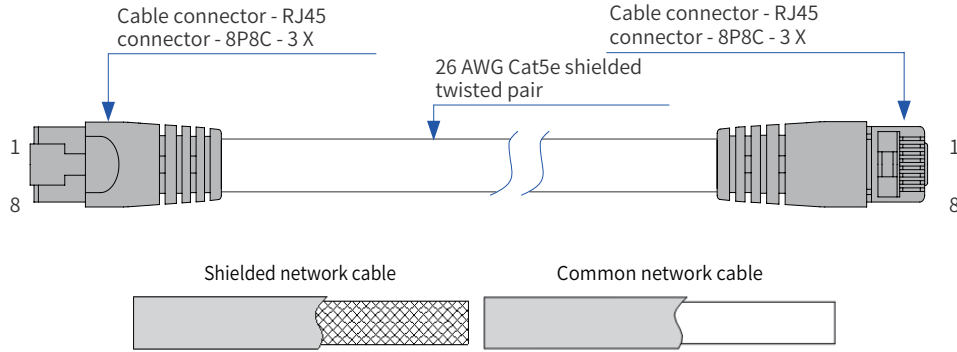

Figure 5-48 Network cable specifications

- Use Cat5e shielded twisted pair cable with steel-shell molding wires.

- Signal lead arrangement

Pin	Signal	Signal Direction	Signal Description
1	TD+	Output	Data transmission +
2	TD-	Output	Data transmission -
3	RD+	Input	Data reception +
4	--	--	Not in use
5	--	--	Not in use
6	RD-	Input	Data reception -
7	--	--	Not in use
8	--	--	Not in use

- Length requirement

The FastEthernet technology has proved that the cable length between devices cannot exceed 100 m when the EtherCAT bus is used. Otherwise, signal attenuation occurs, adversely affecting communication.

- Technical requirements

No short circuit, circuit break, misplacement, or poor contact is detected in the 100% conduction test.

The EtherCAT bus transfers network data through a shielded cable. The following network cable is recommended:

Item	Specifications
Cable type	Elastic crossover cable, S-FTP, Cat5e
Standards	EIA/TIA568A, EN50173, ISO/IEC11801 EIA/TI Abulletin TSB, and EIA/TIA SB40-A&TSB36
Wire type	Twisted pair
Number of pairs	4

■ Communication connection

Hold the RJ45 connector (with a cable) and insert it to the EtherCAT socket of the communication module until it clicks.

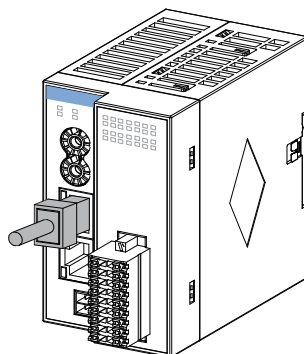

Figure 5-49 Communication connection

■ Communication cable fixing requirement

To prevent communication cables from being affected by mechanical forces and ensure communication stability, fix the cables close to the device before starting to use this module, as shown in the following figure:

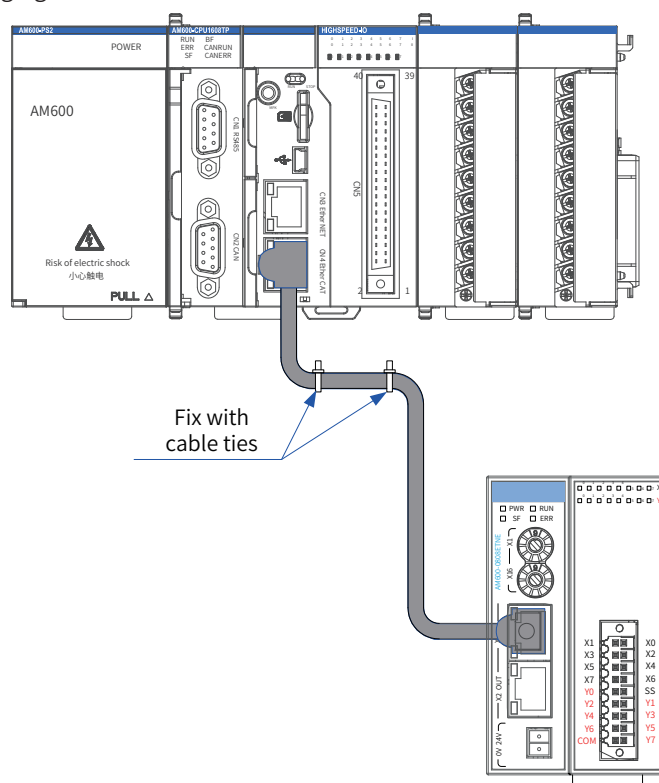

Figure 5-50 Fixing the communication cable

■ Slave station module fault indication and solutions for EtherCAT communication

LED Indicator	Description	Solution
RUN	Off	The EtherCAT master and slave stations are in initialization state. Check the configuration and parameter settings. Check the communication address. Check whether the network cable specifications and length meet the requirements.
	Blinking	The EtherCAT slave station is not in OP state. Check the slave station configuration and check whether any module is lost or faulty and whether any module without configuration exists.

LED Indicator		Description	Solution
ERR	Blinking	An error occurs in communication between the EtherCAT master station and the EtherCAT slave station.	Check whether the parameter settings are correct at the master and slave stations.
SF	Remaining on	The output channel is faulty.	Check whether short circuit or overtemperature has occurred in the output channel.

5.7.2 Wiring Requirements for User Terminal Output Signals

■ Cable selection

Cable Lug	American standard/AWG	Crimping Plier
Tubular lug	21	YAC-5

The preceding lug is applicable to the AM600-0808ETNE module, and the rated temperature of the cable must be higher than 75°C . The procedure for making a cable is as follows:

- 1) Peel off the insulation layer by 11 mm to 14 mm and pass the cable through a cable marker sleeve.
- 2) Insert the exposed end of the cable into the round hole of the lug and use the recommended crimping plier to crimp the hole.

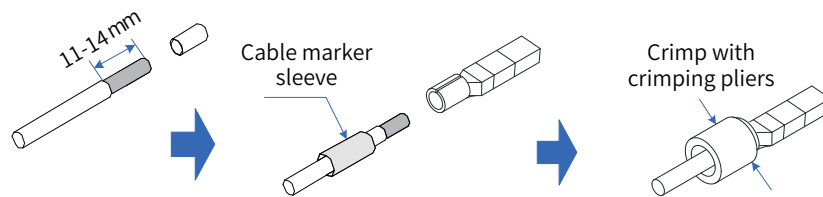
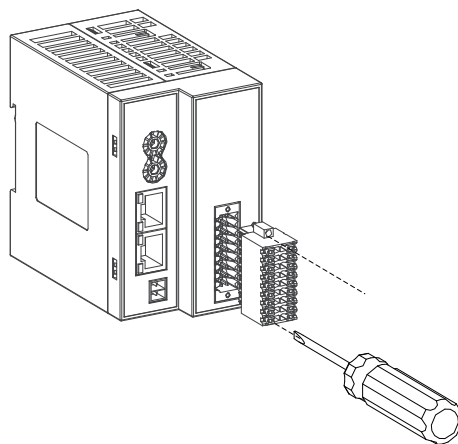

Figure 5-51 Making a cable

■ Wiring instructions

After the I/O terminal block is installed on CN5, use torque of 0.2 Nm to 0.25 Nm to tighten it, as shown in the following figure:



Avoid binding cables with cables that generate strong interference, for example, power cables (high voltage and current), and avoid laying cables parallelly with those cables when laying terminal wiring cables. Use the recommended cables. You are advised to use shielded cables as terminal wiring cables to improve the interference resistance capability.

5.7.3 Signal Wiring of the I/O Modules

1 AM600-0808ETNE/GR10-0808ETNE module

■ Terminal arrangement

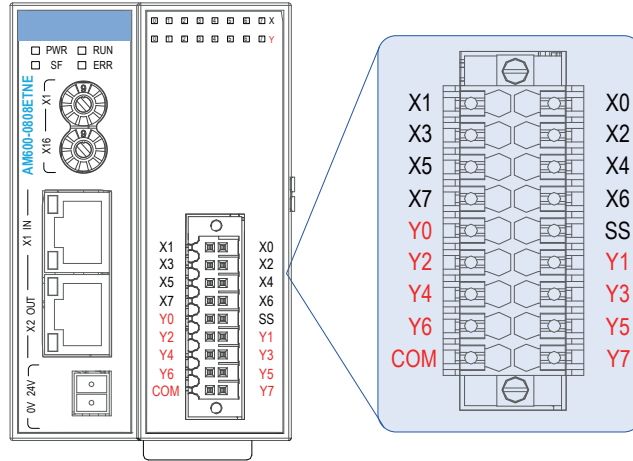
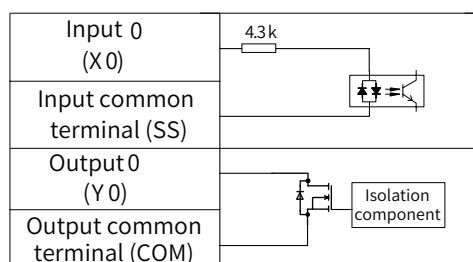

Figure 5-52 Terminal signal arrangement

■ External wiring

External Wiring	Signal	Terminal No.		Signal	External Wiring
	Column B			Column A	
	Input common terminal				
	Input 1 (X1)	2	1	Input 0 (X0)	
	Input 3 (X3)	4	3	Input 2 (X2)	
	Input 5 (X5)	6	5	Input 4 (X4)	
	Input 7 (X7)	8	7	Input 6 (X6)	
	Output 0 (Y0)	10	9	Input common terminal (SS)	
	Output 2 (Y2)	12	11	Output 1 (Y1)	
Output 4 (Y4)	14	13	Output 3 (Y3)		
Output 6 (Y6)	16	15	Output 5 (Y5)		
Output public terminal (COM)	18	17	Output 7 (Y7)		
				Output common terminal	

Internal equivalent circuit:



2 AM600-1616ETNE/GR10-1616ETNE module

■ Terminal arrangement

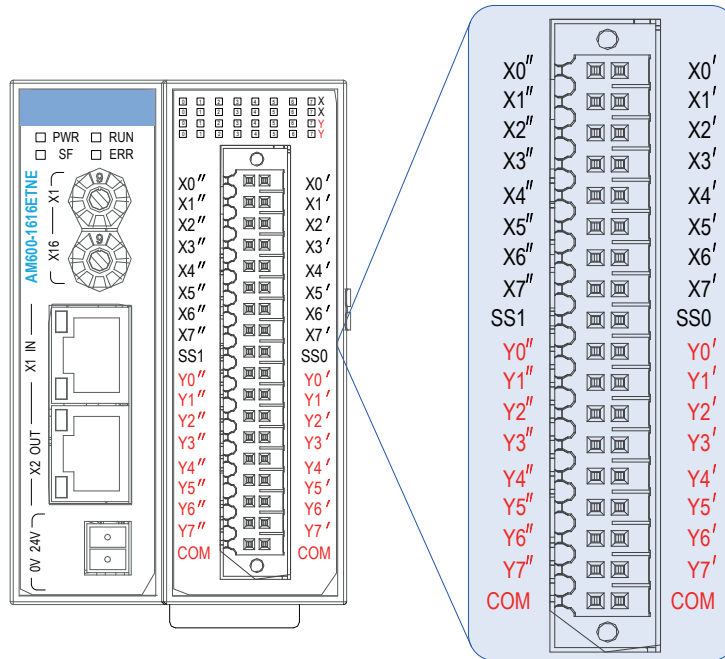
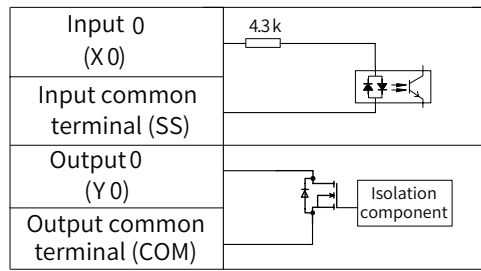

Figure 5-53 Terminal signal arrangement

■ External wiring

External Wiring	Signal	Terminal No.	Signal	External Wiring
	Column B		Column A	
	CH1 input 0 (CH1-X0)	2	1	CH0 input 0 (CH0-X0)
	CH1 input 1 (CH1-X1)	4	3	CH0 input 1 (CH0-X1)
	CH1 input 2 (CH1-X2)	6	5	CH0 input 2 (CH0-X2)
	CH1 input 3 (CH1-X3)	8	7	CH0 input 3 (CH0-X3)
	CH1 input 4 (CH1-X4)	10	9	CH0 input 4 (CH0-X4)
	CH1 input 5 (CH1-X5)	12	11	CH0 input 5 (CH0-X5)
	CH1 input 6 (CH1-X6)	14	13	CH0 input 6 (CH0-X6)
	CH1 input 7 (CH1-X7)	16	15	CH0 input 7 (CH0-X7)
	CH1 common terminal (SS1)	18	17	CH0 common terminal (SS0)
	CH1 output 0 (CH1-Y0)	20	19	CH0 output 0 (CH0-Y0)
	CH1 output 1 (CH1-Y1)	22	21	CH0 output 1 (CH0-Y1)
	CH1 output 2 (CH1-Y2)	24	23	CH0 output 2 (CH0-Y2)
	CH1 output 3 (CH1-Y3)	26	25	CH0 output 3 (CH0-Y3)
	CH1 output 4 (CH1-Y4)	28	27	CH0 output 4 (CH0-Y4)
	CH1 output 5 (CH1-Y5)	30	29	CH0 output 5 (CH0-Y5)
	CH1 output 6 (CH1-Y6)	32	31	CH0 output 6 (CH0-Y6)
CH1 output 7 (CH1-Y7)	34	33	CH0 output 7 (CH0-Y7)	
	CH1 common terminal (COM)	36	35	CH0 common terminal (COM)

■ Internal equivalent circuit



5.7.4 Signal Wiring of the High-speed Counting Module

1 AM600-2HCE/GR10-2HCE module

■ Terminal arrangement

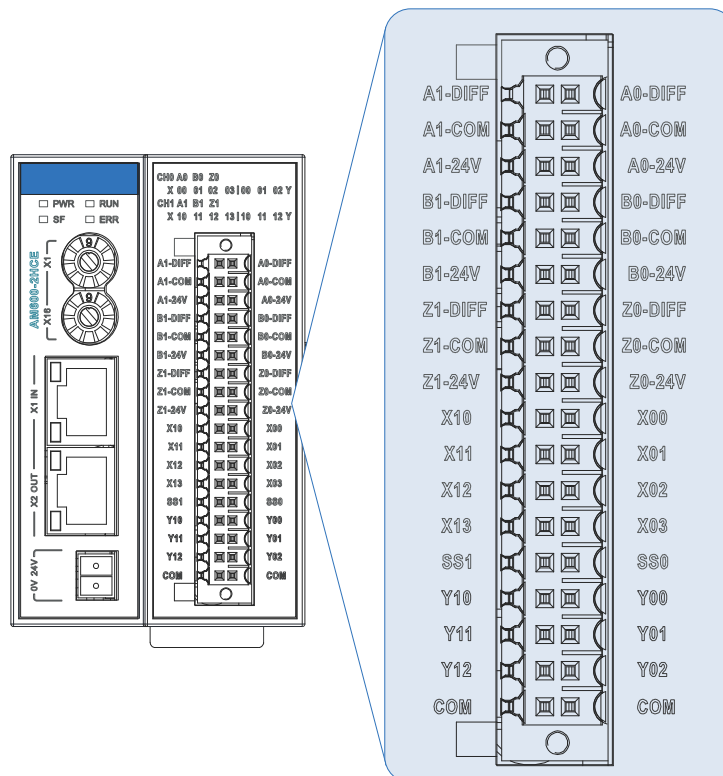
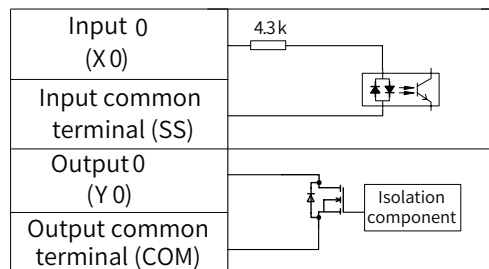

Figure 5-54 Terminal signal arrangement of the AM600-2HCE

■ External wiring

External Wiring	Signal	Terminal No.		Signal	External Wiring
	Column B			Column A	
	High-speed differential input (A1-DIFF)	2	1	High-speed differential input (A0-DIFF)	
	High-speed input common terminal (A1-COM)	4	3	High-speed input common terminal (A0-COM)	
	High-speed 24 V input (A1-24 V)	6	5	High-speed 24 V input (A0-24 V)	
	High-speed differential input (B1-DIFF)	8	7	High-speed differential input (B0-DIFF)	
	High-speed input common terminal (B1-COM)	10	9	High-speed input common terminal (B0-COM)	
	High-speed 24 V input (B1-24 V)	12	11	High-speed 24 V input (B0-24 V)	
	High-speed differential input (Z1-DIFF)	14	13	High-speed differential input (Z0-DIFF)	
	High-speed input common terminal (Z1-COM)	16	15	High-speed input common terminal (Z0-COM)	
	High-speed 24 V input (Z1-24 V)	18	17	High-speed 24 V input (Z0-24 V)	
	Standard input (X10 probe 1)	20	19	Standard input (X00 probe 1)	
	Standard input (X11 probe 2)	22	21	Standard input (X01 probe 2)	
	Standard input (X12 common input)	24	23	Standard input (X02 common input)	
	Standard input (X13 common input)	26	25	Standard input (X03 common input)	
	Input common terminal (SS1)	28	27	Input common terminal (SS0)	
	Output (Y10 high-speed comparing output 1)	30	29	Output (Y00 high-speed comparing output 1)	
	Output (Y11 high-speed comparing output 2)	32	31	Output (Y01 high-speed comparing output 2)	
	Output (Y12 common output)	34	33	Output (Y02 common output)	
	Output common terminal (COM)	3	6	Output common terminal (COM)	

■ Internal equivalent circuit



■ Signal connections

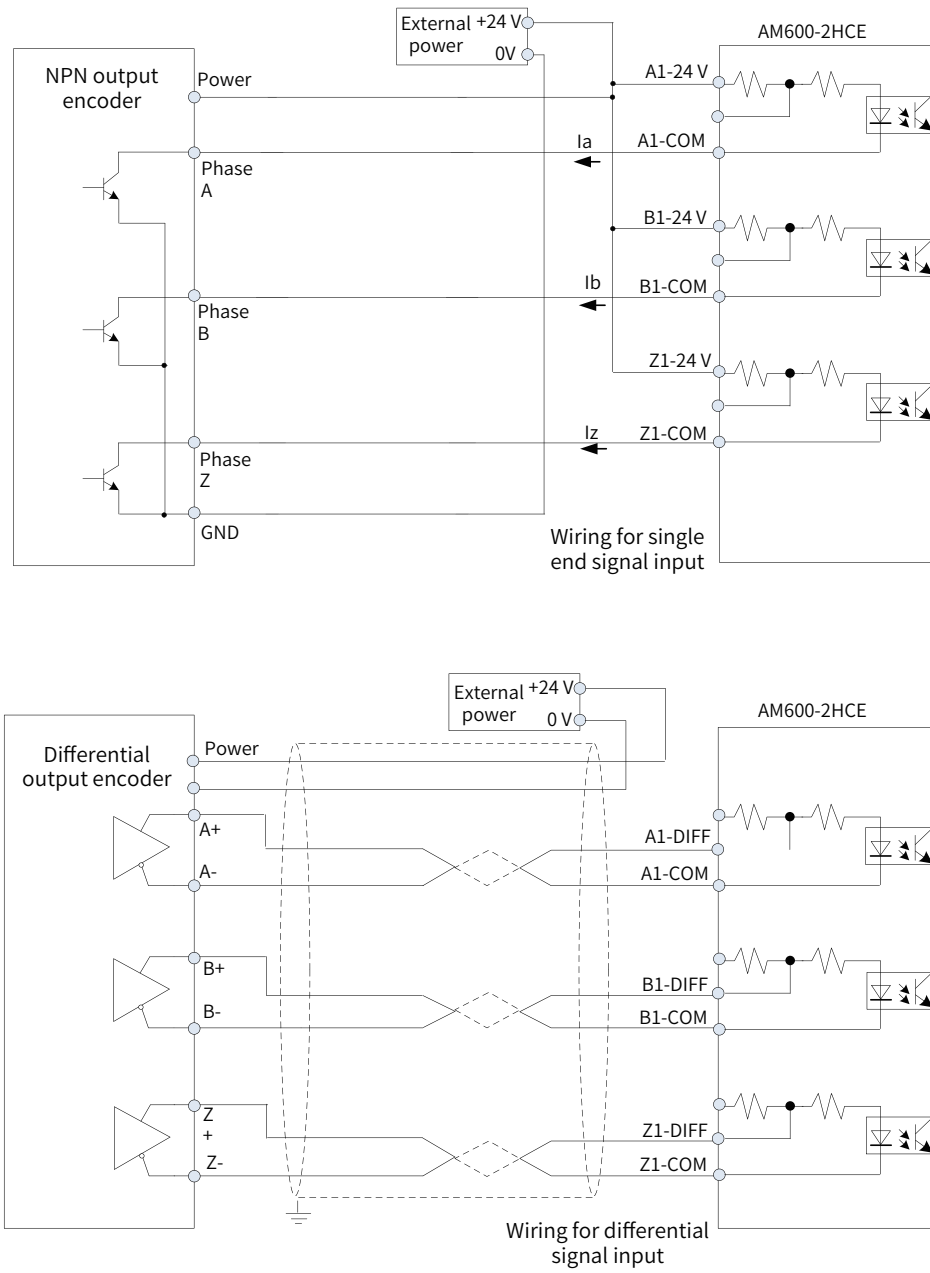

Figure 5-55 Signal connections

■ System wiring

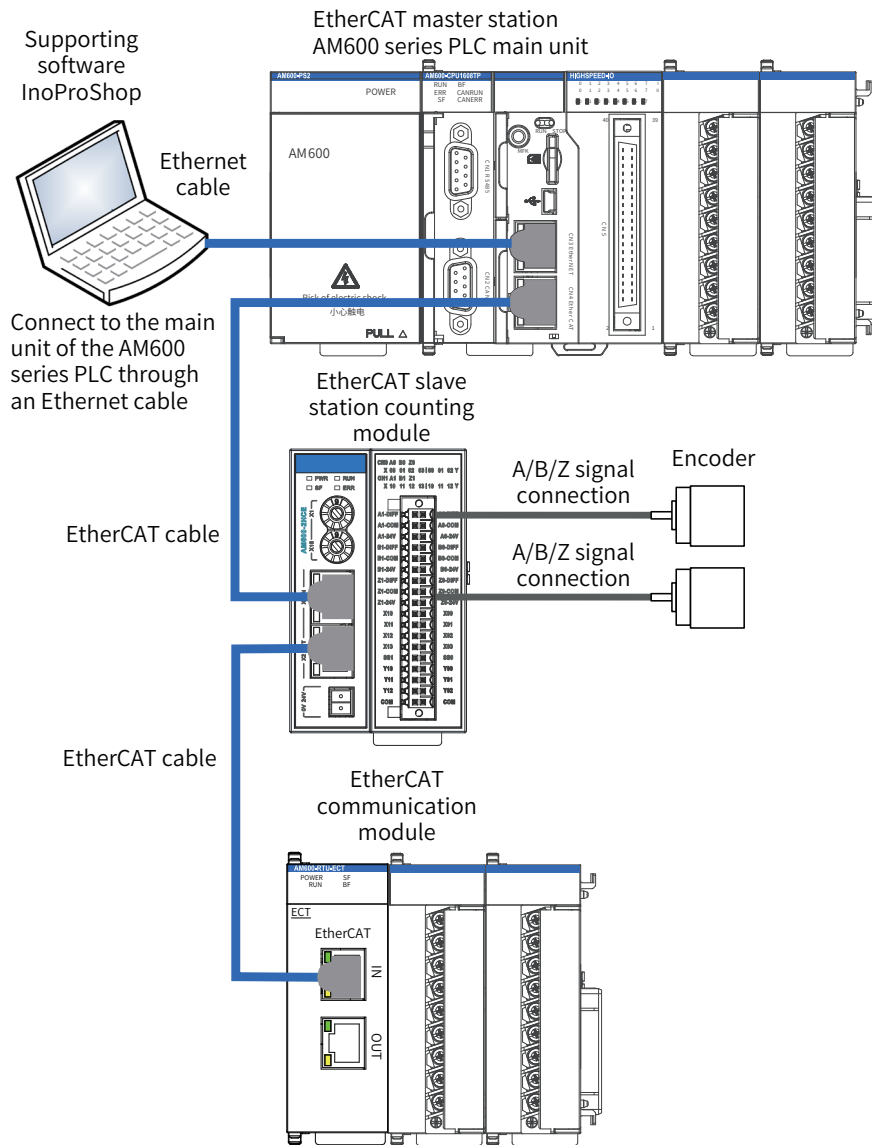

Figure 5-56 System wiring

5.7.5 Signal Wiring of the Positioning Module

1 AM600-4PME/GR10-4PME module

■ Terminal arrangement

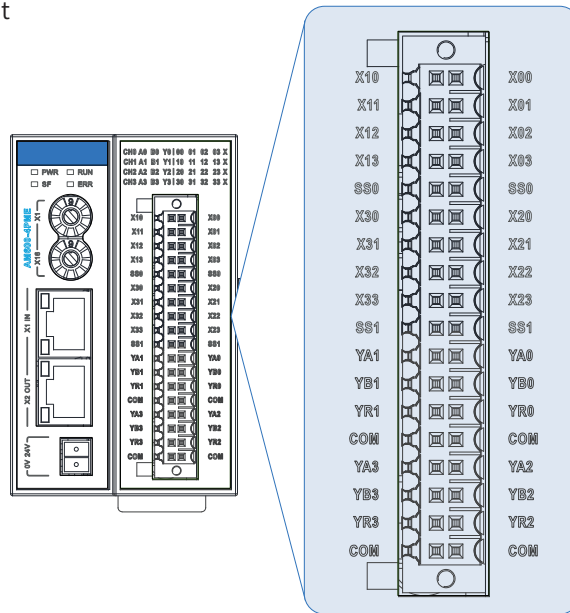
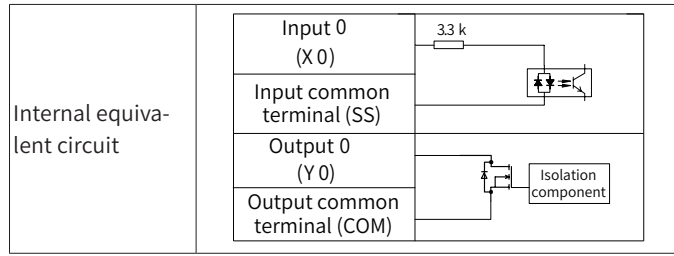

Figure 5-57 Terminal signal arrangement of the AM600-4PME

■ External wiring and internal equivalent circuit

External Wiring	Signal	Terminal No.	Signal	External Wiring
	Column B		Column A	
	CH1 input 0 (X10 positive limit)	2	1	CH0 input 0 (X00 positive limit)
	CH1 input 1 (X11 negative limit)	4	3	CH0 input 1 (X01 negative limit)
	CH1 input 2 (X12 home switch)	6	5	CH0 input 2 (X02 home switch)
	CH1 input 3 (X13 interrupted input)	8	7	CH0 input 3 (X03 interrupted input)
	CH1 input common terminal (SS0)	10	9	CH0 input common terminal (SS0)
	CH3 input 0 (X30 positive limit)	12	11	CH2 input 0 (X20 positive limit)
	CH3 input 1 (X31 negative limit)	14	13	CH2 input 1 (X21 negative limit)
	CH3 input 2 (X32 home switch)	16	15	CH2 input 2 (X22 home switch)
	CH3 input 3 (X33 interrupted input)	18	17	CH2 input 3 (X23 interrupted input)
	CH3 input common terminal (SS1)	20	19	CH2 input common terminal (SS1)
	CH1 output A (YA1)	22	21	CH0 output A (YA0)
	CH1 output B (YB1)	24	23	CH0 output B (YB0)
	CH1 output R (YR1)	26	25	CH0 output R (YR0)
	CH1 output common terminal (COM)	28	27	CH0 output common terminal (COM)
	CH3 output A (YA3)	30	29	CH2 output A (YA2)
	CH3 output B (YB3)	32	31	CH2 output B (YB2)
	CH3 output R (YR3)	34	33	CH2 output R (YR2)
	CH3 output common terminal (COM)	36	35	CH2 output common terminal (COM)



■ Signal terminal wiring

AM600-4PME

Stepping motor drive

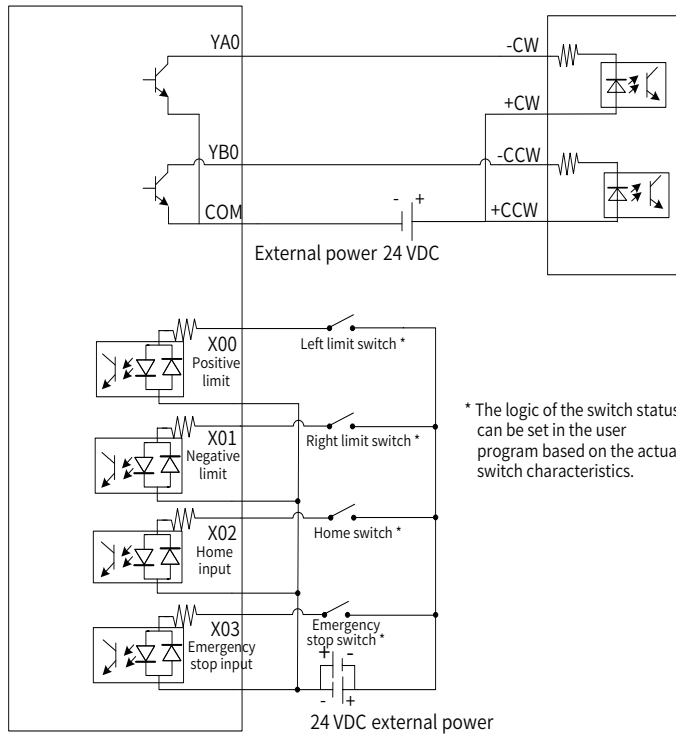

AM600-4PME

Servo motor drive

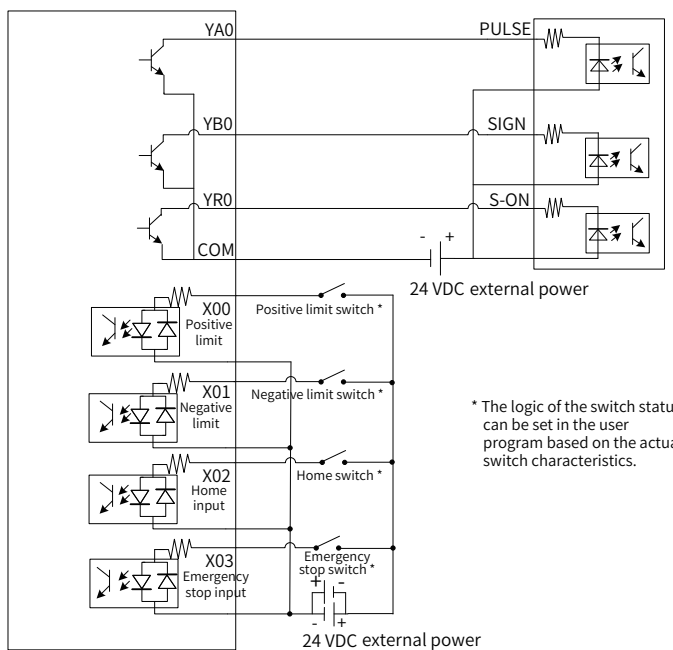

Figure 5-58 Signal terminal wiring

■ System wiring

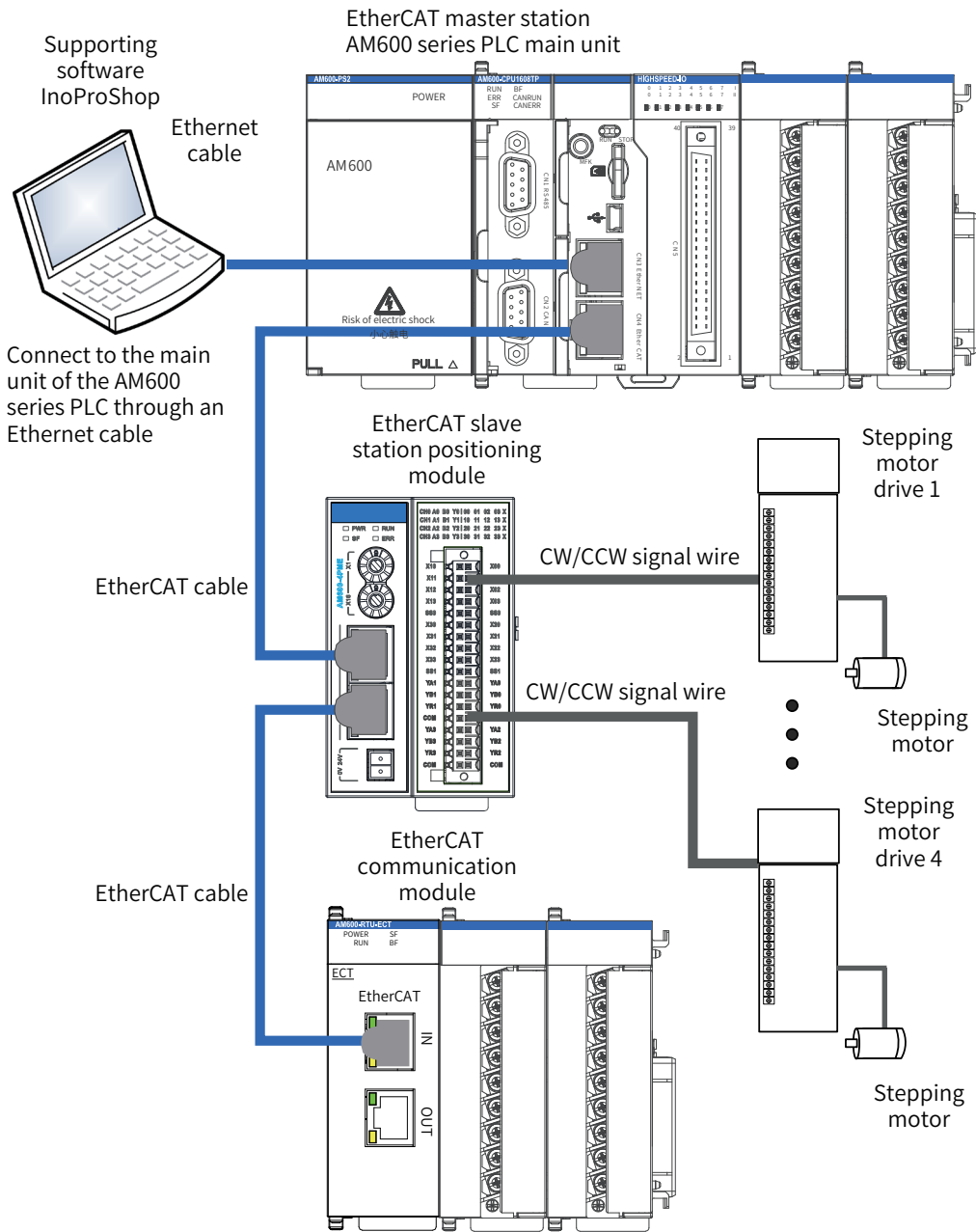

Figure 5-59 System wiring



Chapter 6 Programming Tool and Download

6.1 Getting Programming Software Tool	118
6.2 Programming Environment and Software Installation	118
6.2.1 Environment Requirements	118
6.2.2 Installation Procedure.....	118
6.2.3 InoProShop Uninstallation	121

6.1 Getting Programming Software Tool

User programming software InoProShop is free software for the Inovance AM600 series medium-sized PLC. You can obtain the installation file and references of the AM600 series products from the following paths:

- Obtain the software installation CD from Inovance distributors at all levels.
- Access www.inovance.cn/es, choose **Download**, and download the software installation package for free.

Inovance is committed to continuously improving its products and documents. Therefore, you are advised to update software versions in time and refer to the latest documents when designing your applications.

6.2 Programming Environment and Software Installation

6.2.1 Environment Requirements

Use a desktop or laptop PC that meets the following requirements:

- Operating system: Windows XP, Windows 7, Windows 8, or Windows 10
- CPU frequency: 2 GHz (recommended)
- Memory: 2 GB or larger
- Hard disk space: 5 GB of free space or larger
- Connect the PC to the AM600 PLC as follows:

Connection Mode	Cable	Remarks
Connection with a LAN network cable (recommended)	One available LAN port and one network cable on the local network	Long-distance connection between the PC and the AM600 PLC is supported, and the interaction communication is fast. For example, you can sit in the office and program the AM600 PLC in the workshop.
Connection with a USB cable	One USB cable whose AM600 end uses a Mini USB connector	-

6.2.2 Installation Procedure

1) Installation preparations

If InoProShop is installed for the first time, ensure that the available space in the destination partition is larger than 5 GB and then install it.

If you need to upgrade InoProShop, back up your work files, uninstall the original InoProShop, restart the PC, and then install the new InoProShop version.

2) Installation

Locate the directory where the installation package is stored in the Windows Explorer, and double-click the **InoProShop (V*.*.*) .exe** file (V*.*.* is the InoProShop version. Ensure that you are installing the latest version.)

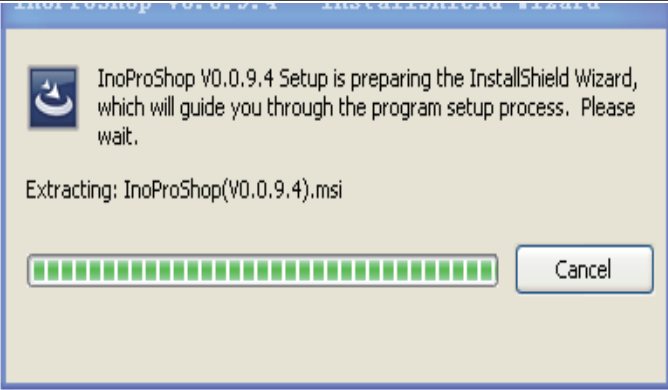
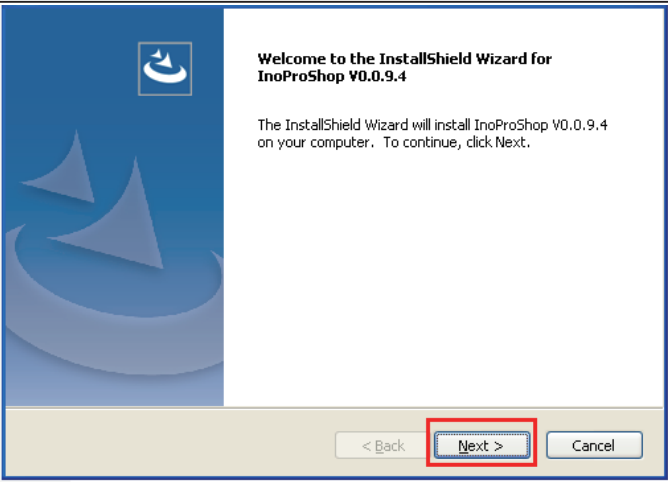
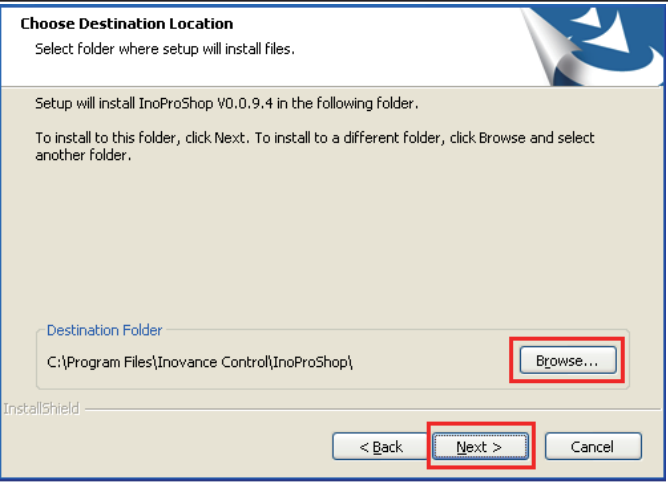
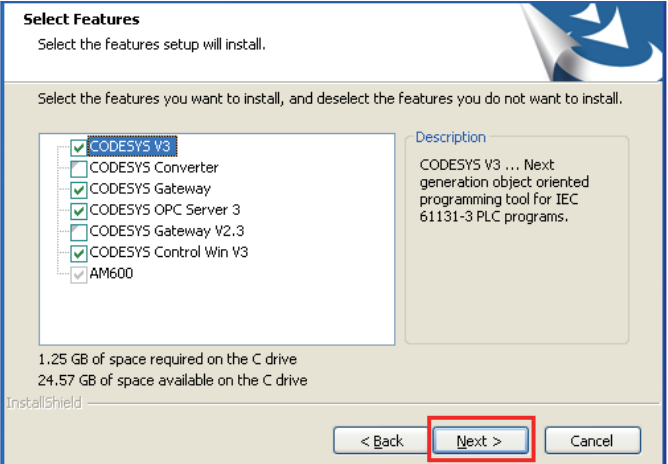
Step	Description	UI
1	Double-click the InoProShop (V**.**.*) .exe file. The preparation page is displayed.	
2	Click Next to start installation.	
3	Set the installation path and click Next .	
4	Select the features to be installed on the displayed page and click Next . Keep the default selection unless you have special requirements.	

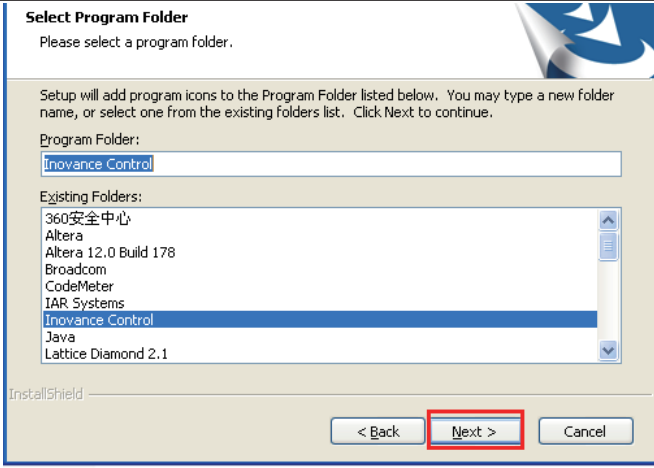
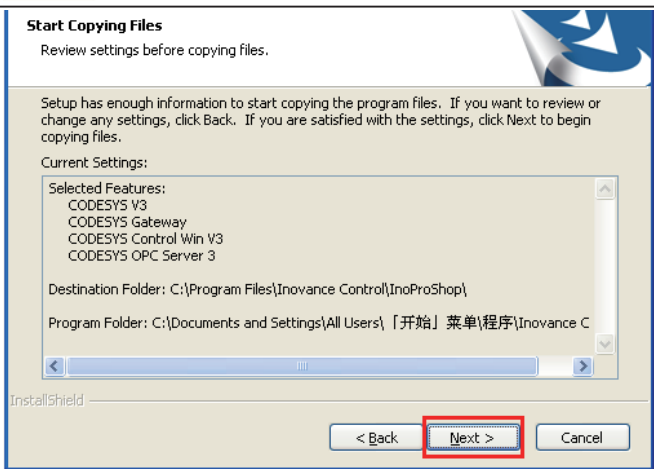
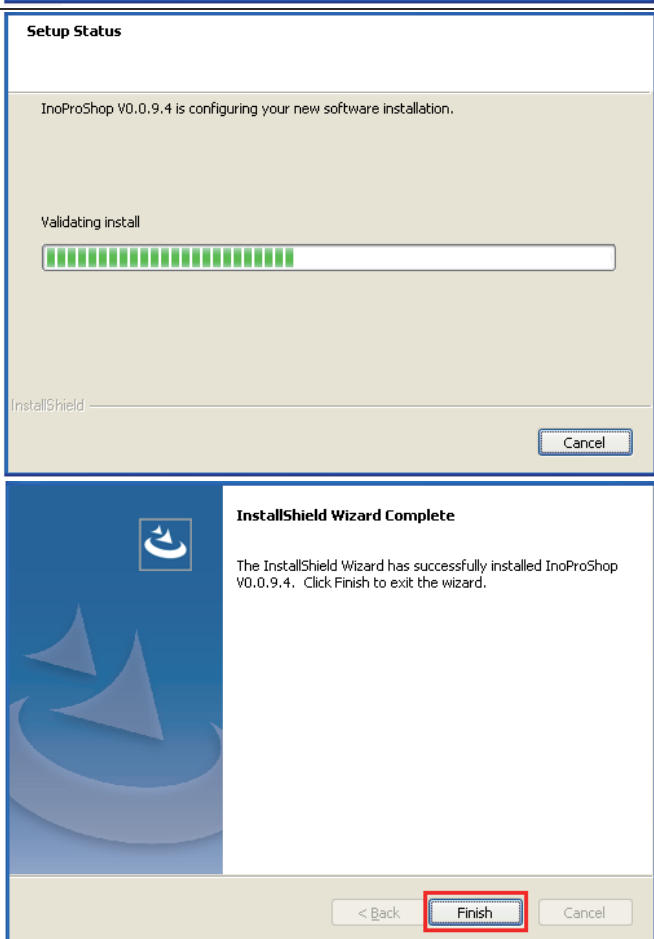
Step	Description	UI
5	Click Next .	
6	Click Next .	
7	The installation progress is displayed. Wait and click Finish when the lower window is displayed.	

3) Installation completed

InoProShop supports different languages. You can choose **Tools > Options > International Settings** on the home page and change the language.

6.2.3 InoProShop Uninstallation

Use the typical method of uninstalling software in a Window system to uninstall InoProShop. The procedure is as follows:

- Exit InoProShop and ensure that Gateway is closed. If the **CoDeSys** icon exists in the system tray of the operating system, right-click the icon and choose **Exit** to close Gateway.
- Choose **Start > Control Panel**.
- Click **Programs and Features**.
- Click **InoProShop**.
- Click **Uninstall**.



Chapter 7 Running and Maintenance

- 7.1 Running and Stop 124
- 7.2 Indicators and MFK Button 124
 - 7.2.1 LED Fault Indicators 124
 - 7.2.2 MFK Button Description 126
- 7.3 Routine Maintenance 126
 - 7.3.1 Daily Spot Check Items 126
 - 7.3.2 Periodic Spot Check 127
- 7.4 CPU Module LED Display 127
 - 7.4.1 Fault Display Mode 127
 - 7.4.2 Fault Code Display 128

7.1 Running and Stop

After the program is written into the CPU module, perform the following steps to start or stop the system.

After the program is written into the CPU module when the CPU module is in STOP state, perform the following steps to start the system:

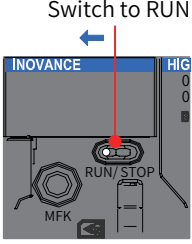
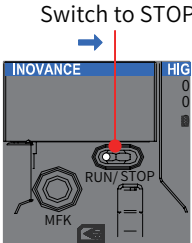
	<p>1. Set the RUN/STOP switch to RUN.</p>
	<p>2. Ensure that the RUN indicator remains on (green).</p>
	<p>3. To stop the system, set the RUN/STOP switch to STOP. You can also stop the system in the commissioning software of the host computer.</p>

7.2 Indicators and MFK Button

7.2.1 LED Fault Indicators

1) CPU module indicators

Indicator Name	Meaning				
RUN	Indicates the current running status (RUN or STOP) of the system. <table border="1" data-bbox="943 1397 1129 1464"> <tr> <td>Off</td> <td>Stop</td> </tr> <tr> <td>On</td> <td>Running</td> </tr> </table>	Off	Stop	On	Running
Off	Stop				
On	Running				
ERR	Indicates that a system fault occurs.				
SF	Indicates that a system error occurs.				
BF	Indicates that a bus error occurs.				
CANRUN	Indicates the CANopen/CANlink running status and complies with the CANopen DS303 indicator standard.				
CANERR	Indicates that a CANopen/CANlink error occurs and complies with the CANopen DS303 indicator standard.				

2) Analog I/O module indicators

Indicator Name	Meaning				
RUN	Indicates the current running status (RUN or STOP) of the system. <table border="1" data-bbox="943 1868 1129 1935"> <tr> <td>Off</td> <td>Stop</td> </tr> <tr> <td>On</td> <td>Running</td> </tr> </table>	Off	Stop	On	Running
Off	Stop				
On	Running				
ERR	Indicates that a module fault occurs.				

3) Indicators of the remote communication expansion module

■ EtherCAT slave station

LED Indicator		Meaning	Solution
Off	Off	Data is exchanged between the EtherCAT master station and the EtherCAT slave station. The preset configuration and actual configuration match.	None
Off	Blinking	No data is exchanged between the EtherCAT master station and the EtherCAT slave station.	Check the configuration and parameter settings. Check the communication address. Check whether the cable length and baud rate match. Check the terminal resistance setting.
Off	On	There is no connection between the EtherCAT master station and the EtherCAT slave station.	Check whether the bus connector is properly inserted. Check whether the bus cable to the EtherCAT master station has defects. Restart the power supply.
On	Blinking	The preset configuration is inconsistent with the actual configuration, and there is no data exchange between the master station and the slave station.	Check the EtherCAT address and slave configuration. Check if any slave module is in fault or is not properly configured.
On	Off	The communication address is not allowed.	Set a valid communication address in the range of 1 to 125.

■ CANopen slave station

LED Indicator Status	Meaning of CANRUN (Green)	Meaning of CANERR (Red)
Off	-	No error
On	The CAN bus is running normally.	The CAN bus is not connected.
Blinking	Pre-operational state	Pre-operational state
Blinking once	The CAN bus is in STOP state.	At least one error counter of the CAN controller has reached or exceeded the threshold (too many error frames).
Blinking twice	-	An error control event (node monitoring or heartbeat event) occurs.
Blinking three times	-	Communication with the synchronization object times out.

■ PROFIBUS-DP slave station

LED Indicator			Meaning	Solution
RUN (green)	SF (red)	BF (red)		
On	Off	Off	Module communication and configuration running are normal.	-
Off	Off	Off	The module has no power, or the slave station hardware is abnormal.	Check whether the the module power supply is normal. Replace the AM600-RTU-DP module.
Off	Off	On	PROFIBUS-DP communication with the master station is interrupted.	Check the communication cable connection. Check the bus configuration.
Off	Off	Blinking	Communication is interrupted due to a configuration error, parameter address error, or hardware fault.	Check the configuration and parameter settings. Check whether the address is correct. Check the hardware or cable terminal resistance.

LED Indicator			Meaning	Solution
RUN (green)	SF (red)	BF (red)		
Off	On	Blinking	The system expansion configuration is inconsistent with the actual hardware configuration.	Check whether the system configuration is consistent with the actual configuration.
Off	On	Off	The address is not allowed, a module error occurs, or a diagnostic alarm is generated.	Set a valid address in the range of 1 to 125. Replace the faulty module according to the background diagnostic information.

7.2.2 MFK Button Description

The default IP address of the CPU module is 192.168.1.88. If you cannot realize communication using another PC with a changed IP address, use the MFK button to restore the default IP address.

- 1) Hold down the MFK button in STOP state until the IP address is displayed on the LED.



- 2) If you need to restore the default IP address, press the MFK button again. Countdown starts on the LED.



- 3) To cancel the change, press the MFK button again before the countdown reaches 0. Otherwise, the IP address is reset when the countdown is complete, and the default IP address takes effect again after the PLC is powered on.

7.3 Routine Maintenance

7.3.1 Daily Spot Check Items

- Installation status and connection status

Check	Item	Check Method	Measure
<input type="checkbox"/>	Cleanliness	Check whether the machine is clean.	Clean the machine.
<input type="checkbox"/>	DIN guide rail installation	Check whether the DIN guide rail is firmly mounted to the mounting plane.	Fix the DIN guide rail.
<input type="checkbox"/>	Module installation	Check whether the modules are firmly connected to the DIN guide rail.	Ensure that the installation is secure.
<input type="checkbox"/>	Connections between modules	Check whether the locks between modules are securely fastened.	Ensure that the locks between modules are securely tightened.
<input type="checkbox"/>	Terminal screws	Check whether any terminal screw is loose.	Tighten the terminal screws.
<input type="checkbox"/>	Cables and connection terminals	Check whether the connection cables and terminals of the modules are loose.	Tighten the cables and connection terminals.

- Status indicators: Check the indicator status during the spot check. For details, see Section ["7.2 Indicators and MFK Button"](#).

7.3.2 Periodic Spot Check

The following table lists the spot checks that need to be performed once or twice every 6 or 12 months:

Check	Item	Check Method	Measure
<input type="checkbox"/>	Power supply voltage	Check whether the input AC power of the system conforms to the product specifications.	Check the power supply reliability.
<input type="checkbox"/>	Ambient temperature and humidity	Use a thermometer and hygrometer to check whether the ambient temperature and humidity conform to the product specifications.	Find out the reasons of ambient changes and take measures to ensure that the environment meets the requirements.
<input type="checkbox"/>	Air	Check whether corrosive gases exist.	Eliminate the corrosive gas source and ensure that the environment meets the requirements.
<input type="checkbox"/>	Cleanliness	Check whether the machine is clean.	Clean the machine.
<input type="checkbox"/>	Installation firmness	Check whether the DIN guide rail and modules are securely installed.	Ensure that the installation is secure.
<input type="checkbox"/>	PLC system diagnosis log	Check whether new error logs are generated.	For details about troubleshooting, see "7.4 CPU Module LED Display" .

In addition, spot checks need to be performed after device migration, renovation, and wiring.

7.4 CPU Module LED Display

7.4.1 Fault Display Mode

When a fault occurs, the fault code is displayed on the LED display of the CPU module.

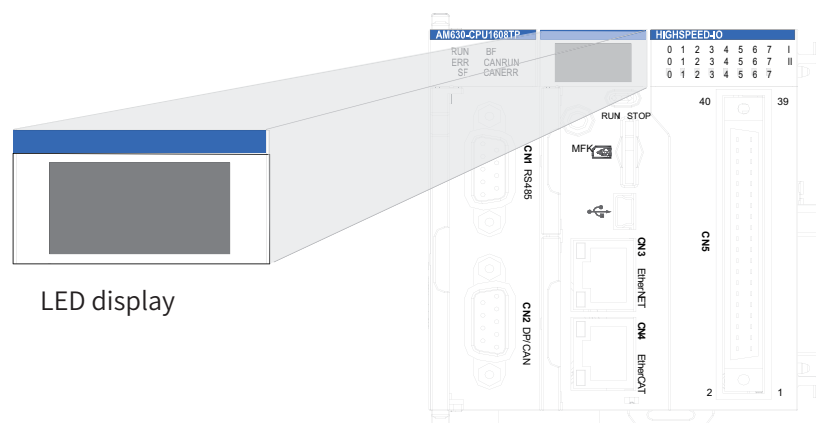

"Er" and the fault code are displayed alternately. If the fault code is 40, the LED display is as shown in the following figure:



The fault codes that the LED can display range from 00 to D4 (hexadecimal), which indicate different fault types, as listed in the following table:

Value Range (Hexadecimal)	Fault Type
00	No fault
40 to 4F	Local expansion bus diagnosis of the CPU module and I/O module diagnosis
60 to 6F	High-speed I/O diagnosis
70 to 7F	ModBusCOM0 diagnosis
80 to 8F	ModBusCOM1 diagnosis
90 to 9F	ModbusTCP diagnosis
A0 to AF	EtherCAT diagnosis (including back-end local bus diagnosis of the slave station interface module)
b0 to bF	PROFIBUS-DP diagnosis (including back-end local bus diagnosis of the slave station interface module)
c0 to cF	CANopen diagnosis (including back-end local bus diagnosis of the slave station interface module)
d0 - d4	CANlink diagnosis (including back-end local bus diagnosis of the slave station interface module)

NOTE

If the CPU module LED display keeps displaying **88**, the following problem may exist:

Symptom	Possible Cause	Solution
The CPU module LED display keeps displaying 88 .	The power supply is interrupted during firmware upgrade, and the upgrade fails.	Use the TF card to perform the complete upgrade again and ensure that the upgrade is complete.
	The user program crashes.	1. Set the RUN/STOP switch to STOP and power on the system. 2. If the fault persists, contact the manufacturer.
	Hardware fault	If the fault persists after the preceding methods are performed, the hardware of the CPU module may be faulty and needs to be replaced.

7.4.2 Fault Code Display

When a fault occurs in the system, the CPU module LED display shows the fault code. The following table describes the meanings of fault codes:

LED display of CPU module local bus and I/O module diagnosis	Meaning	Solution
00	No fault	-
40	Error of the CPU local expansion bus	Check whether the connections between modules in the local rack are normal.
41	Configuration error	Check whether the module configuration of the local rack is consistent with the background configuration.
42	Module error	Check whether modules in the local rack report faults. You can view detailed fault information on the background UI.
50	No SD card is detected when SD card is selected as the storage for power failure protection.	Check whether the SD card is normal and properly inserted.

LED display for high-speed I/O	Meaning	Solution
60	High-speed input error	Check the detailed fault information on the background UI.
61	High-speed input alarm	Check the detailed fault information on the background UI.
62	High-speed output error	Check the detailed fault information on the background UI.
63	High-speed output alarm	Check the detailed fault information on the background UI.

Modbus LED display	Meaning	Solution
70	Modbus COM0 error	Check the detailed fault information on the background UI.
80	Modbus COM1 error	Check the detailed fault information on the background UI.
90	Modbus TCP error	Check the detailed fault information on the background UI.

PROFIBUS-DP LED display	Meaning	Solution
b0	The PROFIBUS-DP slave station is not ready for data exchange.	Check whether the parameter settings of the slave station are correct.
b1	PROFIBUS-DP communication configuration error	Check whether the configuration of the PROFIBUS-DP communication module is correct.
b2	Diagnostic alarms are generated at the PROFIBUS-DP slave station.	Rectify the module fault according to the background diagnostic information. Replace the faulty module.
bE	The CPU cannot access the PROFIBUS-DP master station through the bus.	Replace the module with hardware faults.
bF	The master station cannot access the slave station through the bus.	Check the communication parameter settings. Check the communication cable connection.

CANopen LED display	Meaning	Solution
C0	Slave station error	Check whether the connections between modules in the slave station rack are normal.
C1	Hardware configuration error of the slave station	Check whether the module configuration of the slave station rack is consistent with the background configuration.
C2	Slave station module error	Check whether modules in the slave station rack report faults. You can view detailed fault information on the background UI.
CF	The CANopen master station bus is disabled.	Check whether the CANopen function is disabled at the master station and whether CANopen communication is normal at the master station.

CANlink LED display	Meaning	Solution
d0	Bus error (BUS OFF)	Check the bus connection. You can view the detailed fault information on the background UI.
d1	Address conflict	Check whether the address is correct.
d2	(Master station) No slave station is online.	Check the slave station connections and parameter settings.
d3	(Master station) The slave station is disconnected.	Check whether the slave station connections are normal.
d4	Configuration frame or command frame error	Check whether the bus configuration parameters are correct.

Appendix: Revision History

Date	Version	Revision Description
October 2018	A00	First release

Shenzhen Inovance Technology Co., Ltd.

Add.: Building E, Hongwei Industry Park, Liuxian Road, Baocheng No. 70 Zone, Bao' an District, Shenzhen

Tel: +86-755-2979 9595

Fax: +86-755-2961 9897

Service Hotline: 400-777-1260

<http://www.inovance.com>

Suzhou Inovance Technology Co., Ltd.

Add.: No. 16 Youxiang Road, Yuexi Town, Wuzhong District, Suzhou 215104, P.R. China

Tel: +86-512-6637 6666

Fax: +86-512-6285 6720

Service Hotline: 400-777-1260

<http://www.inovance.com>

2.2 Differences

2.2.1 There's no matched module of GL/GR series for AM600-RTU-DP(-INT).

AM600-RTU-DP(-INT) is a special module which was designed only for AM610 controller. Therefore a GL/GR module has not been developed to replace it, because it's not a general module.

2.2.2 GL/GR series have more modules than AM series.

Refer to the table of clause 3.2.

2.2.3 GL10-0032ETN/ GL10-3200END I/O terminals.

GL10-0032ETN/ GL10-3200END have more convenient I/O terminals (cage clamp quick connecting terminal block).



Interface of GL10-3200END



Interface of AM600-3200END

Compared with AM600-3200END/AM600-0032ETN, GL10-3200END/GL10-0032ETN have a quick (cage clamp) connecting I/O terminal blocks on the module. That means that it is not required anymore to use extension cable and conversion terminal block shown in below figure, as it was required with AM600-3200END/AM600-0032ETN modules.

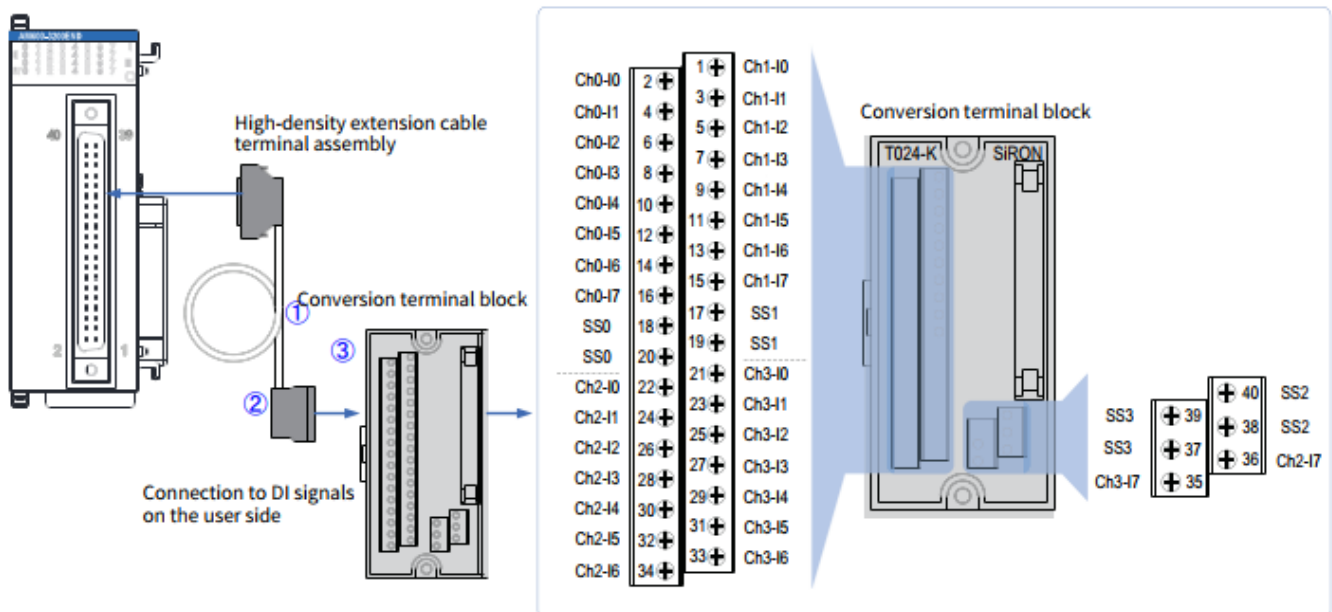

3. Modules Tables
3.1 Replaced modules table

GL/GR MODULES	DESCRIPTION	AM MODULES
LOCAL MODULES		
GL10-0016ER-INT	16-channel digital relay output module	AM600-0016ER-INT
GL10-0016ETN-INT	16-channel digital transistor NPN output module	AM600-0016ETN-INT
GL10-0016ETP-INT	16-channel digital transistor PNP output module	AM600-0016ETP-INT
GL10-0032ETN-INT	32-channel digital transistor NPN output module	AM600-0032ETN
GL10-1600END-INT	16-channel digital input module	AM600-1600END-INT
GL10-3200END-INT	32-channel digital input module	AM600-3200END
GL10-4AD-INT	4-channel analog input module	AM600-4AD-INT
GL10-4DA-INT	4-channel analog output module	AM600-4DA-INT
GL10-4PM	4-axes positioning output local module	AM600-4PM
GL10-4PT	4-channel input thermal resistance temperature detection module	AM600-4PT
GL10-4TC	4-channel input thermocouple temperature detection module	AM600-4TC
GL10-8TC	8-channel input thermocouple temperature detection module	AM600-8TC
GL10-PS2-INT	Power supply module	AM600-PS2-INT
GL10-RTU-ECTA-INT	EtherCAT (auto scan) communication module	AM600-RTU-ECTA/ AM600-RTU-ECT
GL10-RTU-COP	CANopen communication module	AM600-RTU-COP-INT
REMOTE MODULES		
GR10-0808ETNE	8 inputs and 8 outputs EtherCAT slave station module	AM600-0808ETNE
GR10-1616ETNE	16 inputs and 16 outputs EtherCAT slave station module	AM600-1616ETNE
GR10-2HCE-INT	2-channel ABZ high-speed count EtherCAT slave station module	AM600-2HCE
GR10-4PME	4-channel positioning output EtherCAT slave station module	AM600-4PME
NO MATCH		
--	--	AM600-RTU-DP-INT

3.2 New modules of GL/GR series table

GL/GR MODULES	DESCRIPTION
LOCAL MODULES	
GL10-2PH	2-channel high-speed differential pulse output functional extension module
REMOTE MODULES	
GR10-2PHE	2-channel high-speed differential pulse output EtherCAT slave station module
GR10-4ADE	4-channel analog input EtherCAT slave station module
GR10-4DAE	4-channel analog output EtherCAT slave station module
GR10-8PBE	8-channel capture probe EtherCAT slave station module
GR10-8TCE	8-channel thermocouple input EtherCAT slave station module
GR10-EC-6SW	6-channel EtherCAT branch module (1 EtherCAT input and 5 EtherCAT outputs)

4. Current status of GL/GR modules

Among all AM series extension modules and PSU, only AM600-RTU-DP(-INT) module will not be replaced by GL/GR series, which already is available in '-INT' version. The rest of AM series extension modules can be ordered now, but it will be replaced by GL/GR modules gradually.

Regarding GL/GR types, 11 modules have already the '-INT' version. Below table describes the models with '-INT' suffix. For more details about these 11 modules refer to the '0 GP PLC Models Selection Chart'.

CE certificates and English user manuals of all other GL/GR modules are expected to be completed during the first half of 2020. We will continue to pay attention to the status of GR/GL modules and apply for the '-INT' version as soon as we get the CE certificate and English user manual. Compared to standard version, '-INT' version has English documentation, English labels and the CE mark on the product. The accessories (cables) don't have '-INT' version. AM400/AM600 series CPU modules will not change item code, and already have '-INT' version.

The current status of GL/GR modules is described in below table.

GL/GR MODULES	MATERIAL CODE	EN MANUAL	CE CERTIFICATE	-INT VERSION
LOCAL MODULES				
GL10-0016ER-INT	01440193	✓	✓	✓
GL10-0016ETN-INT	01440195	✓	✓	✓
GL10-0016ETP-INT	01440199	✓	✓	✓
GL10-0032ETN-INT	01440217	✓	✓	✓
GL10-1600END-INT	01440198	✓	✓	✓
GL10-2PH	01440121	✗	✓	✗
GL10-3200END-INT	01440216	✓	✓	✓
GL10-4AD-INT	01440197	✓	✓	✓
GL10-4DA-INT	01440192	✓	✓	✓
GL10-4PM	01440129	✗	✓	✗
GL10-4PT	01440075	✓	✓	✗
GL10-4TC	01440078	✓	✓	✗
GL10-8TC	01440070	✓	✓	✗
GL10-PS2-INT	01440196	✓	✓	✓
GL10-RTU-ECTA-INT	01440194	✓	✓	✓
GL10-RTU-COP	01440083	✗	✓	✗
REMOTE MODULES				
GR10-0808ETNE	01440077	✗	✓	✗
GR10-1616ETNE	01440079	✗	✓	✗
GR10-2HCE-INT	01440206	✓	✓	✓
GR10-2PHE	01440120	✗	✓	✗
GR10-4ADE	01440058	✗	✓	✗
GR10-4DAE	01440060	✗	✓	✗
GR10-4PME	01440068	✗	✓	✗
GR10-8PBE	01440127	✗	✓	✗
GR10-8TCE	01440059	✗	✓	✗
GR10-EC-6SW	01440135	✗	✓	✗
* All modules have chinese manual				
* '-INT' version models (with '-INT' suffix in the type code) have a dedicated material code				
* Items with symbol "v" means it is done, "x" means it should be done but not yet completed				

Annex. Typical configuration for CNC machines.

In the below figures it is shown a typical configuration for CNC machine composed by:

GL10-PS2(-INT): power supply module

GL10-RTU-ECTA(-INT): EtherCAT (auto scan) communication module

GL10-3200END(-INT): 32-channel digital input module

GL10-1600END(-INT): 16-channel digital input module

GL10-0032END(-INT): 32-channel digital transistor NPN output module

GL10-4AD(-INT): 4-channel analog input module

GL10-4DA(-INT): 4-channel analog output module

